



PS4110 Storage Arrays

Hardware Owner's Manual

Version 1.0

Copyright 2011-2013 Dell Inc. All rights reserved.

Dell and EqualLogic are trademarks of Dell Inc.

All trademarks and registered trademarks mentioned herein are the property of their respective owners.

Information in this document is subject to change without notice.

Reproduction in any manner whatsoever without the written permission of Dell is strictly forbidden.

Published February 2013

Part Number: 110-6067-EN-R2

Table of Contents

1 Basic Storage Array Information	1
Notes, Cautions, and Warnings	1
Recommended Tools	1
Chassis Types	2
Array Features	2
Back-Panel Features and Indicators	5
Shutting Down and Restarting an Array	5
2 Maintaining Drives	7
About Drive Types	7
Identifying Failed Drives	7
Interpreting Drive LEDs	8
Array Behavior When a Drive Fails	9
Drive Handling Requirements	9
Drive Installation Guidelines and Restrictions	10
3 Maintaining Control Modules	17
Control Module Features	17
Replacing a Control Module	24
Replacing the MicroSD Card	29
Advanced Networking Options	31
4 Maintaining Power Supply and Cooling Modules	33
About Power Supplies	33
Identifying Power Supply Failures	33
Removing a Power Supply and Cooling Module	35
Installing a Power Supply and Cooling Module	36
5 Troubleshooting Your Array	39
Safety First—For You and Your array	39
Obtaining Technical Support and Customer Service	39
Determining Service Tag Information	40
Obtaining Component Diagnostics	40
Troubleshooting Array Startup Failure	40
Troubleshooting Loss of Communication	40
Troubleshooting Array Connections	40
Troubleshooting External Connections	41
Troubleshooting Power Supply and Cooling Modules	41
Troubleshooting Array Cooling Problems	41
Troubleshooting Control Modules	42
Troubleshooting Hard Drives	42
Index	43

1 Basic Storage Array Information

This chapter includes information about the location and basic operation of the replaceable components in a storage array, tools and equipment you will need, protecting hardware from electrostatic discharge, and power on and off operations.

Notes, Cautions, and Warnings

A **NOTE** indicates important information that helps you make better use of your system.

A **CAUTION** indicates potential damage to hardware or loss of data if instructions are not followed.

A **WARNING** indicates a potential for property damage, personal injury, or death.

Recommended Tools

You will need the following items to perform the procedures in this section:

- Bezel key
- Wrist grounding strap

Protecting Hardware

Protect a PS Series array from electrostatic discharge. When handling array hardware, make sure you use an electrostatic wrist strap or a similar form of protection. To use a wrist strap:

1. Connect the steel snap on the coil cord to the stud on the elastic band. See [Figure 1](#).

Figure 1: Using an Electrostatic Wrist Strap

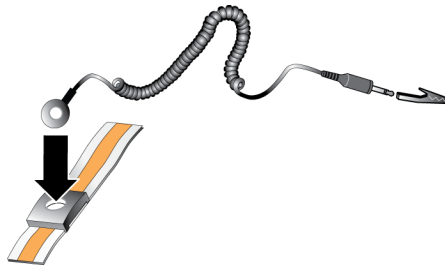

2. Fit the band closely around your wrist.
3. Connect the band to ground. You can either plug the banana connector into a matching grounded receptacle, or attach it to the matching alligator clip and connect the clip to a grounded device. Examples of an appropriate ground would be an ESD mat or the metal frame of a grounded piece of equipment.

Chassis Types

The PS4110 array is available in two different chassis types:

- A 2U chassis with 24 2.5-inch drives, installed vertically
- A 2U chassis with 12 3.5-inch drives, installed horizontally

Array Features

The array has LEDs and other features on both the front and the back.

The Bezel

The bezel is an optional trim panel that attaches to the front of the array to ensure the physical security of the array. You must remove the bezel to access and maintain the drives.

The bezel has a label that identifies the array model number.

Removing the Bezel

The steps for removing the bezel are the same for all array models.

1. Using the bezel key, unlock the bezel.
2. Holding the bezel, lift the latch on the left side of the bezel and swing the left side away from the array.
3. Lift the right side of the bezel off the right side of the array.
4. Set the bezel aside.

Installing the Bezel

The steps for installing the bezel are the same for all the array models.

1. Hook the right end of the bezel onto the right side of the chassis.
2. Swing the left end of the bezel towards the left side of the chassis.
3. Press the bezel into place until the release latch closes.
4. Using the key provided, lock the bezel and store the key in a safe place.

Figure 2: Installing the Bezel

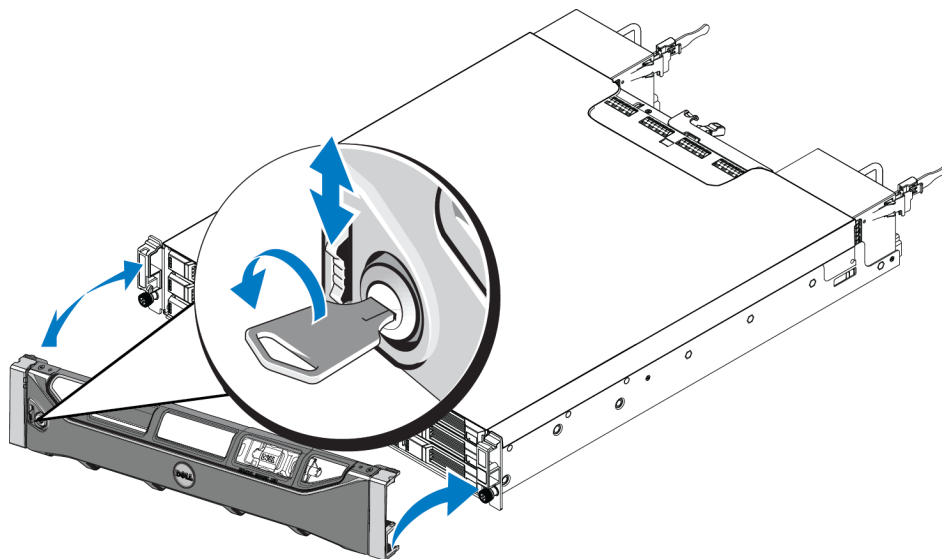

Front-Panel Features and Indicators

The front of a PS4110, without the bezel, is shown in [Figure 3](#) and [Figure 4](#).

Table 1 describes the front panel features.

Figure 3: Front Panel Features and Indicators (3.5-inch Drives)

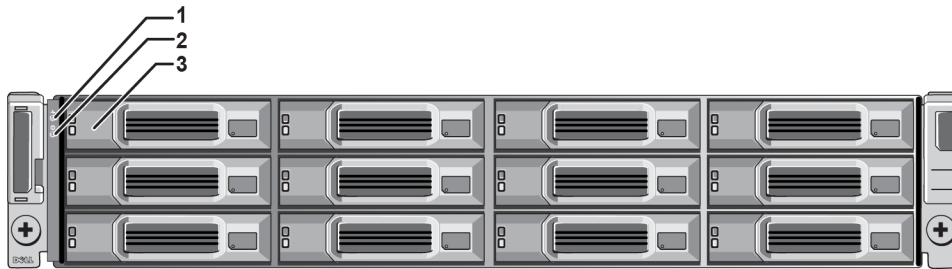

Figure 4: Front Panel Features and Indicators (2.5-inch Drives)

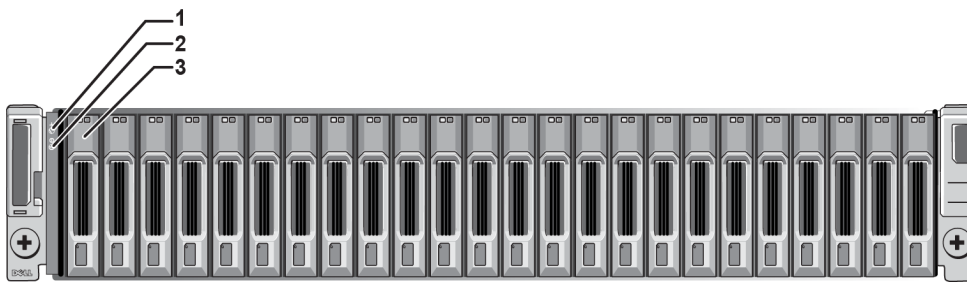

Table 1: Front Panel Feature Descriptions

Item	Indicator	Icon	Description
1	Array status LED		The array status LED lights when the array power is on. <ul style="list-style-type: none"> • Off—No power. • Steady blue—Array status is OK. • Slow blinking blue—Array status is Standby mode. • Blinking blue—Administrator request to identify the array (see the Group Manager online help). • Steady amber—Critical status. • Blinking amber—Warning.
2	Power LED		The power LED is ON when at least one power supply is supplying power to the array. <ul style="list-style-type: none"> • Off—No power, or the array is in Standby mode. • Steady green—Array has at least one power supply providing power, and array is not in Standby mode.
3	Drive Release Latch	None	Enables you to remove a drive from the array.

Note: The LEDs are part of a built-in chassis control panel that is not hot-swappable and can be replaced only by support personnel. During the array power-up sequence, these LEDs will cycle through different states until the array is fully started and the active control module has been determined.

Back-Panel Features and Indicators

The back of a PS4110 is shown in [Figure 5](#).

[Table 2](#) describes the back panel features.

Figure 5: Back Panel-Features

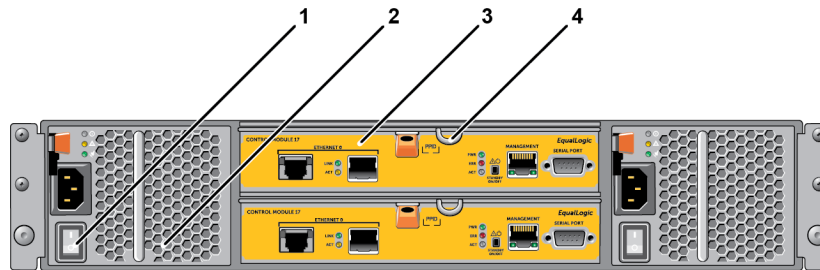

Table 2: Array Back Panel Features

Item	Feature	Identifier	Description
1	Power switch	None	The power switch controls the power supply output to the array. One on each power supply.
2	Power supply unit (PSU)	PSU0 (left) PSU1 (right)	Power supply and cooling fan module for array. For more information, see Power Supply LEDs on page 33 .
3	Control Module	CM0 (top) CM1 (bottom)	The control module provides: <ul style="list-style-type: none"> • a data path between the array and the applications using the storage • array management functions for your array
4	Control Module Release Lever	None	Enables you to remove the control module from the array.

Shutting Down and Restarting an Array

A PS Series array includes redundant, hot-swappable drives, power supplies, and control modules (in a dual control module array). You can remove a redundant component without affecting operation if a functioning component is available. Otherwise, it is recommended that you cleanly shut down the array and turn off power before removing a component.

Note: When an array is shut down, any volumes with data on the array will be set offline until the array is successfully restarted. This may affect initiators that are connected to the volumes.

1. Do one of the following:

- Use telnet or SSH to connect to a functioning IP address assigned to a network interface on the array. Do not connect to the group IP address.
- Use the null modem cable shipped with the array to connect to the serial port on the active control module (ACT LED is green) to a console or a computer running a terminal emulator.

Make sure the serial line characteristics are as follows:

- 9600 baud
 - One STOP bit
 - No parity
 - 8 data bits
 - No flow control
2. Log in to an account with read-write access, such as the `grpadmin` account.
 3. Enter the `shutdown` command, as shown next.

```
login: grpadmin
Password:
Welcome to Group Manager
Copyright 2001-2011 Dell, Inc.
group1> shutdown
```

If you are using a serial connection to shut down an array, it is safe to turn off power when the “press any key” message appears. (Pressing any key will restart both control modules.)

If you are using a network connection, the session will be disconnected before the array is fully shut down. Confirm that the ACT LED on each control module is off (not lit) before turning off power to the array.

After performing array maintenance, you can turn on power to the array. When the array restart completes, the member and volumes will be set online.

2 Maintaining Drives

You can replace a failed drive while the array remains running.

About Drive Types

Depending on your configuration, your array supports up to 24 2.5-inch SAS drives or up to 12 3.5-inch SAS drives in internal drive bays.

Drives are connected to a backplane through drive carriers and are hot-swappable.

Drives are supplied in a carrier that is keyed to fit into specific array models, and cannot be installed in other Dell arrays, or arrays not from Dell Inc.

Identifying Failed Drives

A drive failure is indicated by:

- LEDs on the drive. See [Interpreting Drive LEDs on page 8](#).
- A message on the console, in the event log, or in the Group Manager Alarms panel.
- Indications in the Group Manager Member Disks window or the CLI `member select show disks` command output.

Behind the bezel, arrays have a label showing the drive numbering for that specific array model:

- In arrays with 2.5-inch drives (installed vertically in a row), the drives are numbered 0-23, left to right.
- In arrays with 3.5-inch drives (installed horizontally), the drives are numbered from left to right and top to bottom, starting with 0 on the upper left side. [Table 3](#) shows the drive order for the 3.5-inch drives.

Table 3: 3.5-inch Drive Numbering

3.5-inch Drive Numbering			
0	1	2	3
4	5	6	7
8	9	10	11

Interpreting Drive LEDs

The LEDs on a 3.5-inch drive are shown in [Figure 6](#). The LEDs on a 2.5-inch drive are shown in [Figure 7](#). Drive LED states are described in [Table 4](#).

Figure 6: LEDs on 3.5-inch Drives

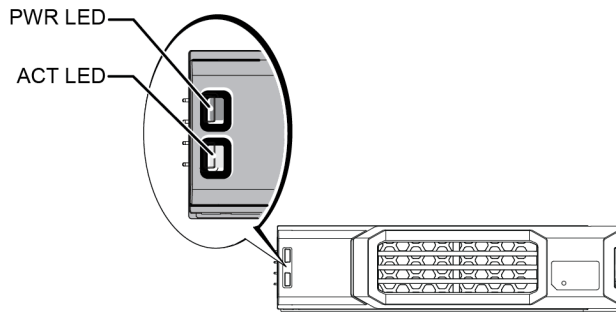

Figure 7: LEDs on 2.5-inch Drives

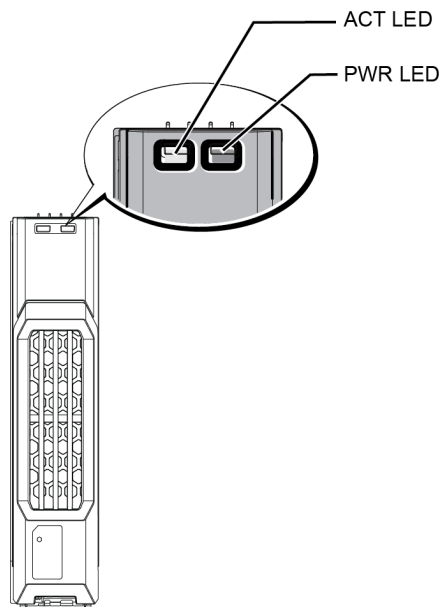

Table 4: Drive LED States

Description	Indicator States
Drive activity indicator (ACT LED)	Blinking green: Drive is busy Steady green: No drive activity
Drive status indicator (PWR LED)	Green: Drive OK Amber: Drive failed Off: No power to drive

Array Behavior When a Drive Fails

How an array handles a drive failure depends on whether a spare drive is available and whether the RAID set containing the failed drive is degraded.

For example:

- If a spare drive is available, the array automatically uses it to replace the failed drive. Performance is normal after reconstruction completes.
- If a spare drive is not available the RAID set will become degraded (except a RAID 6 set). Performance may be impaired. A RAID 6 set can survive two simultaneous drive failures.
- If a spare drive is not available and the failed drive is in a RAID set that is already degraded, data may be lost and must be recovered from a backup.
- If a drive fails, replace it. Do not re-install it in the array.

Drive Handling Requirements

Handle drives as follows:

- **Store drives properly.** Store replacement drives in the packaging in which they were shipped. Do not stack drives or place anything on top of a drive.
- **Protect drives from electrostatic discharge.** Wear an electrostatic wrist strap when handling a drive, unless it is protected from electrostatic discharge. *See "Protecting Hardware " on page 2.*
- **Handle drives carefully.** Hold a drive only by the plastic part of the carrier or the handle. Do not drop or jolt a drive or force a drive into a slot.
- **Warm replacement drives to room temperature before installation.** For example, let a drive sit overnight before installing it in an array.
- **Do not leave drive slots empty.** Each drive slot in an array must contain a drive assembly or a blank carrier. Operating an array with an empty slot will void your warranty and support contract.
- **Do not remove a functioning drive (other than a spare) from an array.** If the drive is not a spare, the RAID set may become degraded. If you remove a spare, replace the drive as soon as possible.
- **Do not remove a drive from its carrier.** This action will void your warranty and support contract.
- **Keep the shipping material.** Return a failed drive to your array support provider in the packaging in which the replacement drive was shipped. Shipping drives in unauthorized packaging may void your warranty.

Drive Installation Guidelines and Restrictions

- Replace a failed drive as soon as possible to provide the highest availability.
- Install only drives of the same type, speed, and spin rate in an array.
- Make sure the drive is oriented in the correct position for the array model. See [Front-Panel Features and Indicators on page 3](#).
- You can use drives of different capacities in the same array. However, the smallest drive in the array will determine how much space can be used on each drive. For example, if the smallest drive is 400GB, only 400GB of space will be available for use on each drive.
- Make sure to insert a drive fully in the chassis before pushing in the handle.
- When correctly installed, a drive will be flush with the front of the array. If the drive is protruding from the array, reinstall the drive.
- After installation, make sure the drive power LED is green or flashing green. See [Identifying Failed Drives on page 7](#).
- There is a two-minute delay between the time you insert a drive and the time the drive is automatically configured into a RAID set. This time interval allows multiple drives to be simultaneously configured in an array, which is more efficient than installing a single drive, configuring it, and then repeating the process. For example, when you install a drive, the timer starts. If no other drives are installed, the drive is configured after a delay of two minutes. If you install another drive before two minutes have elapsed, the timer is restarted.
- If you install a drive during RAID reconstruction or verification, the new drive will not be configured until the operation completes.

Removing a 2.5-inch Drive

1. Remove the bezel. See [Removing the Bezel on page 3](#).
2. Press the release button (callout 1 in [Figure 8](#)). The drive latch opens and the drive emerges partway from the array (callout 2).
3. Pull the drive out by the handle until it is free of the drive bay (callout 3).

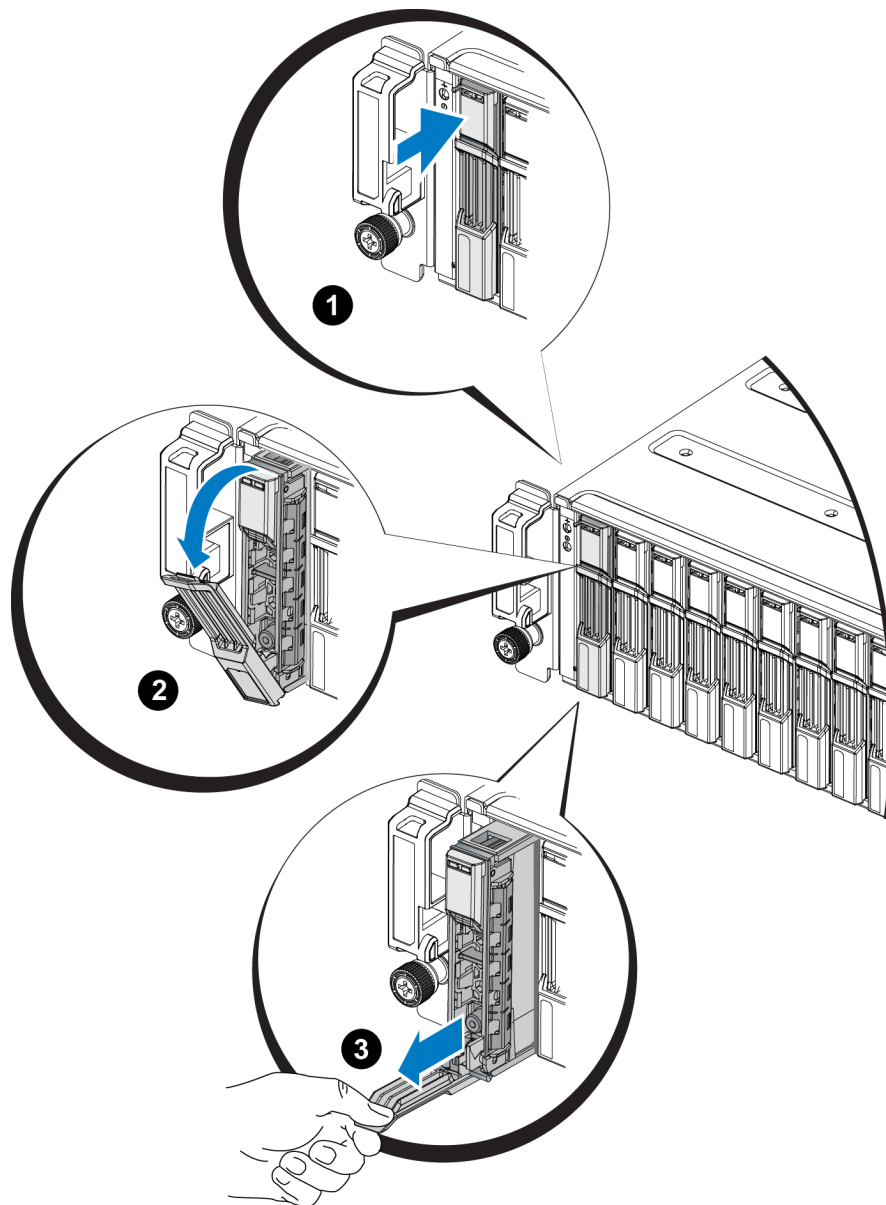
Figure 8: Removing a 2.5-Inch Drive

Installing a 2.5-inch Drive

The 2.5-inch drives are installed vertically, with the drive release latch on the top and the drive label on the bottom.

1. Wear electrostatic protection when handling a drive. *See "Protecting Hardware " on page 2.*
2. Open the drive release latch.
3. Hold the drive by the carrier and slide the drive most of the way into a slot (callout 1 in [Figure 9](#)).

4. Push the drive completely into the slot (callout 2). The drive handle will begin to close onto the drive (callout 3).
5. Push in the handle until you hear a click (callout 4).

Figure 9: Installing a 2.5-inch Drive

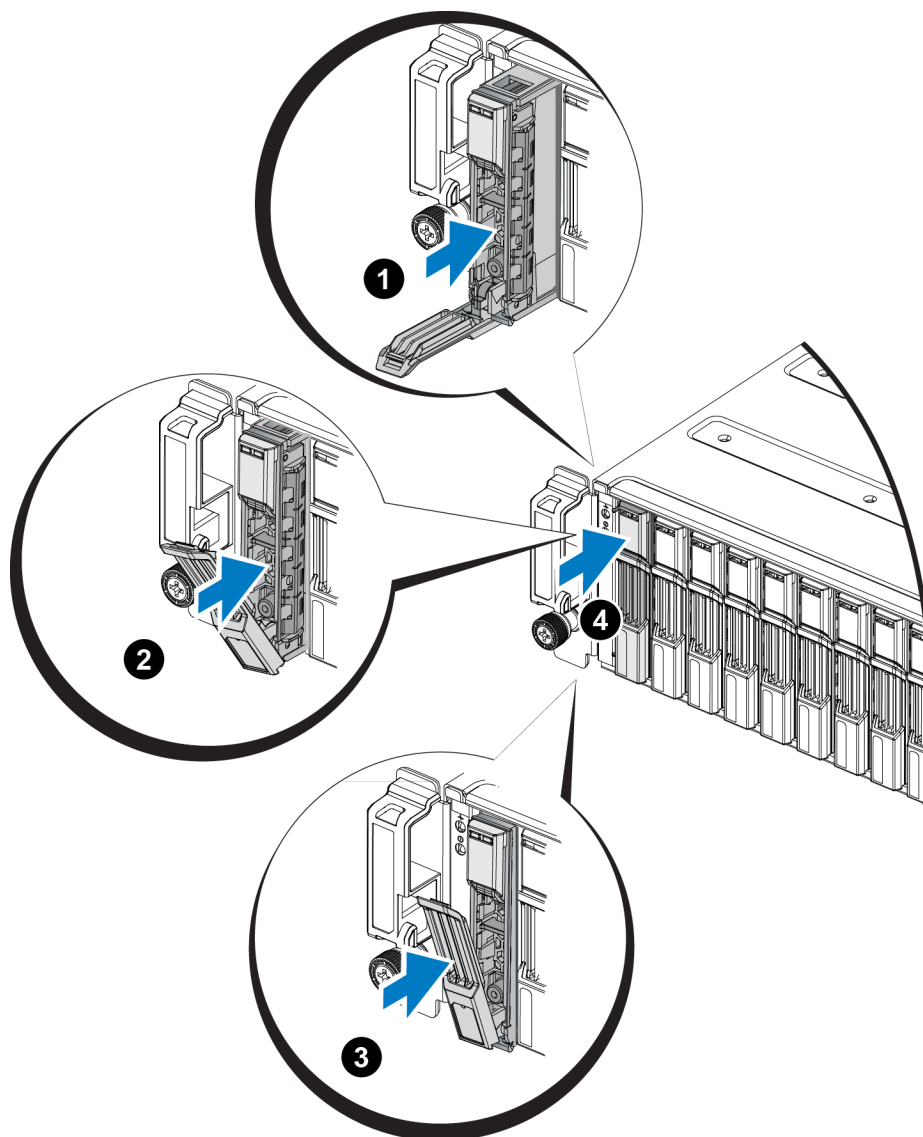

Verify that the new drive is operational by examining the LEDs on the front panel, as described in [Interpreting Drive LEDs on page 8](#). In addition, examine the GUI Member Disks window and the CLI `member select show disks` command output.

Removing a 3.5-inch Drive

1. Remove the bezel. See [Removing the Bezel on page 3](#).

2. Press the release button (callout 1 in [Figure 10](#)). The drive latch opens and the drive emerges partway from the array (callout 2).
3. Pull the drive out by the handle until it is free of the drive bay (callout 3).

Figure 10: Removing a 3.5-Inch Drive

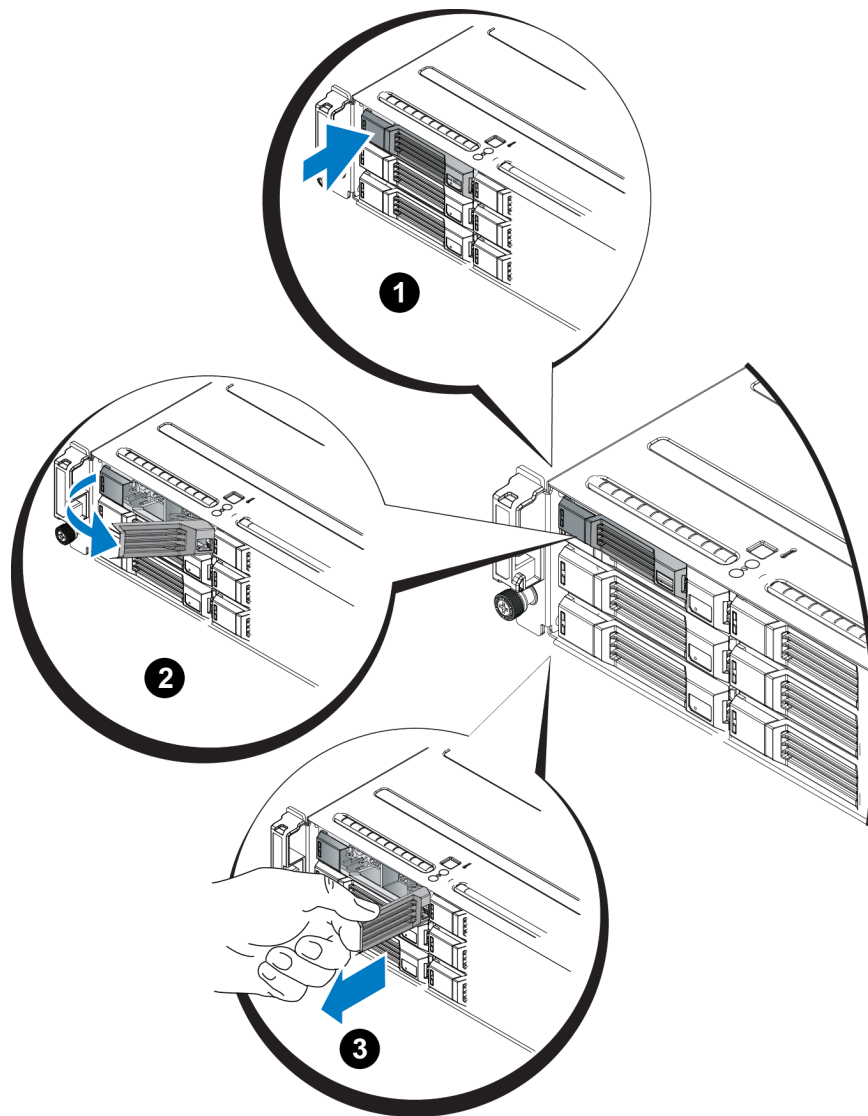

Installing a 3.5-inch Drive

The 3.5-inch drives are installed horizontally, with the drive release latch to the left and the drive label to the right.

1. Wear electrostatic protection when handling a drive. *See "Protecting Hardware " on page 2.*
2. Open the drive release latch.

3. Hold the drive by the carrier and slide the drive most of the way into a slot (callout 1 in [Figure 11](#)).
4. Push the drive completely into the slot (callout 2). The drive handle will begin to close onto the drive (callout 3).
5. Push in the handle until you hear a click (callout 4).

Figure 11: Installing a 3.5-inch Drive

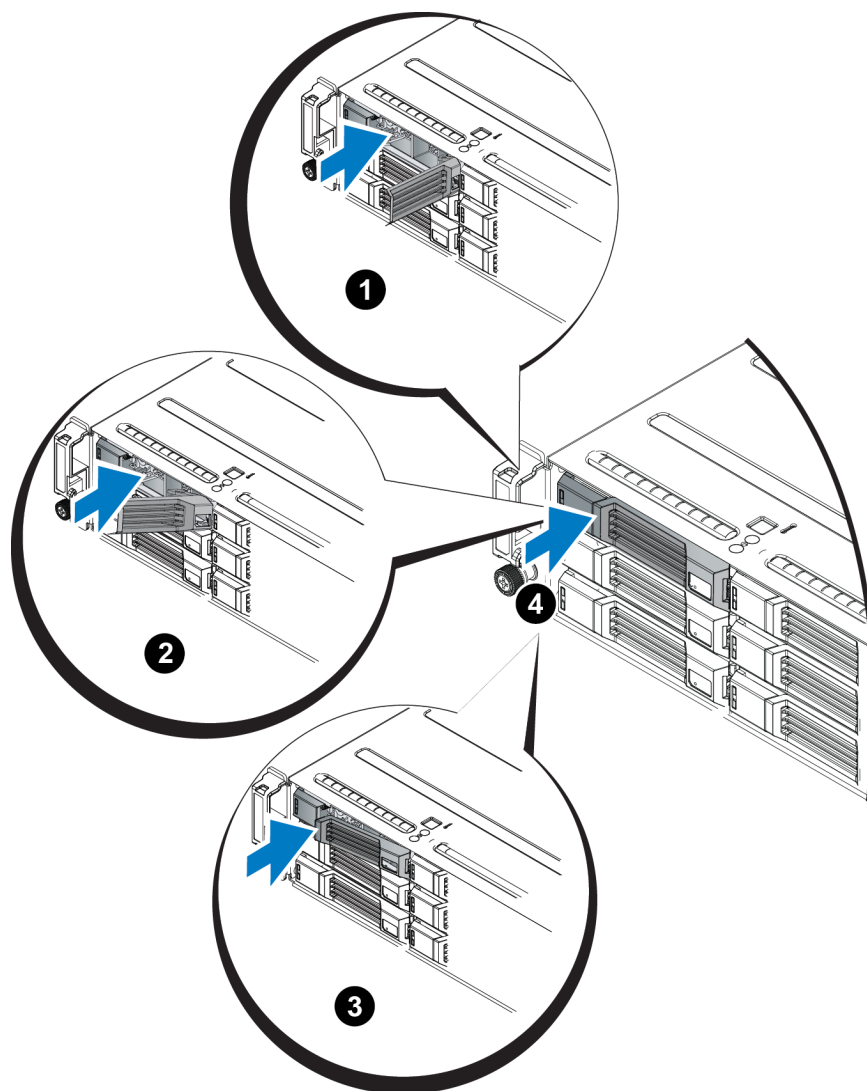

Verify that the new drive is operational by examining the LEDs on the front panel, as described in [Interpreting Drive LEDs on page 8](#). In addition, examine the GUI Member Disks window and the CLI `member select show disks` command output.

Removing a Drive Blank

Warning: To maintain proper system cooling, all empty drive bays must have drive blanks installed.

1. Remove the bezel. See [Removing the Bezel on page 3](#).
2. Press the release tab and slide the drive blank out until it is free of the drive bay. See [Figure 12](#) or [Figure 13](#).

Figure 12: Removing and Installing a 3.5-Inch Hard-Drive Blank

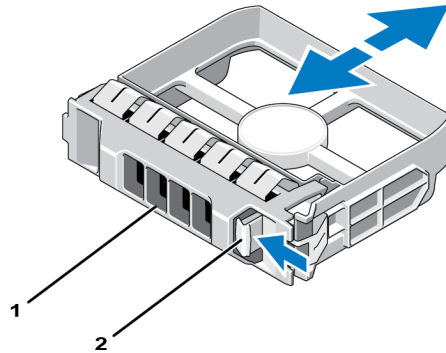
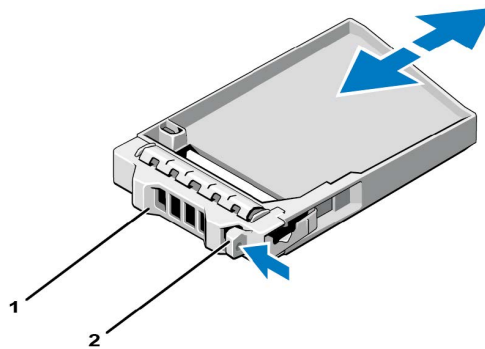

Figure 13: Removing and Installing a 2.5-Inch Hard-Drive Blank



Item	Description
1	Drive blank
2	Release tab

Installing a Drive Blank

1. Remove the bezel. See [Removing the Bezel on page 3](#).
2. Insert the drive blank into the drive bay until the blank is fully seated.
3. Attach the bezel.

3 Maintaining Control Modules

Different PS Series array models contain different control module types. The combination of chassis type, control module pair, and drives determines the PS Series array model number.

The control modules in a PS Series array contain the PS Series firmware which provides the Group Manager GUI, the command line interface, and all the array and storage management functions and features.

Ideally, an array has two control modules (which must be of the same type) to avoid a single point of failure for the array.

A PS4110 array includes one or two hot-swappable Type 17 control modules.

One functioning control module is required for array operation. You access control modules from the rear of the array.

Control Module Features

The Type 17 control module includes:

- Two 10G Ethernet ports, both labeled Ethernet 0. Each port has its own LEDs indicating status and activity:
 - One 10GBASE-T port
 - One SFP+ port

Note: Only one 10G Ethernet port can be used at a time. If both ports are attached to an active switch, the control module will prefer to communicate over the SFP+ interface.
- One 10Mb/100Mbps port, labeled MANAGEMENT - for use only if you configure a management network. The management port has two LEDs to indicate status and activity. *See "Configuring the Management Port" on page 31* for more information.
- A column of LEDs labeled PWR (power), ERR (error condition) and ACT (activity) that indicate the status of the control module.
- A recessed button labeled STANDBY ON/OFF that allows you to quickly shut down the array in certain circumstances. *See About the Standby On/Off Button on page 22* for more information.
- One serial port (for use if there is no network access to the array).
- A field-replaceable microSD card containing the PS Series firmware. The microSD card is accessed from the rear of the control module.

- A release button and latch to release the control module from the array for replacement. The release lever has a switch that detects activation and prompts the array to save data to non-volatile storage, thereby protecting your data.

Caution: Do *not* mix control module types in an array. Always make sure both control modules are the same type and color. See the latest PS Series *Release Notes* for information about other supported control modules.

About Control Module Configurations

While an array can run using only one control module, it is not recommended as this creates a single point of failure. If the control module fails and there is no other to take over, all access to your volumes stops until you replace it.

Only one control module is active (serving network traffic) at one time. The secondary (redundant) control module mirrors cache data from the active control module. If the active control module fails, the secondary will take over network operations.

Single Controller Configuration

A single control module is a single point of failure. If the control module fails, the entire array (and all the volumes on it) becomes unavailable. Dell strongly recommends buying an array with two control modules, or installing a second control module in a single-controller array.

In an array with a single control module, the module must be in slot CM0.

Caution: For proper array cooling and airflow requirements, there must be a blank filler in the empty control module slot.

Dual Controller Configuration

A dual control module configuration eliminates a single point of failure in the array. If the active control module fails, the secondary control module takes over immediately with no interruption of service. This gives you time to replace the failed control module while your volumes and data remain accessible.

In addition, a dual control module configuration supports a feature called vertical failover. An Ethernet port on the active control module can fail over to the same Ethernet port on the secondary control module if a network path fails. For example, if Ethernet 0 on CM0 loses connectivity (switch 0 fails), Ethernet 0 on CM1 takes over.

[Figure 14](#) illustrates the recommended configuration to support vertical failover.

Figure 14: Recommended Network Configuration to Support Vertical Failover

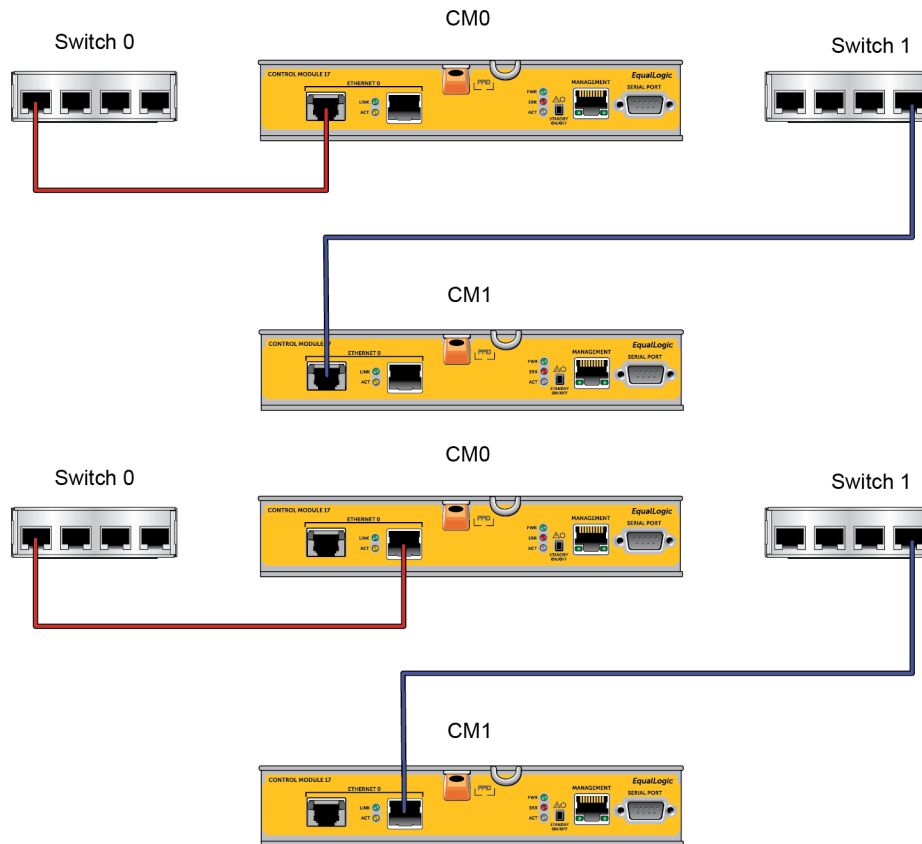

Note: If a network port is available for failover on either control module, but is not currently in use, its LEDs will not be lit.

Interpreting Control Module LEDs

Control modules have the following LEDs:

- The Ethernet ports and the Management port each have LEDs that indicate the port's status and activity.
- Below the release latch is a column of three LEDs that indicate the status of the entire control module.

Figure 15: Control Module LEDs

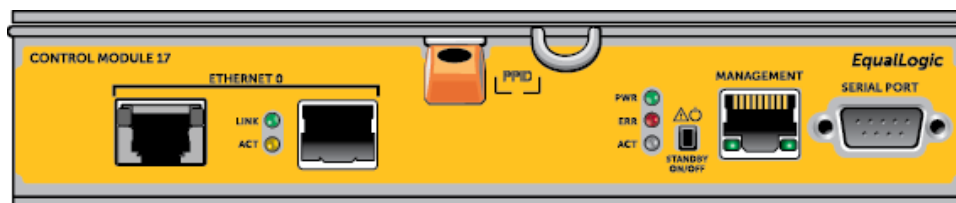

Table 5: Ethernet and Management Port LED Descriptions

10GBASE-T Ethernet LED Location	State	Description
Left (Link)	Off	No power, not connected to network, or passive.
	On	Connected to network.
Right (Act)	Off	No power, not transmitting, or not receiving.
	On	Transmitting or receiving.
SPF+ Ethernet LED Location	State	Description
Top (Link)	Off	No power, not connected to network, or passive.
	On	Connected to network.
Bottom (Act)	Off	No power, not transmitting, or not receiving.
	On	Transmitting or receiving.
Management LED Location	State	Description
Left (Link)	Off	No power or not connected to network.
	On	Connected to network.
Right (Act)	Off	No power, not transmitting, or not receiving.
	On	Transmitting or receiving.

Table 6: Control Module Status LED Descriptions

LED Name	State	Description
PWR	Off	No power.
	On (steady green)	Power/OK.
ACT	Off	No power, secondary control module is not synchronized with active control module, or error condition.
	Steady green	Active control module (serving network I/O).
	Steady amber	Secondary control module. Cache is synchronized with active control module.
ERR	Off	Normal operation or no power.
	Steady red	Array is starting up, in error condition, or in Standby mode.
	Blinking red	Array is entering power standby mode because the Standby On/Off button was pressed.

Identifying Control Module Failures

You can identify a failure in a control module by:

- **LEDs** on the control module itself. See [Interpreting Control Module LEDs on page 19](#).
- **Messages** on the console, in the event log, or in the Group Manager GUI Alarms panel.

- **Group Manager GUI and CLI output.** The Member Controllers window or the `member select show controllers` command output shows the control module status `not installed`.

When viewed from the rear of the array, CM0 is on the top, and CM1 is on the bottom. See [Front-Panel Features and Indicators on page 3](#).

If a control module fails, contact your PS Series support provider for a replacement.

Understanding Failover Behavior

In a dual control module array, only one control module is active (serving network traffic) at one time. Each control module includes a cache-to-flash module for storing recently-used data.

For redundancy, the cache on the secondary control module mirrors the data that is stored in the cache on the active control module.

The active control module can use a network interface on the secondary control module if there is a cable connected from the corresponding port on the secondary control module to a network switch.

Note: The management ports on the control modules do not fail over if one control module fails. Therefore, if you are using a dedicated management network, make sure the management ports on both control modules are connected to the management network.

A PS Series array provides the following types of network failure protection:

- **Vertical failover.** In a dual control module array, a network port on the active control module can fail over to the same network port on the other (secondary) control module if a network path fails. For example, if Ethernet 0 on CM0 loses connectivity (switch 0 fails), Ethernet 0 on CM1 takes over. See ["Dual Controller Configuration" on page 18](#) for details.
- **Control module failover.** In a dual control module array, if the active control module fails, the secondary control module automatically takes over and becomes active.

If a cable is connected to a network port on the newly-active control module, network I/O can switch to its network interface. Depending upon circumstances, network I/O may instead continue through the previously active control module. (i.e. The control module that becomes active can use either its own local network interface, or the network interface on the previously-active control module.)

Control module failover is transparent to applications, but iSCSI initiators must reconnect to the group IP address.

Maintaining Control Module Firmware

A control module has a microSD card running the array firmware. You should run the latest firmware version to take advantage of new product features and enhancements.

Caution: In a dual control module array, both control modules must be running the same firmware version; otherwise, only one control module will be functional. When you update the array firmware, both control modules are updated to the same firmware version.

Group members should run the same firmware version; otherwise, only the functionality common to all versions will be available in the group. See the PS Series *Release Notes* for information about mixed-firmware groups.

If you are adding a second control module, upgrading a control module, or replacing a failed microSD card, contact your PS Series support provider for a replacement. Inform your provider of the current PS Series firmware version on your system. If you are replacing a failed control module, remove the microSD card from the failed control module and install it in the replacement control module. This will make sure that you keep the correct firmware.

To display the firmware version running on an array, examine the GUI Member Controllers window or use the following CLI command:

```
member select show controllers
```

If the firmware on a microSD card does not match the firmware running on an array, do not install it. Instead, contact your array support provider.

Control Module Handling Requirements

Follow these control module handling requirements:

- **Do not remove an active control module.**
- **Protect control modules from electrostatic discharge.** Always wear an electrostatic wrist strap when handling a control module. *See "Protecting Hardware " on page 2.*
- **Do not remove a control module from an array while the control modules are synchronizing.** When synchronization completes, a console message will appear. Also, the ACT LED on the secondary control module will be orange.
- **Do not leave a control module slot empty.** In an array with one control module, always attach a blank face plate to the empty control module slot.
- **Store control modules properly.** Store a control module in its original packaging or in an anti-static bag or place the control module on a surface protected from electrostatic discharge.

About the Standby On/Off Button

The Type 17 control module has a small, recessed button labeled Standby ON/OFF (see [Figure 16](#)). The button is recessed to prevent accidental activation.

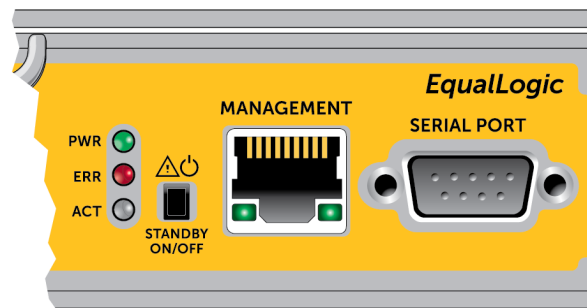
Figure 16: Standby Button Location

Enabling the Standby Feature

To use the standby button, a group administrator must enable the feature in the Group Manager GUI or CLI.

Enabling the use of the button applies group-wide; that is, it allows you to press the button to shut down any member (array) that has the button (currently PS4100, PS4110, PS6100, and PS6110 array models only). You do not need to enable use of the button on each member separately.

Note: Only a user with group administrator privileges can enable the standby feature on the group. However, anyone can press the button, and the group cannot determine who put the array into standby on/off mode. Therefore, group administrators should consider their environment's security concerns before enabling this feature.

Using the Standby Button

After the feature is enabled group-wide, you can use the Standby On/Off button on either control module of any applicable member to shut down the array quickly without using the Group Manager GUI or CLI.

You must press in and hold the Standby On/Off button for at least two (2) seconds to shut down the member to the standby state.

(To fully shut down the array, turn off the switches on the power supply and cooling modules.)

To turn the member back on, press and hold the Standby On/Off button again (if the power supply switches are turned on).

Important Considerations

Use this button only in when you must shut down a member fast, in situations where you do not have access to the Group Manager GUI or CLI.

Caution: In standby mode, any volumes that use space on that member or that are bound to that member become unavailable!

All operations on the member are suspended, there is no I/O activity to or from the member, and the member's firmware is not running.

Use the Standby On/Off button only when you need to quickly shut down an array and you may not have access to the GUI or CLI; for example, if you discover a problem in your lab environment, such as high temperature or a water leak that may damage the array, that requires you to shut down the array as soon as possible.

Caution: Do not shut down the array (with the standby on/off button or by any other method) before replacing a failed control module! If the member is shut down and a control module is removed, the array automatically returns to full-power mode.

Using the Standby On/Off button on one member does not affect any other group members. You must press the button on each member that has it. Group members that do not have the button remain online; to shut them down, you must use the GUI or CLI.

Replacing a Control Module

If a control module fails, remove it and replace it with a functioning control module, as described in this section.

You will also need to temporarily remove a control module when you want to replace its microSD card. Refer to [Replacing the MicroSD Card on page 29](#) for information about replacing the MicroSD card.

You can partially or completely remove a control module without shutting down the array if the remaining control module has at least one connected and functioning network interface. The procedures for doing this type of control module replacement are described in [Control Module Replacement Procedures on page 25](#).

When you remove a control module, wear an electrostatic wrist strap, as described in [Protecting Hardware on page 2](#), and be sure to place it on a surface that is protected from electrostatic discharge.

Caution:

- Do not remove an active control module.
- Do not remove a control module from an array while the control modules are synchronizing. A message will appear on the console when synchronization completes. The ACT LED on the secondary control module will be orange when synchronization completes.
- For proper cooling, do not leave a control module slot empty. If an array will operate for a long time with only one control module, you must install a blank in the empty slot. You can order a control module blank from your PS Series array service provider.
- Do not remove a failed control module until you are ready to replace it.

Control Module Replacement Procedures

This section describes the procedures for removing and replacing one or both control modules in your PS Series array. The following replacement scenarios are covered:

- Replacing the secondary control module in an array.
- Replacing the active control module in an array.
- Replacing both control modules in an array.

Replacing the Secondary Control Module

Use the following procedure to replace the secondary control module in the array:

1. Remove the control module from the array. (As described in [Removing a Control Module on page 26.](#))
2. Remove the SD card from the control module. (As described in [Removing the MicroSD Card on page 29.](#))
3. Install the SD card in the replacement control module. (As described in [Inserting the MicroSD Card on page 30.](#))
4. Insert the replacement control module into the array. (As described in [Installing a Control Module on page 27.](#))

Replacing the Active Control Module

Use one of following procedures to replace the active control module in the array:

- **One Controller Array:**
 1. Shut down the system with a full shutdown. (As described in [Shutting Down and Restarting an Array on page 5.](#))
 2. Replace the control module. (As described in [Replacing the Secondary Control Module on page 25.](#))
- **Two Controller Array:**
 1. Use the “restart” command to make the active control module secondary.
 2. Replace the control module that is now secondary (was active before the restart). (As described in [Replacing the Secondary Control Module on page 25.](#))
- **Two Controller Array - One Controller Defective:**
 1. Replace the defective control module first, so the array has two good control modules.
 2. Use the “restart” command to make the active control module secondary.

3. Replace the control module that is now secondary (was active before the restart). (As described in [Replacing the Secondary Control Module on page 25.](#))

Replacing Both Control Modules

Use the following procedure to replace both control modules in the array:

1. Replace the secondary control module first. (As described in [Replacing the Secondary Control Module on page 25.](#))
2. Use the “restart” command to make the active control module secondary.
3. Replace the control module that is now secondary (was active before the restart). (As described in [Replacing the Secondary Control Module on page 25.](#))

Removing a Control Module

Before removing a control module:

- Review the information at the beginning of [Replacing a Control Module on page 24.](#)
- Attach an electrostatic wrist strap. [See "Protecting Hardware " on page 2.](#)
- Disconnect any serial or network cables attached to the control module. If there are open interface connectors on the other control module, re-attach the network cables to the other control module to provide uninterrupted data access.

Caution: Do not remove an active control module.

To remove a control module:

1. Push down on the orange release button (callout 1).
2. While holding the orange button (callout 1) down, swing the black release latch (callout 2) towards you. This starts to eject the control module from the array. Remove the control module.

The following illustration provides an example of control module removal.

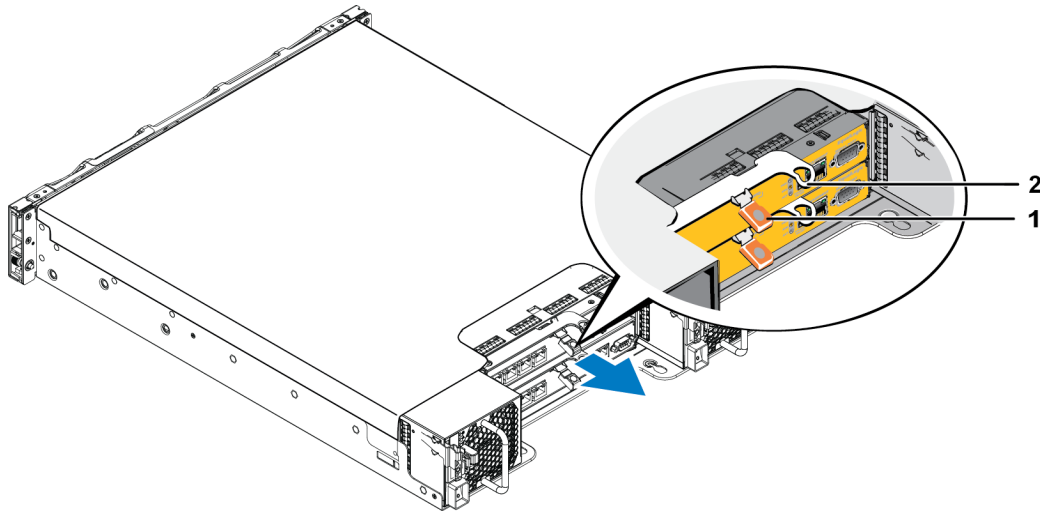
Figure 17: Removing a Control Module (2U Array)

3. Place the control module on a flat surface where it will be protected from electrostatic charge. To avoid damage, do not place anything on top of the control module.
4. If you are replacing a failed control module, remove the microSD card from the failed control module and install it in the replacement control module. This will make sure that the new control module is running the correct firmware. See [Replacing the microSD Card on page 29](#).

Caution: Do not operate an array with an empty control module slot.

Return the failed control module in the packaging in which the replacement module was shipped. Contact your PS Series support provider for information about returning hardware.

Installing a Control Module

You can install a control module without shutting down the array.

Caution: Do not mix control module types in an array.

Control modules are installed horizontally in the array, with the Ethernet ports on the left and the serial port on the right.

Facing the rear of the array, the upper control module is CM0 and the lower control module is CM1, as shown in the following illustration.

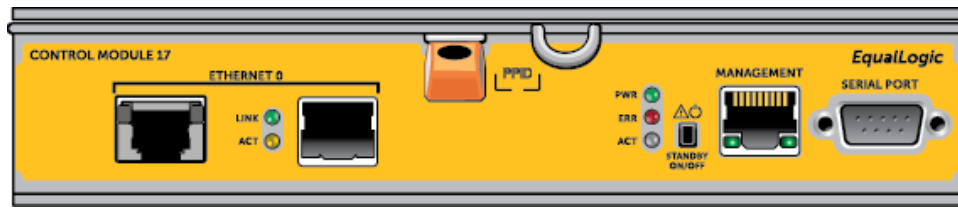
Figure 18: Correct Control Module Orientation

To install a control module:

1. Attach an electrostatic wrist strap, or similar protective device. *See "Protecting Hardware " on page 2.*
2. Push down on the orange release tab (callout 1 in following illustration) and swing the lever (callout 2 in following illustration) out.
3. Slide the control module into the chassis until you feel resistance, as shown in following illustration.

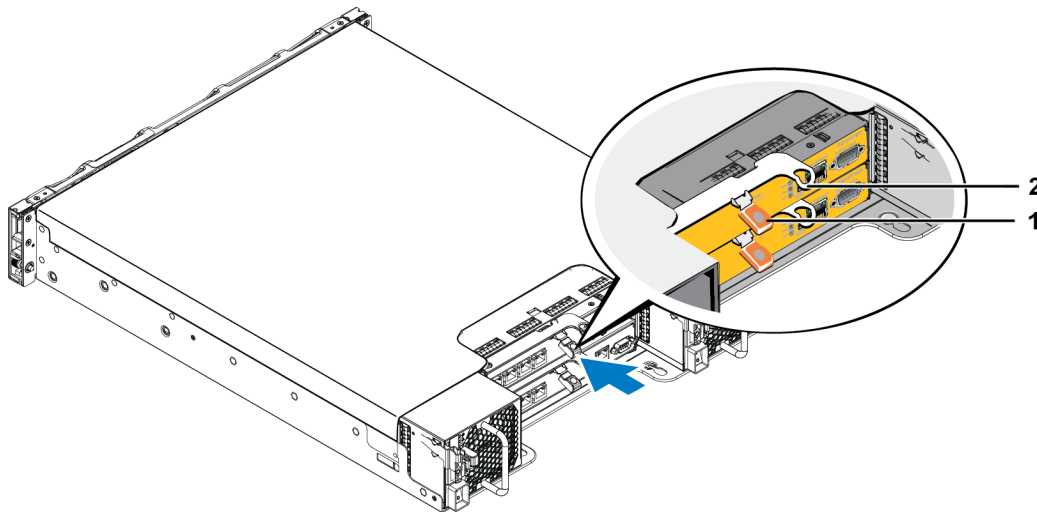
Figure 19: Installing a Control Module (2U Array)

4. Rotate the lever (callout 2 in illustration) inward, which pushes the control module completely into the slot. The latch on the lever will snap into place.
5. Reconnect the network cables.
6. If the array was shut down, turn on power to the array.
7. Make sure the control module is operational. *See Interpreting Control Module LEDs on page 19.*

When connected, the control module cache-to-flash module receives full charge. If it cannot be charged, its status is reported as BAD in the Group Manager GUI. You must remove the control module and replace it with another one.

If two control modules are installed in the array, but only one is shown in the GUI (or CLI), make sure that you have allowed enough time (minimum of five minutes) for the two control modules to boot and synchronize. When synchronization completes, a message will appear on the serial console (if connected), and the ACT LED on the secondary module will be orange.

If the GUI (or CLI) still shows only one control module after appropriate time has elapsed, the control module may not be properly installed. In this case, reinstall the control module.

After reinstalling the control module, if both control modules still do not appear in the GUI (or CLI), contact your support provider.

Replacing the MicroSD Card

Each control module includes a microSD card that contains the PS Series firmware.

If a control module fails, you'll need to remove the microSD card from the failed control module and install the card in the replacement control module. This will make sure that the new control module is running the same firmware as the other control module in the array.

Before you begin the procedure to replace a microSD card:

- Review [Replacing a Control Module on page 24](#) for information about removing and replacing a control module.
- Attach an electrostatic wrist strap, as described in [Protecting Hardware on page 2](#).

MicroSD Card Replacement Procedure

Use the following procedure for replacing the MicroSD card in your control module:

1. Remove the control module from the array. (As described in [Removing a Control Module on page 26](#).)
2. Remove the SD card from the control module. (As described in [Removing the MicroSD Card on page 29](#).)
3. Install the replacement SD card in the control module. (As described in [Inserting the MicroSD Card on page 30](#).)
4. Insert the control module into the array. (As described in [Installing a Control Module on page 27](#).)

Removing the MicroSD Card

Caution: To reduce the risk of losing or damaging the microSD card, do not remove it until you are ready to install it in the replacement control module.

1. Firmly push the card into its housing to release the spring mechanism (callout 2 in [Figure 20](#)). The microSD card will be partially ejected from the housing.
2. Gently pull the card straight out of the housing (callout 3 in [Figure 20](#)).
3. Place the microSD card on a flat surface where it will be protected from electrostatic charge.

Figure 20: Ejecting the MicroSD Card

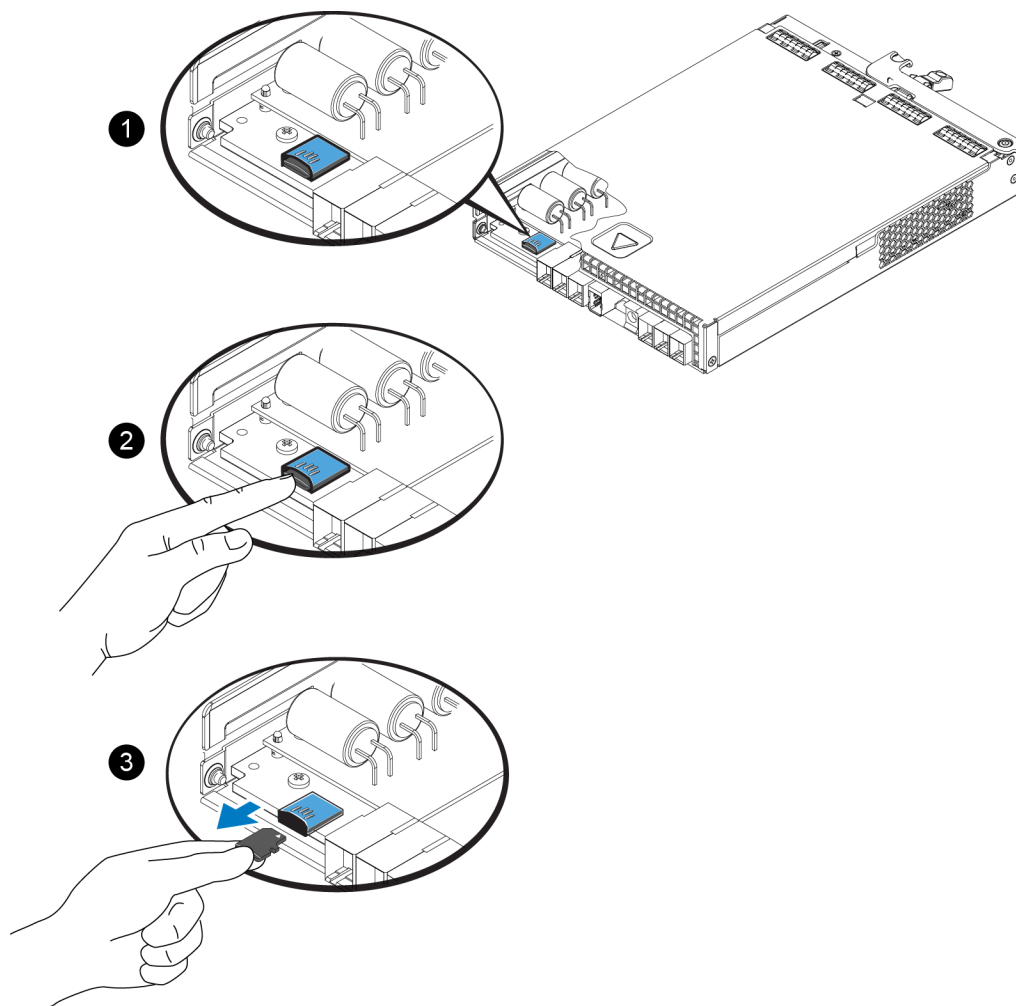

Inserting the MicroSD Card

1. Align the replacement microSD card so the arrow on the card points towards the housing ([Figure 21](#)). When correctly positioned, the gold contacts will be facing downward, and inward towards the housing.
2. Firmly press the card into the housing until it clicks into place. Confirm that the card is securely seated by pulling gently on the card afterwards.

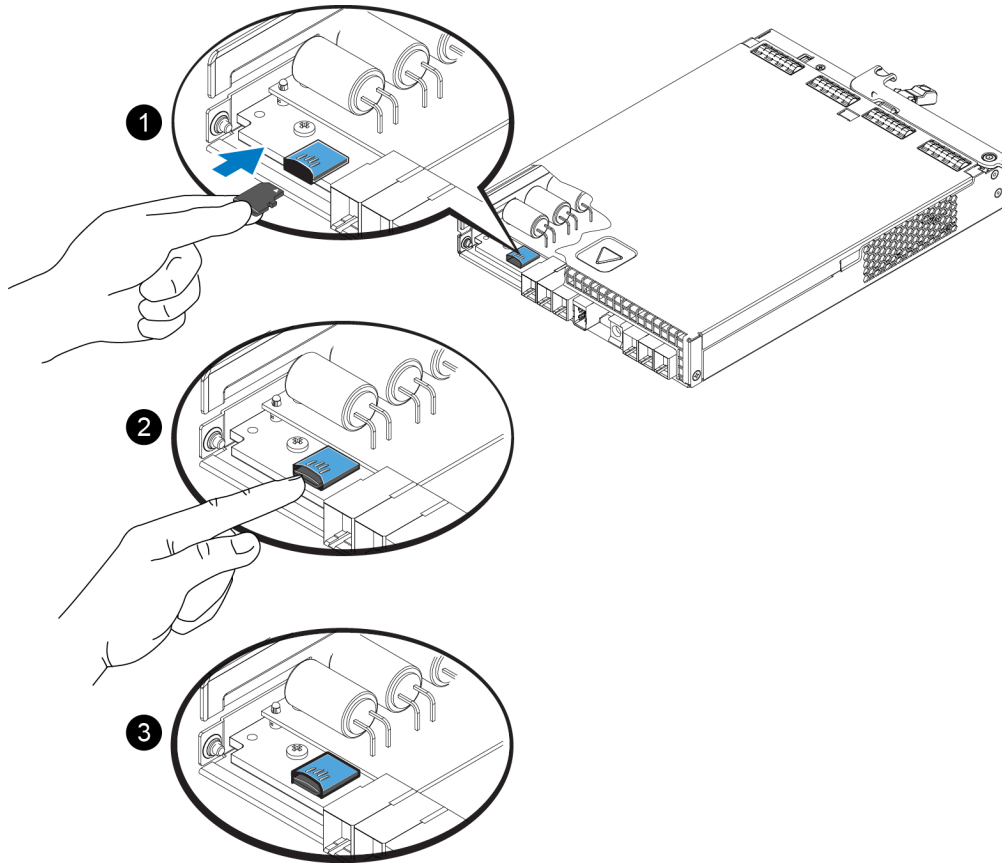
Figure 21: Inserting the MicroSD Card

3. Install the control module in the array. See [Installing a Control Module on page 27](#).
4. Make sure the control module is operational. See [Interpreting Control Module LEDs on page 19](#).

Advanced Networking Options

In addition to connecting all the Ethernet ports on both control modules to network switches, you can also optionally connect the Management port to a separate network switch.

Configuring a management port enables you to separate management traffic (creating and managing the group, members, volumes, replication, and so on) from the iSCSI data traffic (I/O between applications and volumes, and between replication partners).

Configuring the Management Port

Configuring the 10/100Mbps management port involves hardware steps and software steps. The management port is restricted to group management traffic only; it will not carry iSCSI I/O.

Note: This is considered an advanced configuration, available if your environment requires this level of security.

Hardware Steps

1. Make sure your network environment can support a dedicated management network, with a subnet that is separate from the subnets for iSCSI traffic.
2. On both control modules, connect the port labeled MANAGEMENT to the management network. The location of the management port is shown in the following figure.

Figure 22: Management Port Location

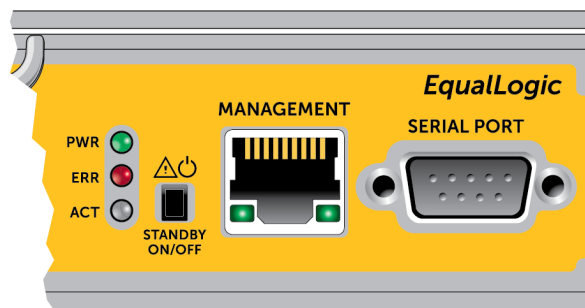

Software Steps

See the *PS Series Group Administration* guide for the procedure to configure the management network in the Group Manager GUI.

4 Maintaining Power Supply and Cooling Modules

The array can support two hot-swappable power supply and cooling modules.

The array can operate only temporarily with one module, but both modules must be present for long-term cooling of the array.

About Power Supplies

The PS Series array receives power from two power supplies (PSUs).

Each PSU has a 700W power supply. Each power supply has two cooling fans.

The fans that keep the array cool are integrated into the power supply modules and cannot be replaced separately. If a fan fails, you must replace the entire power supply module.

Identifying Power Supply Failures

You can identify a power supply and cooling module failure by any or all of the following:

- **LEDs** on the power supply and cooling modules. *See "Power Supply LEDs" on page 33* for details.
- **Messages** on the console, in the event log, or in the Group Manager GUI Alarms panel.
- **Group Manager GUI and CLI output.** The GUI Member Enclosure window or the CLI `member select show enclosure` command shows a power supply and cooling module failure.

Note: When viewing the rear of the array, power supply 0 is on the right, and power supply 1 is on the left.

Power Supply LEDs

The power supplies and cooling modules have LEDs that indicate their status.

[Figure 23](#) illustrates the power supply LEDs. [Table 7](#) describes these LEDs.

Figure 23: 700W Power Supply LEDs

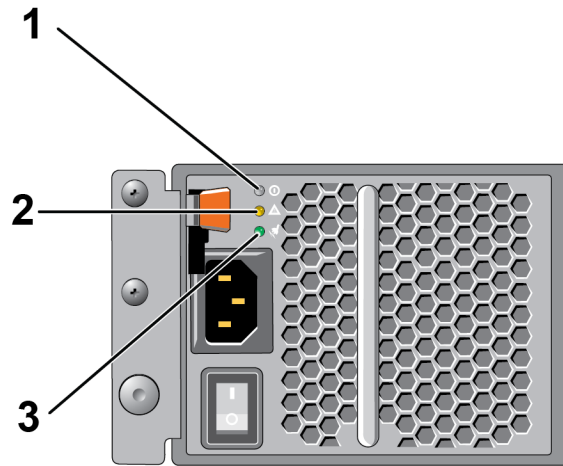

Table 7: Power Supply LED Descriptions

Item	LED	Color	State
1	DC power	Green	<p>ON—Normal operation. Power supply is connected to AC power and the power switch is on. The power supply module is supplying DC power to the array.</p> <p>OFF when any of these is true:</p> <ul style="list-style-type: none"> • The power switch is off • The power supply is not connected to AC power • There is a fault condition <p>For a list of warning or critical level faults, see the <i>Group Administration</i> manual.</p>
2	Fault	Amber	<p>On—Fault detected.</p> <p>OFF—OK.</p> <p>Blinks briefly when power is first turned on to the power supply module.</p> <p>For a list of warning or critical level faults, see the <i>Group Administration</i> manual.</p>
3	AC power	Green	<p>ON—Power supply module is connected to a source of AC power whether or not the power switch is on.</p> <p>OFF—Power supply module is completely disconnected from any source of AC power.</p>

Note: Under normal conditions, the AC and DC power LEDs will be lit at the same time.

Removing a Power Supply and Cooling Module

If a power supply and cooling module fails, you must replace the module as soon as possible, although an array can operate with only one working module. For proper array cooling, do not remove a failed module until you are ready to replace it.

Cautionary Note About Removing a Power Supply

You can remove a power supply and cooling module from an array without affecting array operation if the second module is installed and functioning. However, to maintain proper air flow in the array, **a power supply and cooling module must be replaced within five (5) minutes** of removing it. Otherwise, if possible, cleanly shut down the array before removing the module, as described in *Shutting Down and Restarting an Array on page 5*

How to Remove a Power Supply

Wear electrostatic protection when handling a power supply and cooling module. *See "Protecting Hardware " on page 2.*

To remove a power supply and cooling module, use the following steps and illustration:

1. Turn off the power switches on the power supply and cooling module.
2. Disengage the hook-and-loop fastener from around the power cable.
3. Remove the power cable.
4. With your right hand, hold the handle and push the orange release latch to the right with your thumb.
5. Pull the module from the slot, as shown in the following illustration.

Caution: The module is heavy; support it with two hands.

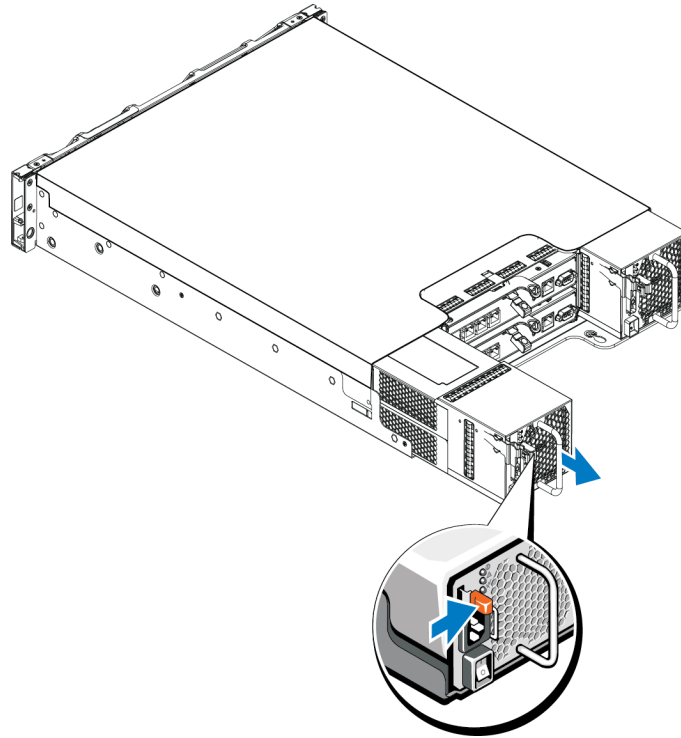
Figure 24: Removing a Power Supply and Cooling Module

Installing a Power Supply and Cooling Module

To install a power supply and cooling module, use the following steps and illustrations:

1. Hold the power supply module so that the orange release latch is on the upper left.
2. Slide the power supply and cooling module into the chassis until it is fully seated and the release latch clicks into place, as illustrated below.

Note: Before the power cable is connected, the fans start spinning, powered by the other power supply module.

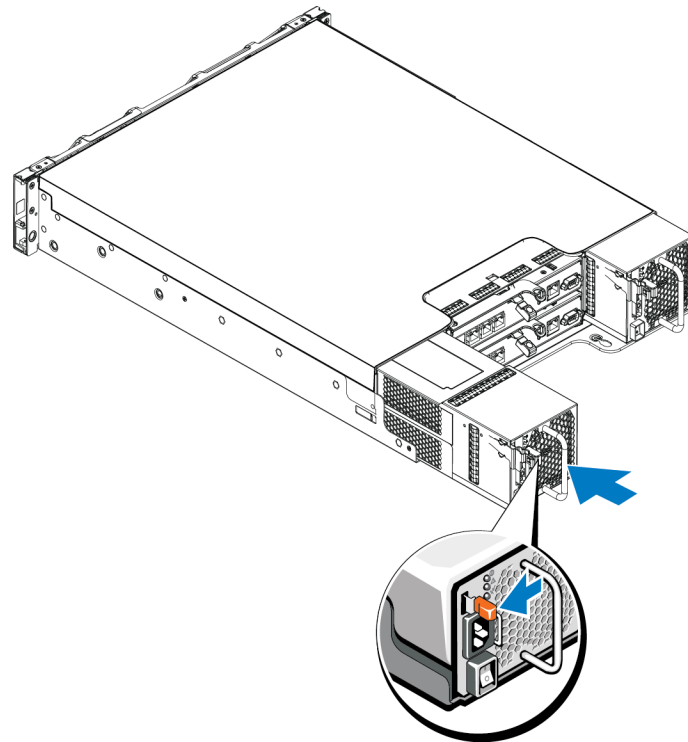
Figure 25: Inserting a Power Supply and Cooling Module

3. Make sure the power switch is in the OFF position.
4. Connect the power cable to the power supply and cooling module and plug the cable into a power outlet.
Note: The AC LED lights up when the AC power cable is connected, even if the switches on the power supply are off.
5. Secure the power cable using the hook-and-loop fastener strap, as shown in the following illustration.
6. Turn on the switch on the power supply and cooling module.

Figure 26: Securing the Power Cables

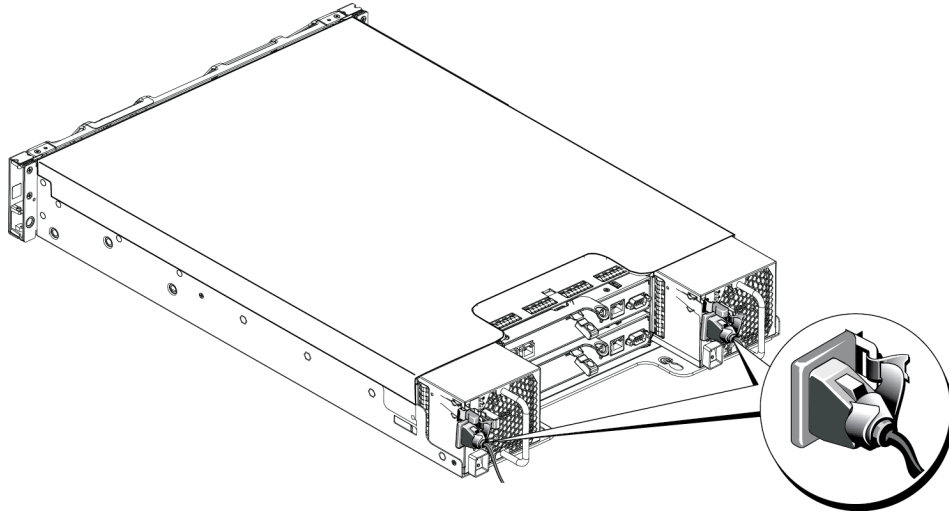

5 Troubleshooting Your Array

Safety First—For You and Your array

Many repairs may only be done by a certified service technician. You should only perform troubleshooting and simple repairs as authorized in your product documentation, or as directed by the online or telephone service and support team. Damage due to servicing that is not authorized by Dell is not covered by your warranty. Read and follow the safety instructions that came with the product.

Obtaining Technical Support and Customer Service

Dell's support service is available to answer your questions about PS Series arrays. If you have an Express Service Code, have it ready when you call. The code helps Dell's automated-support telephone system direct your call more efficiently.

Contacting Dell

Dell provides several online and telephone-based support and service options. Availability varies by country and product, and some services might not be available in your area.

For customers in the United States, call 800-945-3355.

Note: If you do not have access to an Internet connection, contact information is printed on your invoice, packing slip, bill, or Dell product catalog.

Use the following procedure to contact Dell for sales, technical support, or customer service issues:

1. Visit support.dell.com.
2. Verify your country or region in the Choose A Country/Region drop-down menu at the bottom of the window.
3. Click **Contact Us** on the left side of the window.
4. Select the appropriate service or support link based on your need.
5. Choose the method of contacting Dell that is convenient for you.

Determining Service Tag Information

Each array has a service tag with a number. You may need to provide this information to customer support when you contact us.

- The service tag label is visible on the front of the array, on the right bezel latch block.

Obtaining Component Diagnostics

You can collect diagnostic information for one or more members of a PS Series group through the Group Manager GUI or the CLI. See the *Group Administration* guide or the *CLI Reference* for more information.

Troubleshooting Array Startup Failure

If your system halts during startup, check if:

- The array fault LEDs are lit. See [Front-Panel Features and Indicators on page 3](#).
- There is a constant scraping or grinding sound when you access the hard drive. See [Obtaining Technical Support and Customer Service on page 39](#).

Troubleshooting Loss of Communication

For information about troubleshooting loss of communication, see *Network Requirements and Recommendations* in the *Installation Guide*.

Troubleshooting Array Connections

- Verify that the control module port link status LED and the control module status LED are solid green for each port that is connected to a cable. If the LEDs are not solid green, see [Control Module Features on page 17](#).
- Make sure that all the cables are attached correctly.

If the problem is not resolved, see [Obtaining Technical Support and Customer Service on page 39](#).

Troubleshooting External Connections

- Verify that the cables are connected to the correct Ethernet and, if applicable, Management ports before troubleshooting any external devices. For the location of the back-panel connectors on your array, see [Back-Panel Features and Indicators on page 5](#).
- Make sure that the power cables are securely attached to the power supply modules on your array.

Troubleshooting Power Supply and Cooling Modules

1. Locate the faulty power supply and determine the status of the LEDs.

If the power LED is not lit, check the power cord and power source into which the power supply is connected.

- Connect another device to the power source to verify if it is working.
- Connect the cable to a different power source.
- Replace the power cable.

If the problem is not resolved, or if the power supply's fault indicator is lit, see [Obtaining Technical Support and Customer Service on page 39](#).

Power supply and cooling modules are hot-swappable.

The array can operate on a single power supply; however both modules must be installed to ensure proper cooling. A single power supply and cooling module can be removed from a powered-on array for a maximum of five minutes. Beyond that time, the array may automatically shut down to prevent damage.

2. Reseat the power supply by removing and reinstalling it. See [Removing a Power Supply and Cooling Module on page 35](#).

Note: After installing a power supply, allow several seconds for the array to recognize the power supply and to determine if it is working properly.

If the problem is not resolved, see [Obtaining Technical Support and Customer Service on page 39](#).

Troubleshooting Array Cooling Problems

Check for and correct any of the following situations:

- Empty drive bays (no drive or drive blank).
- Ambient temperature is too high. See the Technical Specifications for the array in the *Installation and Setup Guide*.

- External airflow is obstructed.
- The power supply and cooling module is removed or has failed. See [Troubleshooting Power Supply and Cooling Modules on page 41](#).

If the problem is not resolved, see [Obtaining Technical Support and Customer Service on page 39](#).

Troubleshooting Control Modules

1. Remove the control module and verify that the pins on the backplane and control module are not bent. See [Replacing a Control Module on page 24](#).
2. Reinstall the control module and wait for 30 seconds. See [Replacing a Control Module on page 24](#).
3. Check the control module status LEDs. See [Interpreting Control Module LEDs on page 19](#) for more information.
4. If control module status LED is blinking amber (5 times per sequence), update the firmware to the latest supported firmware on both the control module. For more information about downloading the latest firmware, see the PS Series *Release Notes* and the document *Updating PS Series Storage Array Firmware*, available on the customer support site.
5. If the link status LEDs are not green:
 - a. Reseat the cables on the control modules and the switches.
 - b. Check the link status LED. If the link status LED is not green, proceed to the next step.
 - c. Replace the cables.

If the problem is not resolved, see [Obtaining Technical Support and Customer Service on page 39](#).

Troubleshooting Hard Drives

Check the hard drive indicators before removing the faulty drive from the array.

1. Remove the drive from the array. See [Removing a 2.5-inch Drive on page 10](#) and [Removing a 3.5-inch Drive on page 12](#).
2. Check the drive to make sure that the connectors are not damaged.
3. Reinstall the drive.
4. Verify that the control module port link status LED and the control module status LED are solid green for each port that is connected to a cable. If the LEDs are not solid green, see [Control Module Features on page 17](#).

If the problem is not resolved, see [Obtaining Technical Support and Customer Service on page 39](#).

P

power indicators	4
power supplies	
removing	35
PS Series array	
protecting from discharge	2

R

recommended tools	1
removing	
3.5-inch drive	10, 12
drive blank	14
requirements	
control modules	22
cooling	35
disks	9
firmware	21
power	35

S

safety	39
shutting down an array	5
status	
control modules	20

T

troubleshooting	39
connections	40
cooling problems	41
external connections	41
hard drives	42
loss of communication	40
power supply/cooling fan module	41
startup failure	40