

# Dell PowerEdge Command Line Reference Guide for the M I/O Aggregator

9.14.1.5

## Notes, cautions, and warnings

 **NOTE:** A NOTE indicates important information that helps you make better use of your product.

 **CAUTION:** A CAUTION indicates either potential damage to hardware or loss of data and tells you how to avoid the problem.

 **WARNING:** A WARNING indicates a potential for property damage, personal injury, or death.

<b>Chapter 1: About this Guide</b>	<b>16</b>
Objectives	16
Audience	16
Conventions	16
Information Icons	17
<b>Chapter 2: Before You Start</b>	<b>18</b>
Operational Modes	18
Default Settings	18
Other Auto-Configured Settings	19
DCB Support	19
FCoE Connectivity	19
iSCSI Operation	19
Link Aggregation	19
Uplink Failure Detection	20
VLANs	20
Where to Go From Here	21
<b>Chapter 3: CLI Basics</b>	<b>22</b>
Accessing the Command Line	22
Multiple Configuration Users	22
Navigating the CLI	23
Obtaining Help	23
Using the Keyword no Command	24
Filtering show Commands	25
Command Modes	26
<b>Chapter 4: File Management</b>	<b>28</b>
boot system gateway	28
boot system stack-unit	29
cd	29
copy	29
copy running-config startup-config	31
delete	31
dir	32
format flash	32
HTTP Copy via CLI	33
logging coredump stack-unit	33
pwd	34
rename	34
restore factory-defaults	35
show boot system	36
show file	37
show file-systems	37

show os-version.....	38
show running-config.....	39
show version.....	40
upgrade boot.....	41
upgrade system.....	42

**Chapter 5: Control and Monitoring..... 44**

asset-tag.....	45
clear alarms.....	45
clear command history.....	46
configure.....	46
debug cpu-traffic-stats.....	46
debug ifm trace-flags.....	47
disable.....	47
enable.....	48
end.....	48
exit.....	49
feature unique-name.....	49
ftp-server enable.....	50
ftp-server topdir.....	50
ftp-server username.....	51
hostname.....	51
http-server.....	52
ip telnet server enable.....	52
ip telnet source-interface.....	52
line.....	53
ping.....	53
reload.....	55
service timestamps.....	55
show alarms.....	56
show command-history.....	56
show configuration lock.....	57
show cpu-traffic-stats.....	58
show debugging.....	59
show diag.....	59
show environment.....	60
show inventory.....	61
show memory.....	62
show processes cpu.....	62
show processes ipc flow-control.....	64
show processes memory.....	66
show reset-reason.....	67
show revision.....	69
show server-interfaces.....	69
show system.....	70
show tech-support.....	72
show uplink brief.....	75
show util-threshold cpu.....	76
show util-threshold memory.....	76
ssh-peer-stack-unit.....	76

telnet.....	77
telnet-peer-stack-unit.....	77
terminal length.....	78
terminal monitor.....	78
terminal xml.....	79
trace route.....	79
undebg all.....	80
write.....	80
<b>Chapter 6: u-Boot.....</b>	<b>81</b>
boot change.....	81
boot selection.....	82
boot show net config retries.....	82
boot write net config retries.....	82
boot zero.....	82
default gateway.....	83
enable.....	83
help.....	83
ignore enable password.....	84
ignore startup-config.....	84
interface management ethernet ip address.....	85
no default gateway.....	85
no interface management ethernet ip address.....	85
reload.....	85
show boot blc.....	86
show boot selection.....	86
show bootflash.....	87
show bootvar.....	87
show default gateway.....	88
show interface management ethernet.....	88
show interface management port config.....	89
syntax help.....	89
<b>Chapter 7: Configuration Cloning.....</b>	<b>90</b>
clone-config apply.....	90
clone-config check.....	90
clone-config create.....	91
<b>Chapter 8: Data Center Bridging (DCB).....</b>	<b>92</b>
Fibre Channel over Ethernet for FC Flex IO Modules.....	93
advertise dcbx-appln-tlv.....	93
advertise dcbx-tlv.....	94
bandwidth-percentage.....	94
clear dcbx counters.....	95
clear ets counters.....	95
clear pfc counters.....	96
dcb-enable.....	96
dcb enable pfc-queues.....	96
dcb enable auto-detect on-next-reload.....	97

dcb-map stack-unit all stack-ports all.....	99
dcb pfc-shared-buffer-size.....	99
dcb pfc-total-buffer-size.....	100
dcb-buffer-threshold .....	100
dcb-policy buffer-threshold (Global Configuration).....	101
service-class buffer shared-threshold-weight.....	102
dcbx-port role.....	103
dcbx version.....	103
debug dcbx.....	104
fc-map.....	104
fcoe-map.....	105
fcoe priority-bits.....	106
iscsi priority-bits.....	106
keepalive.....	107
interface vlan (NPIV proxy gateway).....	107
pfc mode on.....	108
pfc no-drop queues.....	108
pfc priority.....	109
priority-group.....	110
priority-group bandwidth pfc.....	110
priority-pgid.....	111
qos-policy-output ets.....	112
scheduler.....	113
show dcb.....	114
show interface dcbx detail.....	114
show interface ets.....	117
show interface pfc.....	120
show interface pfc statistics.....	122
show qos dcb-map.....	123
show stack-unit stack-ports ets details.....	124
show stack-unit stack-ports pfc details.....	125
<b>Chapter 9: Dynamic Host Configuration Protocol.....</b>	<b>126</b>
clear ip dhcp client statistics.....	126
debug ip dhcp client events.....	127
debug ip dhcp client packets.....	127
ip address dhcp.....	128
release dhcp interface.....	128
renew dhcp interface.....	129
show ip dhcp client statistics.....	129
show ip dhcp lease.....	130
<b>Chapter 10: FC Flex IO Modules.....</b>	<b>131</b>
Fibre Channel over Ethernet for FC Flex IO Modules.....	131
NPIV Proxy Gateway for FC Flex IO Modules.....	131
description (for FCoE maps).....	132
fabric.....	132
fabric-id vlan.....	133
fcf-priority.....	134

fc-map.....	134
fcoe-map.....	135
fka-adv-period.....	136
interface vlan (NPIV proxy gateway).....	136
keepalive.....	137
show fc switch.....	137
show fcoe-map.....	138
show npiv devices.....	140
show running-config fcoe-map.....	142
<b>Chapter 11: FC FLEXIO FPORT.....</b>	<b>143</b>
active-zoneset .....	144
fabric.....	144
fc alias.....	145
fc zone.....	145
fc zoneset.....	146
fcoe-map.....	146
feature fc.....	147
show fc alias.....	148
show fc ns.....	148
show fc switch.....	150
show fc zone.....	150
show fc zoneset.....	151
show fcoe-map.....	152
<b>Chapter 12: FIP Snooping.....</b>	<b>153</b>
clear fip-snooping database interface vlan.....	153
clear fip-snooping statistics.....	154
feature fip-snooping.....	154
fip-snooping enable.....	154
fip-snooping fc-map.....	155
fip-snooping port-mode fcf.....	155
show fip-snooping statistics.....	156
debug fip-snooping.....	158
show fip-snooping config.....	159
show fip-snooping enode.....	159
show fip-snooping fcf.....	160
show fip-snooping sessions.....	160
show fip-snooping statistics.....	161
show fip-snooping system.....	164
show fip-snooping vlan.....	164
<b>Chapter 13: Internet Group Management Protocol (IGMP).....</b>	<b>166</b>
IGMP Commands.....	166
IGMP Snooping Commands.....	167
clear ip igmp groups.....	167
debug ip igmp.....	168
ip igmp group-join-limit.....	168
ip igmp querier-timeout.....	168

ip igmp query-interval.....	169
ip igmp query-max-resp-time.....	169
ip igmp snooping enable.....	170
ip igmp snooping fast-leave.....	170
ip igmp snooping flood.....	170
ip igmp snooping last-member-query-interval.....	171
ip igmp snooping mrouter.....	171
ip igmp snooping querier.....	172
ip igmp version.....	172
show ip igmp groups.....	173
show ip igmp interface.....	174
show ip igmp snooping mrouter.....	175

**Chapter 14: Interfaces.....176**

Port Interface Commands.....	177
Port Channel Commands.....	177
Time Domain Reflectometer (TDR) Commands.....	177
Virtual LAN (VLAN) Commands.....	178
auto vlan.....	178
channel-member.....	178
clear counters.....	179
clear mac-address-table dynamic.....	180
default vlan-id.....	181
description.....	181
feature fc.....	182
flowcontrol.....	182
interface.....	184
interface ManagementEthernet.....	184
interface port-channel.....	185
interface range.....	186
interface vlan.....	187
intf-type cr4 autoneg.....	188
keepalive.....	188
minimum-links.....	189
monitor interface.....	189
mtu.....	191
name.....	192
negotiation auto.....	193
remote-fault-signaling rx.....	194
show config (INTERFACE mode).....	195
show config (from INTERFACE RANGE mode).....	195
show config (from INTERFACE VLAN mode).....	196
show config (from PROTOCOL LLDP mode).....	196
show interfaces.....	197
show interfaces configured.....	200
show interfaces description.....	200
show interfaces port-channel.....	201
show interfaces stack-unit.....	204
show interfaces status.....	205
show interfaces switchport.....	205



show tdr.....	207
show vlan.....	208
shutdown.....	209
source (port monitoring for 40-Gigabit Ethernet).....	210
speed (for 1000/10000 interfaces).....	210
stack-unit portmode.....	211
wavelength.....	212
tdr-cable-test.....	212
vlan tagged (CMC).....	213
vlan untagged (CMC).....	214
<b>Chapter 15: IPv4 Routing.....</b>	<b>215</b>
clear tcp statistics.....	215
debug ip dhcp.....	215
debug ip icmp.....	216
ip route.....	217
management route.....	218
show arp.....	219
show ip interface.....	220
show ip management-route.....	222
show ip multicast-cam stack-unit.....	222
show ip route.....	223
show tcp statistics.....	225
<b>Chapter 16: iSCSI Optimization.....</b>	<b>227</b>
advertise dcbx-app-tlv.....	227
iscsi aging time.....	227
iscsi cos.....	228
iscsi enable.....	229
iscsi priority-bits.....	229
iscsi profile-compellent.....	229
iscsi target port.....	230
show iscsi.....	230
show iscsi sessions.....	231
show iscsi sessions detailed.....	232
<b>Chapter 17: Isolated Networks.....</b>	<b>233</b>
io-aggregator isolated-network vlan.....	233
show io-aggregator isolated-networks .....	233
<b>Chapter 18: Link Aggregation Control Protocol (LACP).....</b>	<b>235</b>
auto-lag enable.....	235
clear lacp counters.....	235
debug lacp.....	236
delay-restore abort-threshold.....	236
io-aggregator auto-lag enable.....	237
lacp link-fallback.....	237
lacp long-timeout.....	238
lacp port-priority.....	238

port-channel mode.....	239
port-channel-protocol lacp.....	239
show interfaces port-channel.....	240
show io-aggregator auto-lag status.....	242
show lacp.....	242
show link-bundle-distribution port-channel.....	244
show port-channel-flow.....	244
<b>Chapter 19: Layer 2.....</b>	<b>246</b>
MAC Addressing Commands.....	246
Virtual LAN (VLAN) Commands.....	246
clear mac-address-table dynamic.....	246
description.....	247
mac-address-table aging-time.....	247
mac-address-table static.....	248
mac-address-table station-move refresh-arp.....	248
show cam mac stack-unit.....	249
show mac-address-table.....	249
<b>Chapter 20: Link Layer Discovery Protocol (LLDP).....</b>	<b>252</b>
advertise dot3-tlv.....	252
advertise management-tlv.....	253
advertise interface-port-desc.....	253
clear lldp counters.....	254
clear lldp neighbors.....	254
debug lldp interface.....	254
disable.....	255
hello.....	256
multiplier.....	256
protocol lldp (Configuration).....	256
protocol lldp (Interface).....	257
show lldp neighbors.....	257
show lldp statistics.....	258
<b>Chapter 21: Object Tracking.....</b>	<b>259</b>
IPv4 Object Tracking Commands.....	259
debug track.....	259
delay.....	260
description.....	260
show running-config track.....	260
show track.....	261
threshold metric.....	263
track interface ip routing.....	263
track interface line-protocol.....	264
track ip route metric threshold.....	265
track ip route reachability.....	265
track resolution ip route.....	266
IPv6 Object Tracking Commands.....	267
show track ipv6 route.....	267

track interface ipv6 routing.....	268
track ipv6 route metric threshold.....	269
track ipv6 route reachability.....	270
track resolution ipv6 route.....	270
<b>Chapter 22: Port Monitoring.....</b>	<b>272</b>
description.....	272
monitor session.....	273
show config.....	273
show monitor session.....	274
show running-config monitor session.....	274
source (port monitoring).....	275
<b>Chapter 23: Quality of Service (QoS).....</b>	<b>276</b>
Per-Port QoS Commands.....	276
Policy-Based QoS Commands.....	276
bandwidth-percentage.....	276
description.....	277
dot1p-priority.....	277
policy-aggregate.....	278
policy-map-output.....	279
qos-policy-output.....	279
rate-shape.....	280
service-class bandwidth-percentage.....	280
service-class dot1p-mapping.....	281
service-class dynamic dot1p.....	282
service-policy output.....	282
service-queue.....	283
show qos dcb-map.....	284
show qos dot1p-queue-mapping.....	284
show qos qos-policy-output.....	285
<b>Chapter 24: Security.....</b>	<b>286</b>
AAA Accounting Commands.....	286
aaa accounting.....	286
aaa accounting suppress.....	287
aaa authorization commands.....	288
aaa authorization config-commands.....	288
aaa authorization exec.....	289
accounting.....	289
show accounting.....	290
Authentication and Password Commands.....	290
aaa authentication enable.....	290
aaa authentication login.....	291
aaa reauthenticate enable.....	292
banner exec.....	293
banner login.....	294
banner motd.....	295
debug radius.....	295

debug tacacs+.....	296
exec-banner.....	296
ip radius source-interface.....	297
ip tacacs source-interface.....	297
login authentication.....	298
secure-cli enable.....	298
RADIUS Commands.....	299
radius-server deadtime.....	299
radius-server host.....	299
radius-server key.....	300
radius-server retransmit.....	301
radius-server timeout.....	301
show privilege.....	302
Suppressing AAA Accounting for Null Username Sessions.....	302
TACACS+ Commands.....	302
TACACS+ Accounting.....	302
tacacs-server host.....	303
tacacs-server key.....	304
timeout login response.....	305
SSH Server and SCP Commands.....	305
enable password.....	305
enable restricted.....	306
enable sha256-password.....	307
service password-encryption.....	307
show ip ssh.....	308
show ip ssh client-pub-keys.....	308
show ip ssh rsa-authentication.....	309
show users.....	309
ssh.....	310
username.....	311
ICMP Commands.....	312
drop icmp.....	313
<b>Chapter 25: Simple Network Management Protocol (SNMP) and Syslog.....</b>	<b>314</b>
SNMP Commands.....	314
show snmp.....	315
show snmp engineID.....	315
show snmp group.....	316
show snmp supported-mibs.....	317
show snmp supported-traps.....	317
show snmp user.....	318
snmp context.....	319
snmp-server community.....	319
snmp-server context.....	320
snmp-server enable traps.....	321
snmp-server engineID.....	321
snmp-server group.....	322
snmp-server host.....	323
snmp-server user.....	325
snmp-server view.....	327

<b>Chapter 26: Stacking Commands.....</b>	<b>328</b>
power-cycle stack-unit.....	328
reset stack-unit.....	329
show system stack-ports.....	330
show system stack-unit fanout.....	331
show system stack-unit iom-mode.....	331
show system stack-unit iom-uplink-speed.....	332
show system stack-unit stack-group.....	332
stack-unit iom-mode.....	333
stack-unit iom-mode uplink-speed.....	334
stack-unit priority.....	334
stack-unit renumber.....	335
<b>Chapter 27: Storm Control.....</b>	<b>336</b>
io-aggregator broadcast storm-control.....	336
show io-aggregator broadcast storm-control status.....	337
storm-control PFC/LLFC.....	337
storm-control multicast (Interface).....	338
storm-control broadcast (Interface).....	338
show storm-control unknown-unicast.....	338
storm-control unknown-unicast (Interface).....	339
<b>Chapter 28: SupportAssist.....</b>	<b>340</b>
eula-consent.....	340
support-assist.....	342
support-assist activate.....	342
support-assist activity.....	343
SupportAssist Commands.....	343
activity.....	343
contact-company.....	344
contact-person.....	344
enable.....	345
server.....	346
SupportAssist Activity Commands.....	346
action-manifest get.....	346
action-manifest install.....	347
action-manifest remove.....	348
action-manifest show.....	348
enable.....	349
SupportAssist Company Commands.....	349
address.....	349
street-address.....	350
territory.....	351
SupportAssist Person Commands.....	351
email-address.....	351
phone.....	352
preferred-method.....	353
time-zone.....	353

SupportAssist Server Commands.....	354
proxy-ip-address.....	354
enable.....	355
url.....	355
show eula-consent.....	356
show running-config.....	357
show support-assist status.....	358
<b>Chapter 29: System Time.....</b>	<b>359</b>
calendar set.....	359
clock read-calendar.....	360
clock set.....	360
clock summer-time date.....	361
clock summer-time recurring.....	362
clock timezone.....	363
clock update-calendar.....	363
ntp control-key-passwd.....	364
ntp server.....	364
show calendar.....	365
show clock.....	365
<b>Chapter 30: Uplink Failure Detection (UFD).....</b>	<b>367</b>
clear ufd-disable.....	367
debug uplink-state-group.....	368
defer-timer.....	368
description.....	368
downstream.....	369
downstream auto-recover.....	370
downstream disable links.....	370
enable.....	371
show running-config uplink-state-group.....	371
show uplink-state-group.....	372
uplink-state-group.....	373
upstream.....	373
<b>Chapter 31: Virtual Link Trunking (VLT).....</b>	<b>375</b>
back-up destination.....	375
clear vlt statistics.....	376
lACP ungroup member-independent.....	376
peer-link port-channel.....	377
show vlt backup-link.....	377
show vlt brief.....	378
show vlt detail.....	378
show vlt mismatch.....	379
show vlt role.....	379
show vlt statistics.....	380
stack-unit iom-mode.....	381
system-mac.....	381
unit-id.....	382

vlt domain.....	382
vlt-peer-lag port-channel.....	383
<b>Chapter 32: Debugging and Diagnostics.....</b>	<b>384</b>
Offline Diagnostic Commands.....	384
Hardware Commands.....	384
clear hardware stack-unit.....	385
diag stack-unit.....	385
hardware watchdog.....	386
offline stack-unit.....	387
show diag.....	387
show hardware stack-unit.....	389
show hardware counters interface.....	397
show hardware buffer interface.....	398
show hardware system-flow.....	399
show hardware buffer-stats-snapshot.....	401
show hardware stack-unit buffer-stats-snapshot (Total Buffer Information).....	404
show hardware drops.....	406
<b>Appendix A: Internet Control Message Protocol (ICMP) Message Types.....</b>	<b>409</b>

# About this Guide

This book provides information about the Dell Networking OS command line interface (CLI) on the Dell PowerEdge M I/O Aggregator.

This book also includes information about the protocols and features found in the Dell Networking OS and on the Dell Networking systems supported by the Dell Networking OS.

## References

For more information about your system, refer to the following documents:

- *Dell PowerEdge M I/O Aggregator Configuration Guide*
- *Dell PowerEdge M I/O Aggregator Getting Started Guide*
- *Release Notes for the Dell PowerEdge M I/O Aggregator*

### Topics:

- [Objectives](#)
- [Audience](#)
- [Conventions](#)

## Objectives

This book is intended as a reference guide for the Aggregator CLI commands, with detailed syntax statements, along with usage information and sample output.

This guide contains an Appendix with a list of the request for comment (RFCs) and management information base files (MIBs) supported.

 **NOTE:** For more information about when to use the CLI commands, refer to the *Dell PowerEdge M I/O Aggregator Configuration Guide* for your system.

## Audience

This book is intended for system administrators who are responsible for configuring or maintaining networks. This guide assumes that you are knowledgeable in Layer 2 and Layer 3 networking technologies.

## Conventions

This book uses the following conventions to describe command syntax.

<b>Keyword</b>	Keywords are in Courier font and must be entered in the CLI as listed.
<b><i>parameter</i></b>	Parameters are in italics and require a number or word to be entered in the CLI.
<b>{X}</b>	Keywords and parameters within braces must be entered in the CLI.
<b>[X]</b>	Keywords and parameters within brackets are optional.
<b>x y</b>	Keywords and parameters separated by a bar require you to choose one option.
<b>x  y</b>	Keywords and parameters separated by a double bar allow you to choose any or all of the options.



## Information Icons

This book uses the following information symbols:

 **NOTE:** The Note icon signals important operational information.

 **CAUTION:** The Caution icon signals information about situations that could result in equipment damage or loss of data.

 **NOTE:** The Warning icon signals information about hardware handling that could result in injury.

## Before You Start

By following the instructions in the *Dell PowerEdge M I/O Aggregator Getting Started Guide* that is shipped with the product, you install the Aggregator in a Dell PowerEdge M1000e Enclosure.

The Aggregator installs with zero-touch configuration. After you power it on, an Aggregator boots up with default settings and auto-configures with software features enabled. This chapter describes the default settings and software features that are automatically configured at startup. Use the tasks described in the other chapters to reconfigure the Aggregator for customized network operation.

### Topics:

- [Operational Modes](#)
- [Default Settings](#)
- [Other Auto-Configured Settings](#)
- [Where to Go From Here](#)

## Operational Modes

The FN I/O Module supports four operational modes. Select the operational mode that meets your deployment needs. To enable a new operational mode, reload the switch.

- Standalone mode — `stack-unit unit iom-mode standalone`. This is the default mode for IOA. It is fully automated zero-touch mode that allows you to configure VLAN memberships. (Manageable through CMC also)
- Programmable MUX mode (PMUX) — `stack-unit unit iom-mode programmable-mux`. Select this mode to configure PMUX mode CLI commands.
- Stacking mode — `stack-unit unit iom-mode stacking`. Select this mode to stack up to six IOA stack units as a single logical switch. The stack units can be in the same or on different chassis. This is a low-touch mode where all configuration except VLAN membership is automated. To enable VLAN, you must configure it. In this operational mode, base module links are dedicated to stacking.
- Virtual Link Trunking mode (VLT) — `stack-unit unit iom-mode vlt`. Select this mode to multi-home server interfaces to different IOA modules. This is a low-touch mode where all configuration except VLAN membership is automated. To enable VLAN, you must configure it. In this mode, base module links are dedicated to VLT interconnect.

For more information, see the *Dell PowerEdge M I/O Aggregator Configuration Guide*.

## Default Settings

The I/O Aggregator provides zero-touch configuration with the following default configuration settings:

- Default user name (**root**)
- Password (**calvin**)
- VLAN (**vlan1**) and IP address for in-band management (**DHCP-assigned**)
- IP address for out-of-band (OOB) management (**DHCP-assigned**)
- Read-only SNMP community name (**public**)
- Broadcast storm control (**enabled**)
- Unregistered Multicast Packets flooding (**enabled**)
- IGMP snooping in all VLANs except the default VLAN (**enabled**)
- VLAN configuration (**all ports belong to all VLANs**)

You can change any of these default settings using the CLI. Refer to the appropriate chapter for details.

**NOTE:** You can also change many of the default settings using the chassis management controller (CMC) interface. For information about how to access the CMC to configure an Aggregator, refer to the *Dell PowerEdge M1000e Enclosure Hardware Owner's Manual* or *Dell Chassis Management Controller (CMC) User's Guide* on the Dell Support website at <http://support.dell.com/support/edocs/systems/pem/en/index.htm>.

# Other Auto-Configured Settings

After the Aggregator powers on, it auto-configures and is operational with software features enabled, including:

- VLANs: All ports are configured as members of all (4094) VLANs. All VLANs are up and can send or receive layer 2 traffic. For more information, refer to [VLANs](#).
- Data Center Bridging Capability Exchange Protocol (DCBX)
- Fibre Channel over Ethernet (FCoE) connectivity
- FCoE Initiation Protocol (FIP) snooping
- Hybrid ports: Ports are administratively up and auto-configured to operate as hybrid ports to transmit tagged and untagged VLAN traffic.
- iSCSI optimization
- IGMP snooping
- Jumbo frames: Ports are set to a maximum MTU of 12,000 bytes by default.
- Link aggregation: All uplink ports are configured in a single LAG (LAG 128).
- Link Layer Discovery Protocol (LLDP): Enabled on all ports.
- Link tracking: Enables server-facing links to be brought up only if the uplink port-channel (LAG 128) is up.
- Stacking: Stacking is supported only on the 40GbE ports on the base module. A single stack is limited to six Aggregators in the same chassis. Up to three stacks are supported in an M1000e chassis. To configure a switch stack, you must use the CLI. For more information, refer to [Stacking Commands](#).

## DCB Support

DCB enhancements for data center networks are supported to eliminate packet loss and provision links with required bandwidth.

The Aggregator provides zero-touch configuration for DCB. The Aggregator auto-configures DCBX port roles to match the DCBX configuration in the ToR switches to which it connects through its uplink ports.

The Aggregator supports DCB only in standalone mode and not in the stacking mode.

## FCoE Connectivity

Many data centers use Fibre Channel (FC) in storage area networks (SANs). Fibre Channel over Ethernet (FCoE) encapsulates Fibre Channel frames over Ethernet networks.

On an Aggregator, the internal ports support FCoE connectivity and connect to the converged network adapter (CNA) in blade servers. FCoE allows Fibre Channel to use 10-Gigabit Ethernet networks while preserving the Fibre Channel protocol.

The Aggregator also provides zero-touch configuration for FCoE configuration. The Aggregator auto-configures to match the FCoE settings used in the ToR switches to which it connects through its uplink ports.

## iSCSI Operation

Support for iSCSI traffic is turned on by default when the Aggregator powers up. No configuration is required.

When the Aggregator powers up, it monitors known TCP ports for iSCSI storage devices on all interfaces. When a session is detected, an entry is created and monitored as long as the session is active.

The Aggregator also detects iSCSI storage devices on all interfaces and auto-configures to optimize performance. Performance optimization operations, such as Jumbo frame size support, and disabling storm control on interfaces connected to an iSCSI equallogic (EQL) storage device, are applied automatically.

CLI configuration is necessary only when the configuration includes iSCSI storage devices that cannot be automatically detected and when non-default QoS handling is required.

## Link Aggregation

In Standalone, VLT, and Stacking modes, all uplink ports are configured in a single LAG (LAG 128). There can be multiple uplink LAGs in programmable-mux mode. Server-facing ports are auto-configured as part of link aggregation groups if the corresponding server is configured for LACP-based NIC teaming. Static LAGs are supported in PUX mode.

**NOTE:** The recommended LACP timeout is Long-Timeout mode.

## Uplink Failure Detection

By default, all server-facing ports are tracked by the operational status of the uplink LAG. If the uplink LAG goes down, the Aggregator loses its connectivity and is no longer operational; all server-facing ports are brought down.

**NOTE:** If installed servers do not have connectivity to a ToR switch, check the Link Status LED of uplink ports on the Aggregator. If all LEDs are ON, check the LACP configuration on the ToR switch that is connected to the Aggregator to ensure the LACP is correctly configured.

## VLANS

By default, all Aggregator ports belong to all 4094 VLANs and are members of untagged VLAN 1. You can use the CLI or CMC interface to configure only the required VLANs on a port.

When you configure VLANs on server-facing interfaces (ports 1 to 32), you can assign VLANs to a port or a range of ports by entering the `vlan tagged` or `vlan untagged` commands in interface configuration mode; for example:

```
Dell(conf)# interface tengigabitethernet 0/2 - 4
Dell(conf-if-range-te-0/2-4)# vlan tagged 5,7,10-12
Dell(conf-if-range-te-0/2-4)# vlan untagged 3
```

**NOTE:** You can also use the CMC interface to configure VLANs.

### Uplink LAG

The tagged VLAN membership of the uplink LAG is automatically configured based on the tagged and untagged VLAN configuration of all server-facing ports (ports 1 to 32).

The untagged VLAN used for the uplink LAG is always the default VLAN.

### Server-Facing LAGs

The tagged VLAN membership of a server-facing LAG is automatically configured based on the server-facing ports that are members of the LAG.

The untagged VLAN of a server-facing LAG is configured based on the untagged VLAN to which the lowest numbered server-facing port in the LAG belongs.

**NOTE:** Dell Networking recommends that you configure the same VLAN membership on all LAG member ports.

### Stacking Mode

When you configure an Aggregator to operate in stacking mode (See “Configuring and Bringing Up a Stack” in the Dell Networking Configuration Guide for the M I/O Aggregator), VLANs are reconfigured as follows:

If an Aggregator port belonged to all 4094 VLANs in standalone mode (default), all VLAN membership is removed and the port is assigned only to default VLAN 1. You must configure additional VLAN membership as necessary.

If you had manually configured an Aggregator port to belong to one or more VLANs (non-default) in standalone mode, the VLAN configuration is retained in stacking mode only on the master switch

When you reconfigure an Aggregator from stacking to standalone mode:

Aggregator ports that you manually configured for VLAN membership in stacking mode retain their VLAN configuration in standalone mode.

To restore the default auto-VLAN mode of operation (in which all ports are members of all 4094 VLANs) on a port, enter the `auto vlan` command; for example:

```
Dell(conf)# interface tengigabitethernet 0/2
Dell(conf-if-te-0/2)# auto vlan
```

To get the default standalone mode configurations:

1. Delete the **startup-config** file and reboot the system.
2. Restore to factory default settings.

3. Configure **auto vlan** command on all the server ports.

## Where to Go From Here

You can customize the Aggregator for use in your data center network as necessary. To perform additional switch configuration, do one of the following:

- For remote out-of-band management, enter the OOB management interface IP address into a Telnet or SSH client and log in to the switch using the user ID and password to access the CLI.
- For local management using the CLI, use the attached console connection.
- For remote in-band management from a network management station, enter the VLAN IP address of the management port and log in to the switch to access the CLI.

If you installed the Aggregator in a stack, you can configure additional settings for switch stacking

In case of a Dell Networking OS upgrade, you can check to see that an Aggregator is running the latest Dell Networking OS version by entering the [show version](#) command. To download a Dell Networking OS version, go to <http://support.dell.com>.

Refer to the appropriate chapter for detailed information on how to configure specific software settings.

# CLI Basics

This chapter describes the command line interface (CLI) structure and command modes. The Dell operating system commands are in a text-based interface that allows you to use the launch commands, change command modes, and configure interfaces and protocols.

## Topics:

- [Accessing the Command Line](#)
- [Multiple Configuration Users](#)
- [Navigating the CLI](#)
- [Obtaining Help](#)
- [Using the Keyword no Command](#)
- [Filtering show Commands](#)
- [Command Modes](#)

## Accessing the Command Line

When the system boots successfully, you are positioned on the command line in EXEC mode and not prompted to log in. You can access the commands through a serial console port or a Telnet session. When you Telnet into the switch, you are prompted to enter a login name and password.

### Example

```
telnet 172.31.1.53
Trying 172.31.1.53...
Connected to 172.31.1.53.
Escape character is '^]'.
Login: username
Password:
Dell>
```

After you log in to the switch, the prompt provides you with the current command-level information. For example:

Prompt	CLI Command Mode
<b>Dell&gt;</b>	EXEC
<b>Dell#</b>	EXEC Privilege
<b>Dell (conf) #</b>	CONFIGURATION

 **NOTE:** For a list of all the command mode prompts, refer to the [Command Modes](#) Modes section.

## Multiple Configuration Users

When a user enters CONFIGURATION mode and another user is already in CONFIGURATION mode, the Dell operating system generates an alert warning message similar to the following:

```
Dell#conf
% Warning: The following users are currently configuring the system:
User "" on line console0
User "admin" on line vty0 ( 123.12.1.123 )
User "admin" on line vty1 ( 123.12.1.123 )
```

```
User "Irene" on line vty3 ( 123.12.1.321 )
Dell#conf
```

When another user enters CONFIGURATION mode, the Dell Networking OS sends a message similar to the following:

```
% Warning: User "admin" on line vty2 "172.16.1.210" is in configuration
```

In this case, the user is “admin” on vty2.

## Navigating the CLI

The Dell Networking OS displays a CLI prompt comprised of the host name and CLI mode.

- Host name is the initial part of the prompt and is “Dell” by default. You can change the host name with the `hostname` command.
- CLI mode is the second part of the prompt and reflects the current CLI mode. For a list of the Dell Networking OS command modes, refer to the command mode list in the [Accessing the Command Line](#) section.

The CLI prompt changes as you move up and down the levels of the command structure. Starting with CONFIGURATION mode, the command prompt adds modifiers to further identify the mode. For more information about command modes, refer to the [Command Modes](#) section.

**Table 1. CLI Command Modes and Prompts**

Prompt	CLI Command Mode
Dell>	EXEC
Dell#	EXEC Privilege
Dell(conf)#	CONFIGURATION
Dell(conf-if-te-0/1)# Dell(conf-if-vl-1)# Dell(conf-if-ma-0/0)# Dell(conf-if-range)#	INTERFACE
Dell(conf-line-console)# Dell(conf-line-vty)#	LINE
Dell(conf-mon-sess)#	MONITOR SESSION

## Obtaining Help

As soon as you are in a command mode there are several ways to access help.

**To obtain a list of keywords at any command mode:** Type a ? at the prompt or after a keyword. There must always be a space before the ?.

**To obtain a list of keywords with a brief functional description:** Type `help` at the prompt.

**To obtain a list of available options:** Type a keyword and then type a space and a ?.

**To obtain a list of partial keywords using a partial keyword:** Type a partial keyword and then type a ?.

## Example

The following is an example of typing `ip ?` at the prompt:

```
Dell(conf)#ip ?
igmp      Internet Group Management Protocol
route     Establish static routes
telnet    Specify telnet options
```

When entering commands, you can take advantage of the following timesaving features:

- The commands are not case-sensitive.
- You can enter partial (truncated) command keywords. For example, you can enter `int tengig int` for the `interface tengigabitethernet interface` command.
- To complete keywords in commands, use the TAB key.
- To display the last enabled command, use the up Arrow key.
- To erase the previous character, use either the Backspace key or Delete key.
- To navigate left or right in the Dell Networking OS command line, use the left and right Arrow keys.

The shortcut key combinations at the Dell Networking OS command line are as follows:

Key Combination	Action
<b>CNTL-A</b>	Moves the cursor to the beginning of the command line.
<b>CNTL-B</b>	Moves the cursor back one character.
<b>CNTL-D</b>	Deletes the character at the cursor.
<b>CNTL-E</b>	Moves the cursor to the end of the line.
<b>CNTL-F</b>	Moves the cursor forward one character.
<b>CNTL-I</b>	Completes a keyword.
<b>CNTL-K</b>	Deletes all the characters from the cursor to the end of the command line.
<b>CNTL-L</b>	Re-enters the previous command.
<b>CNTL-N</b>	Returns to the more recent commands in the history buffer after recalling commands with Ctrl-P or the up Arrow key.
<b>CNTL-P</b>	Recalls commands, beginning with the last command.
<b>CNTL-U</b>	Deletes the line.
<b>CNTL-W</b>	Deletes the previous word.
<b>CNTL-X</b>	Deletes the line.
<b>CNTL-Z</b>	Comes back to EXEC mode from any CONFIGURATION mode.
<b>Esc B</b>	Moves the cursor back one word.
<b>Esc F</b>	Moves the cursor forward one word.
<b>Esc D</b>	Deletes all the characters from the cursor to the end of the word.

## Using the Keyword no Command

To disable, delete or return to default values, use the `no` form of the commands.

For most commands, if you type the keyword `no` in front of the command, you disable that command or delete it from the running configuration. In this guide, the `no` form of the command is described in the Syntax portion of the command description. For example:

<b>Syntax</b>	<code>no {boot   default   enable   ftp-server   hardware   hostname   ip   line   logging   monitor   service   io-aggregator broadcast storm-control   snmp-server   username}</code>
<b>Defaults</b>	None



**Command Modes** CONFIGURATION

**Supported Modes** All Modes

Command History	Version	Description
	<b>9.4(0.0)</b>	Supported on the FN I/O Aggregator.
	<b>8.3.17.0</b>	Supported on the M I/O Aggregator.

## Filtering show Commands

To find specific information, display certain information only or begin the command output at the first instance of a regular expression or phrase, you can filter the display output of a `show` command.

When you execute a `show` command, and then enter a pipe ( `|` ), one of the following parameters, and a regular expression, the resulting output either excludes or includes those parameters.

**NOTE:** The Dell Networking OS accepts a space before or after the pipe, no space before or after the pipe, or any combination. For example: `Dell#command | grep TenGig|except regular-expression | find regular-expression`.

<b>except</b>	displays only the text that does not match the pattern (or regular expression)
<b>find</b>	searches for the first occurrence of a pattern
<b>grep</b>	displays text that matches a pattern.
<b>no-more</b>	does not paginate the display output
<b>save</b>	copies the output to a file for future use

The `grep` command option has an `ignore-case` sub-option that makes the search case-insensitive. For example, the commands:

- `show run | grep Ethernet` returns a search result with instances containing a capitalized “Ethernet,” such as interface TenGigabitEthernet 0/1.
- `show run | grep ethernet` does not return the search result above because it only searches for instances containing a non-capitalized “ethernet”.
- `show run | grep Ethernet ignore-case` returns instances containing both “Ethernet” and “ethernet”.

## Displaying All Output

To display the output all at once (not one screen at a time), use the `no-more` option after the pipe. This operation is similar to the `terminal length screen-length` command except that the `no-more` option affects the output of just the specified command. For example:

```
Dell#show running-config|no-more
```

## Filtering the Command Output Multiple Times

You can filter a single command output multiple times. To filter a command output multiple times, place the `save` option as the last filter. For example:

```
Dell# command | grep regular-expression | except regular-expression | grep other-regular-expression | find regular-expression | no-more | save
```

# Command Modes

To navigate and launch various CLI modes, use specific commands. Navigation to these modes is described in the following sections.

## EXEC Mode

When you initially log in to the switch, by default, you are logged in to EXEC mode. This mode allows you to view settings and enter EXEC Privilege mode, which is used to configure the device.

When you are in EXEC mode, the > prompt is displayed following the host name prompt, which is “Dell” by default. You can change the host name prompt using the `hostname` command.

 **NOTE:** Each mode prompt is preceded by the host name.

## EXEC Privilege Mode

The `enable` command accesses EXEC Privilege mode. If an administrator has configured an “Enable” password, you are prompted to enter it.

EXEC Privilege mode allows you to access all the commands accessible in EXEC mode, plus other commands, such as to clear address resolution protocol (ARP) entries and IP addresses. In addition, you can access CONFIGURATION mode to configure interfaces, routes and protocols on the switch. While you are logged in to EXEC Privilege mode, the # prompt displays.

## CONFIGURATION Mode

In EXEC Privilege mode, use the `configure` command to enter CONFIGURATION mode and configure routing protocols and access interfaces.

To enter CONFIGURATION mode:

1. Verify that you are logged in to EXEC Privilege mode.
2. Enter the `configure` command. The prompt changes to include (conf).

From this mode, you can enter INTERFACE mode by using the `interface` command.

## INTERFACE Mode

To configure interfaces or IP services on those interfaces, use INTERFACE mode. An interface can be physical (for example, a TenGigabit Ethernet port) or virtual (for example, the VLAN interface).

To enter INTERFACE mode:

1. Verify that you are logged in to CONFIGURATION mode.
2. Enter the `interface` command and then enter an interface type and interface number that is available on the switch.

The prompt changes to include the designated interface and slot/port number. For example:

Prompt	Interface Type
<b>Dell (conf-if-te-0/1) #</b>	Ten-Gigabit Ethernet interface then slot/port information
<b>Dell (conf-if-vl-1) #</b>	VLAN Interface then VLAN number (range 1–4094)
<b>Dell (conf-if-ma-0/0) #</b>	Management Ethernet interface then slot/port information
<b>Dell (conf-if-range) #</b>	Designated interface range (used for bulk configuration)

## LINE Mode

To configure the console or virtual terminal parameters, use LINE mode.

To enter LINE mode:

1. Verify that you are logged in to CONFIGURATION mode.
2. Enter the `line` command. Include the keywords `console` or `vt` and their line number available on the switch. The prompt changes to include `(config-line-console)` or `(config-line-vty)`.

You can exit this mode by using the `exit` command.

## MONITOR SESSION Mode

In CONFIGURATION mode, use the `monitor session` command to enter MONITOR SESSION mode and configure port monitoring.

To enter MONITOR SESSION mode:

1. Verify that you are logged in to CONFIGURATION mode.
2. Use the `monitor session` command. Include the monitor session ID. The prompt changes to include `(conf-mon-sess)`.

You can return to CONFIGURATION mode by using the `exit` command.

## PROTOCOL LLDP Mode

In CONFIGURATION mode, use the `protocol lldp` command to enter PROTOCOL LLDP mode and configure the LLDP protocol.

To enter PROTOCOL LLDP mode:

1. Verify that you are logged in to CONFIGURATION mode.
2. Enter the `protocol lldp` command. The prompt changes to include `Dell (config-lldp)`.

You can return to CONFIGURATION mode by using the `exit` command.

# File Management

This chapter contains commands needed to manage the configuration files and includes other file management commands.

## Topics:

- [boot system gateway](#)
- [boot system stack-unit](#)
- [cd](#)
- [copy](#)
- [copy running-config startup-config](#)
- [delete](#)
- [dir](#)
- [format flash](#)
- [HTTP Copy via CLI](#)
- [logging coredump stack-unit](#)
- [pwd](#)
- [rename](#)
- [restore factory-defaults](#)
- [show boot system](#)
- [show file](#)
- [show file-systems](#)
- [show os-version](#)
- [show running-config](#)
- [show version](#)
- [upgrade boot](#)
- [upgrade system](#)

## boot system gateway

Specify the IP address of the default next-hop gateway for the management subnet.

**Syntax** `boot system gateway ip-address`

**Parameters** *ip-address* Enter an IP address in dotted decimal format.

**Command Modes** CONFIGURATION

**Supported Modes** All Modes

Command History	Version	Description
	<b>9.4(0.0)</b>	Supported on the FN I/O Aggregator.
	<b>8.3.17.0</b>	Supported on the M I/O Aggregator.

**Usage Information** Saving the address to the startup configuration file preserves the address in NVRAM in case the startup configuration file is deleted.

# boot system stack-unit

Specify the location of the Dell Networking OS image to be used to boot the system.

<b>Syntax</b>	<code>boot system stack-unit &lt;0-5   all&gt; {default   primary   secondary}</code>	
<b>Parameters</b>	<b>0-5</b>	Enter the stack member unit identifier of the stack member.
	<b>all</b>	Enter the keyword <code>all</code> to set the primary, secondary, and default images for the system.
	<b>default</b>	Enter the keyword <code>default</code> to set the default image path for the system.
	<b>primary</b>	Enter the keyword <code>primary</code> to set the primary image path for the system.
	<b>secondary</b>	Enter the keyword <code>secondary</code> to set the secondary image path for the system.
<b>Command Modes</b>	CONFIGURATION	
<b>Supported Modes</b>	All Modes	
<b>Command History</b>	<b>Version</b>	<b>Description</b>
	<b>9.9(0.0)</b>	Introduced on the FN IOM.
	<b>8.3.17.0</b>	Supported on the M I/O Aggregator.
	<b>9.4(0.0)</b>	Supported on the FN I/O aggregator.
<b>Usage Information</b>	The system first attempts to load the image from the primary path. If it fails to boot, the system tries to load the image from the secondary path and if that also fails, the system loads the default image.	

## cd

Change to a different working directory.

<b>Syntax</b>	<code>cd <i>directory</i></code>	
<b>Parameters</b>	<b><i>directory</i></b>	(OPTIONAL) Enter one of the following: <ul style="list-style-type: none"><li>• <code>flash</code>: (internal Flash) or any sub-directory</li><li>• <code>usbflash</code>: (external Flash) or any sub-directory</li></ul>
<b>Command Modes</b>	EXEC Privilege	
<b>Supported Modes</b>	All Modes	
<b>Command History</b>	<b>Version</b>	<b>Description</b>
	<b>9.9(0.0)</b>	Introduced on the FN IOM.
	<b>9.4(0.0)</b>	Supported on the FN I/O Aggregator.
	<b>8.3.17.0</b>	Supported on the M I/O Aggregator.

## copy

Copy one file to another location. The Dell Networking OS supports IPv4 addressing for FTP, TFTP, and SCP (in the *hostip* field).

<b>Syntax</b>	<code>copy <i>source-file-url</i> <i>destination-file-url</i></code>	
<b>Parameters</b>	<b><i>file-url</i></b>	Enter the following location keywords and information:

- To copy a file from the internal FLASH, enter `flash://` then the filename.
- To copy the running configuration, enter the keywords `running-config`.
- To copy the startup configuration, enter the keywords `startup-config`.
- To copy a file on the external FLASH, enter `usbflash://` then the filename.

**Command Modes** EXEC Privilege

**Supported Modes** All Modes

Command History	Version	Description
	<b>9.9(0.0)</b>	Introduced on the FN IOM.
	<b>9.4(0.0)</b>	Supported on the FN I/O Aggregator.
	<b>8.3.17.0</b>	Supported on the M I/O Aggregator.

**Usage Information** The Dell Networking OS supports a maximum of 100 files, at the root directory level, on both the internal and external Flash.

The `usbflash` commands are supported. For a list of approved USB vendors, refer to the *Dell Networking OS Release Notes*.

When copying a file to a remote location (for example, using Secure Copy [SCP]), enter only the keywords and Dell Networking OS prompts you for the rest of the information.

**NOTE:** Dell Networking OS imposes a length limit on the password you create for performing the secure copy operation. Your password can be no longer than 32 characters.

For example, when using SCP, you can enter the `copy running-config scp:` command. The `running-config` is the source and the target is specified in the ensuing prompts. Dell Networking OS prompts you to enter any required information, as needed for the named destination — remote destination, destination filename, user ID and password, and so forth.

When you use the `copy running-config startup-config` command to copy the running configuration to the startup configuration file, Dell Networking OS creates a backup file on the internal flash of the startup configuration.

When you load the startup configuration or a configuration file from a network server such as TFTP to the running configuration, the configuration is added to the running configuration. This does not replace the existing running configuration. Commands in the configuration file has precedence over commands in the running configuration.

The Dell Networking OS supports copying the running-configuration to a TFTP server or to an FTP server:

- `copy running-config tftp:`
- `copy running-config ftp:`

**NOTE:** Dell Networking OS imposes a length limit on the password you create for accessing the FTP server. Your password can be no longer than 32 characters.

In the `copy scp: flash: example`, specifying SCP in the first position indicates that the target to specify in the ensuing prompts. Entering `flash:` in the second position means that the target is the internal Flash. In this example, the source is on a secure server running SSH, so you are prompted for the UDP port of the SSH server on the remote host.

**Example (running-config scp:)**

```
Dell#copy running-config scp:
Address or name of remote host []: 10.10.10.1
Port number of the server [22]: 99
Destination file name [startup-config]: old_running
User name to login remote host: sburgess
Password to login remote host:
Password to login remote host? dilling
```

### Example (copy scp:)

```
Dell#copy scp: flash:
Address or name of remote host []: 10.11.199.134
Port number of the server [22]: 99
Source file name []: test.cfg
User name to login remote host: admin
Password to login remote host:
Destination file name [test.cfg]: test1.cfg
```

### Related Commands

`cd` — Changes the working directory.

## copy running-config startup-config

Copy running configuration to the startup configuration.

**Syntax** `copy running-config startup-config {duplicate}`

**Command Modes** EXEC Privilege

**Supported Modes** All Modes

Command History	Version	Description
	<b>9.9(0.0)</b>	Introduced on the FN IOM.
	<b>9.4(0.0)</b>	Supported on the FN I/O Aggregator.
	<b>8.3.17.0</b>	Supported on the M I/O Aggregator.

**Usage Information** This command is useful for quickly making a change configuration on one chassis available on external flash to move it to another chassis.

## delete

Delete a file from the flash. After deletion, files cannot be restored.

**Syntax** `delete flash: ([flash://]filepath) usbflash ([usbflash://]filepath)`

**Parameters**

<b>flash-url</b>	Enter the following location and keywords: <ul style="list-style-type: none"><li>• For a file or directory on the internal Flash, enter <code>flash://</code> then the filename or directory name.</li><li>• For a file or directory on an external USB drive, enter <code>usbflash://</code> then the filename or directory name.</li></ul>
<b>no-confirm</b>	(OPTIONAL) Enter the keywords <code>no-confirm</code> to specify that the Dell Networking OS does not require user input for each file prior to deletion.

**Command Modes** EXEC Privilege

**Supported Modes** All Modes

Command History	Version	Description
	<b>9.9(0.0)</b>	Introduced on the FN IOM.
	<b>9.4(0.0)</b>	Supported on the FN I/O Aggregator.
	<b>8.3.17.0</b>	Supported on the M I/O Aggregator

# dir

Displays the files in a file system. The default is the current directory.

**Syntax** `dir [filename | directory name:]`

**Parameters**

**filename | directory name:** (OPTIONAL) Enter one of the following:

- For a file or directory on the internal Flash, enter `flash://` then the filename or directory name.
- For a file or directory on an external USB drive, enter `usbflash://` then the filename or directory name.

**Command Modes** EXEC Privilege

**Supported Modes** All Modes

Command History	Version	Description
	<b>9.9(0.0)</b>	Introduced on the FN IOM.
	<b>9.4(0.0)</b>	Supported on the FN I/O Aggregator.
	<b>8.3.17.0</b>	Supported on the M I/O Aggregator.

## Example

```
Dell#dir
Directory of flash:

 1  drwx  4096      Jan 01 1980 00:00:00 +00:00  .
 2  drwx  2048      Mar 06 2010 00:36:21 +00:00  ..
 3  drwx  4096      Feb 25 2010 23:32:50 +00:00  TRACE_LOG_DIR
 4  drwx  4096      Feb 25 2010 23:32:50 +00:00  CORE_DUMP_DIR
 5  d---  4096      Feb 25 2010 23:32:50 +00:00  ADMIN_DIR
 6  -rwx  720969768 Mar 05 2010 03:25:40 +00:00  6gb
 7  -rwx  4260       Mar 03 2010 22:04:50 +00:00  prem-23-5-12
 8  -rwx  31969685  Mar 05 2010 17:56:26 +00:00
DellS-XL-8-3-16-148.bin
 9  -rwx  3951       Mar 06 2010 00:36:18 +00:00  startup-config

flash: 2143281152 bytes total (1389801472 bytes free)
Dell#
```

**Related Commands** `cd` — Changes the working directory.

# format flash

Erase all existing files and reformat the filesystem in the internal flash memory. After the filesystem is formatted, files cannot be restored.

**Syntax** `format {flash: | usbflash:}`

**Defaults** **flash memory**

**Command Modes** EXEC Privilege

**Supported Modes** All Modes

Command History	Version	Description
	<b>9.9(0.0)</b>	Introduced on the FN IOM.
	<b>9.4(0.0)</b>	Supported on the FN I/O Aggregator.
	<b>8.3.17.0</b>	Supported on the M I/O Aggregator.



## Usage Information

You must include the colon (:) when entering this command.

**CAUTION:** This command deletes all files, including the startup configuration file. So, after executing this command, consider saving the running config as the startup config (use the `write memory` command or `copy run start` command).

## Related Commands

`copy` – copies the current configuration to either the startup-configuration file or the terminal.

`show file` – displays the contents of a text file in the local filesystem.

`show file-systems` – displays information about the file systems on the system.

# HTTP Copy via CLI

Copy one file to another location. Dell Networking OS supports IPv4 and IPv6 addressing for FTP, TFTP, and SCP (in the *hostip* field).

## Syntax

```
copy http://10.16.206.77/sample_file flash://sample_filecopy flash://sample_file http://10.16.206.77/sample_file
```

You can copy from the server to the switch and vice-versa.

## Parameters

<b>copy http:</b>	Address or name of remote host []: 10.16.206.77
<b>flash:</b>	Port number of the server [80]:
	Source file name []: sample_file
	User name to login remote host: x
	Password to login remote host:
	Destination file name [sample_file]:

## Defaults

None.

## Command Modes

EXEC

## Supported Modes

All Modes

## Command History

Version	Description
<b>9.9(0.0)</b>	Introduced on the FN IOM.
<b>9.4(0.0)</b>	Introduced on the FN I/O Aggregator.
<b>9.3(0.1)</b>	Introduced on the M I/O Aggregator.

## Example

```
copy http://admin:admin123@10.16.206.77/sample_file flash://sample_file
```

## Related Commands

`copy ftp:flash`

Copy files from FTP server to switch

# logging coredump stack-unit

Enable the coredump.

## Syntax

```
logging coredump stack-unit all
```

## Command Modes

CONFIGURATION

## Supported Modes

All Modes

<b>Command History</b>	<table border="0"> <thead> <tr> <th style="text-align: left;"><b>Version</b></th> <th style="text-align: left;"><b>Description</b></th> </tr> </thead> <tbody> <tr> <td><b>9.9(0.0)</b></td> <td>Introduced on the FN IOM.</td> </tr> <tr> <td><b>9.4(0.0)</b></td> <td>Supported on the FN I/O Aggregator.</td> </tr> <tr> <td><b>8.3.17.0</b></td> <td>Supported on the M I/O Aggregator.</td> </tr> </tbody> </table>	<b>Version</b>	<b>Description</b>	<b>9.9(0.0)</b>	Introduced on the FN IOM.	<b>9.4(0.0)</b>	Supported on the FN I/O Aggregator.	<b>8.3.17.0</b>	Supported on the M I/O Aggregator.
<b>Version</b>	<b>Description</b>								
<b>9.9(0.0)</b>	Introduced on the FN IOM.								
<b>9.4(0.0)</b>	Supported on the FN I/O Aggregator.								
<b>8.3.17.0</b>	Supported on the M I/O Aggregator.								
<b>Usage Information</b>	The Kernel core dump can be large and may take up to five to 30 minutes to upload. The Dell Networking OS does not overwrite application core dumps so delete them as necessary to conserve space on the flash; if the flash is out of memory, the coredump is aborted. The Dell Networking OS completes the coredump process and waits until the upload is complete before rebooting the system.								

## pwd

Display the current working directory.

<b>Syntax</b>	<code>pwd</code>
<b>Command Modes</b>	EXEC Privilege
<b>Supported Modes</b>	All Modes

<b>Command History</b>	<table border="0"> <thead> <tr> <th style="text-align: left;"><b>Version</b></th> <th style="text-align: left;"><b>Description</b></th> </tr> </thead> <tbody> <tr> <td><b>9.9(0.0)</b></td> <td>Introduced on the FN IOM.</td> </tr> <tr> <td><b>9.4(0.0)</b></td> <td>Supported on the FN I/O Aggregator.</td> </tr> <tr> <td><b>8.3.17.0</b></td> <td>Supported on the M I/O Aggregator.</td> </tr> </tbody> </table>	<b>Version</b>	<b>Description</b>	<b>9.9(0.0)</b>	Introduced on the FN IOM.	<b>9.4(0.0)</b>	Supported on the FN I/O Aggregator.	<b>8.3.17.0</b>	Supported on the M I/O Aggregator.
<b>Version</b>	<b>Description</b>								
<b>9.9(0.0)</b>	Introduced on the FN IOM.								
<b>9.4(0.0)</b>	Supported on the FN I/O Aggregator.								
<b>8.3.17.0</b>	Supported on the M I/O Aggregator.								

### Example

```
Dell#pwd
flash:
Dell#
```

**Related Commands**     `cd` – changes the directory.

## rename

Rename a file in the local file system.

**Syntax**     `rename url url`

**Parameters**     *url*

Enter the following keywords and a filename:

- For a file on the internal Flash, enter `flash://` then the filename.
- For a file on an external USB drive, enter `usbflash://` then the filename.

<b>Command Modes</b>	EXEC Privilege
<b>Supported Modes</b>	All Modes

<b>Command History</b>	<table border="0"> <thead> <tr> <th style="text-align: left;"><b>Version</b></th> <th style="text-align: left;"><b>Description</b></th> </tr> </thead> <tbody> <tr> <td><b>9.9(0.0)</b></td> <td>Introduced on the FN IOM.</td> </tr> <tr> <td><b>9.4(0.0)</b></td> <td>Supported on the FN I/O Aggregator.</td> </tr> <tr> <td><b>8.3.17.0</b></td> <td>Supported on the M I/O Aggregator.</td> </tr> </tbody> </table>	<b>Version</b>	<b>Description</b>	<b>9.9(0.0)</b>	Introduced on the FN IOM.	<b>9.4(0.0)</b>	Supported on the FN I/O Aggregator.	<b>8.3.17.0</b>	Supported on the M I/O Aggregator.
<b>Version</b>	<b>Description</b>								
<b>9.9(0.0)</b>	Introduced on the FN IOM.								
<b>9.4(0.0)</b>	Supported on the FN I/O Aggregator.								
<b>8.3.17.0</b>	Supported on the M I/O Aggregator.								

# restore factory-defaults

Restore factory defaults.

**Syntax** `restore factory-defaults stack-unit id {clear-all | nvram}`

**Parameters**

- factory-defaults** Return the system to its factory default mode.
- id*** Enter the stack member unit identifier to restore the mentioned stack-unit. The range is from 0 to 6. Enter the keyword `all` to restore all units in the stack.
- clear-all** Enter the keywords `clear-all` to reset the NvRAM and the system startup configuration.
- nvram** Enter the keyword `nvram` to reset the NvRAM only.

**Command Modes** EXEC Privilege

**Supported Modes** All Modes

Command History	Version	Description
	<b>9.9(0.0)</b>	Introduced on the FN IOM.
	<b>9.4(0.0)</b>	Supported on the FN I/O aggregator.
	<b>8.3.17.0</b>	Supported on the M I/O Aggregator.

**Usage Information** Restoring factory defaults deletes the existing startup configuration and all persistent settings (stacking, fanout, and so forth).

When restoring all units in a stack, all the units in the stack are placed into stand-alone mode.

When restoring a single unit in a stack, that unit placed in stand-alone mode. No other units in the stack are affected.

When restoring units in stand-alone mode, the units remain in stand-alone mode after the restoration. After the restore is complete, the units power cycle immediately.

 **CAUTION: There is no undo for this command.**

## Example

```
Dell#restore factory-defaults stack-unit 0 clear-all

*****
*Warning - Restoring factory defaults will delete the existing*
*startup-config and resets all persistent settings (stacking,*
*fanout, etc.) and boot environment variables (boot config, console*
*baud rate, management interface settings, etc.)*
*After restoration the unit(s) will be powercycled immediately.*
*Proceed with caution !*
*****

Proceed with factory settings? Confirm [yes/no]:yes

-- Restore status --
Unit   Nvram    Config   Bootvar
-----
  0     Success  Success  Success
Dell#
```

## Example (NvRAM, all)

```
Dell#restore factory-defaults stack-unit all nvram
*****
*Warning - Restoring factory defaults will delete the existing*
*persistent settings (stacking, fanout, etc.)*
*All the units in the stack will be split into standalone units.*
*After restoration the unit(s) will be powercycled immediately.*
*Proceed with caution ! *
*****
```

```

Proceed with factory settings? Confirm [yes/no]:yes
-- Restore status --
Unit Nvram      Config
-----
0      Success
1      Success
2      Success
3      Not present
4      Not present
5      Not present
Power-cycling the unit(s).
Dell#

```

**Example  
(NvRAM, single  
unit)**

```

Dell#restore factory-defaults stack-unit 1 nvram
*****
*Warning - Restoring factory defaults will delete the existing *
*persistent settings (stacking, fanout, etc.) *
*After restoration the unit(s) will be powercycled immediately. *
*Proceed with caution ! *
*****
Proceed with factory settings? Confirm [yes/no]:yes
-- Restore status --
Unit Nvram      Config
-----
1      Success
Power-cycling the unit(s).
Dell#

```

## show boot system

Displays information about boot images currently configured on the system.

**Syntax** `show boot system stack-unit {0-5 | all}`

**Parameters**

- 0-5** Enter this information to display the boot image information of only the entered stack-unit.
- all** Enter the keyword `all` to display the boot image information of all the stack-units in the stack.

**Defaults** none

**Command Modes**

- EXEC
- EXEC Privilege

**Supported Modes** All Modes

Command History	Version	Description
	<b>9.9(0.0)</b>	Introduced on the FN IOM.
	<b>9.4(0.0)</b>	Supported on the FN I/O Aggregator.
	<b>8.3.17.0</b>	Supported on the M I/O Aggregator.

**Example**

```

Dell#show boot system stack-unit all
Current system image information in the system:
=====
Type      Boot Type      A      B
-----
Stack-unit 0 is not present.
Stack-unit 1 DOWNLOAD BOOT 9-1-0-218      9-1-0-202
Stack-unit 2 is not present.
Stack-unit 3 is not present.

```

```
Stack-unit 4 is not present.
Stack-unit 5 is not present.
```

## show file

Displays contents of a text file in the local filesystem.

**Syntax** `show file url`

**Parameters** *url* Enter one of the following:

- For a file on the internal Flash, enter `flash://` then the filename.
- For a file on the external Flash, enter `usbflash://` then the filename.

**Command Modes** EXEC Privilege

**Supported Modes** All Modes

Command History	Version	Description
	<b>9.9(0.0)</b>	Introduced on the FN IOM.
	<b>9.4(0.0)</b>	Supported on the FN I/O Aggregator.
	<b>8.3.17.0</b>	Supported on the M I/O Aggregator.

### Example

```
Dell#show file flash://startup-config
! Version E8-3-17-38
boot system stack-unit 1 primary tftp://10.11.9.21/dv-m1000e-2-b2
boot system stack-unit 1 default system: A:
boot system gateway 10.11.209.62
!
hostname FTOS
--More--
Dell#
```

**Related Commands** [format flash](#) — erases all the existing files and reformats the filesystem in the internal flash memory.  
[show file-systems](#) — displays information about the file systems on the system.

## show file-systems

Displays information about the file systems on the system.

**Syntax** `show file-systems`

**Command Modes** EXEC Privilege

**Supported Modes** All Modes

Command History	Version	Description
	<b>9.9(0.0)</b>	Introduced on the FN IOM.
	<b>9.4(0.0)</b>	Supported on the FN I/O Aggregator.
	<b>8.3.17.0</b>	Supported on the M I/O Aggregator.

### Example

```
Dell#show file-systems
Size(b)      Free(b)      Feature Type      Flags Prefixes
2143281152   836874240   FAT32  USERFLASH  rw  flash:
-            -            -      network    rw  ftp:
-            -            -      network    rw  tftp:
```

```
Dell# - - - network rw scp:
```

#### Command Fields

Field	Description
<b>size(b)</b>	Lists the size in bytes of the storage location. If the location is remote, no size is listed.
<b>Free(b)</b>	Lists the available size in bytes of the storage location. If the location is remote, no size is listed.
<b>Feature</b>	Displays the formatted DOS version of the device.
<b>Type</b>	Displays the type of storage. If the location is remote, the word <code>network</code> is listed.
<b>Flags</b>	Displays the access available to the storage location. The following letters indicate the level of access: <ul style="list-style-type: none"><li>• r = read access</li><li>• w = write access</li></ul>
<b>Prefixes</b>	Displays the name of the storage location.

#### Related Commands

[format flash](#) – erases all the existing files and reformats the filesystem in the internal flash memory.  
[show file](#) – displays the contents of a text file in the local filesystem.

## show os-version

Displays the release and software image version information of the image file specified.

**Syntax** `show os-version [file-url]`

**Parameters**

**file-url** (OPTIONAL) Enter the following location keywords and information:

- For a file on the internal Flash, enter `flash://` then the filename.
- For a file on an FTP server, enter `ftp://user:password@hostip/filepath`.
- For a file on a TFTP server, enter `tftp://hostip/filepath`.
- For a file on the external Flash, enter `usbflash://filepath` then the filename.

**Defaults** none

**Command Modes** EXEC Privilege

**Supported Modes** All Modes

#### Command History

Version	Description
<b>9.9(0.0)</b>	Introduced on the FN IOM.
<b>9.4(0.0)</b>	Supported on the FN I/O Aggregator.
<b>8.3.17.0</b>	Supported on the M I/O Aggregator.

#### Usage Information

 **NOTE:** A filepath that contains a dot ( `.` ) is not supported.

#### Example

```
Dell#show os-version

RELEASE IMAGE INFORMATION :
-----
Platform          Version          Size             ReleaseTime
IOM-Series: XL    8-3-17-38       31603078        Jul 19 2012 06:02:28
```

```

TARGET IMAGE INFORMATION :
-----
Type           Version           Target      checksum
runtime        8-3-17-38         Control Processor  passed

CPLD IMAGE INFORMATION :
-----
Card           CPLD Name      Version
Stack-unit 1   IOM SYSTEM CPLD  6
Dell#

```

## show running-config

Displays the current configuration and display changes from the default values.

**Syntax** `show running-config [entity] [configured] [status]`

**Parameters** **entity** (OPTIONAL) To display that entity's current (non-default) configuration, enter one of the following keywords:

 **NOTE:** If you did not configure anything for that entity, nothing displays and the prompt returns.

<b>boot</b>	for the current boot configuration
<b>ftp</b>	for the current FTP configuration
<b>igmp</b>	for the current IGMP configuration
<b>interface</b>	for the current interface configuration
<b>line</b>	for the current line configuration
<b>lldp</b>	for the current lldp configuration
<b>logging</b>	for the current logging configuration
<b>management-route</b>	for the current Management port forwarding configuration
<b>monitor</b>	for the current Monitor configuration
<b>snmp</b>	for the current SNMP configuration
<b>uplink-state-group</b>	for the uplink state group configuration
<b>users</b>	for the current users configuration

**configured** (OPTIONAL) Enter the keyword `configured` to display line card interfaces with non-default configurations only.

**status** (OPTIONAL) Enter the keyword `status` to display the checksum for the running configuration and the start-up configuration.

**Command Modes** EXEC Privilege

**Supported Modes** All Modes

Command History	Version	Description
	<b>9.9(0.0)</b>	Introduced on the FN IOM.
	<b>9.4(0.0)</b>	Supported on the FN I/O aggregator.
	<b>8.3.17.0</b>	Supported on the M I/O Aggregator.

**Example**

```

Dell#show running-config
Current Configuration ...

```

```

! Version 9-4(0-180)
!
boot system stack-unit 0 primary tftp://10.11.8.12/dv-ci-stomp-tc-1-a1
!
redundancy auto-synchronize full
!
hostname Dell
...

```

### Example

```

Dell#show running-config status

running-config bytes 5063, checksum 0xF6F801AC
startup-config bytes 4835, checksum 0x764D3787
Dell#

```

### Example

```

Dell#sh running-config interface vlan
!
interface Vlan 1
 ip address dhcp
 mtu 2500
 no shutdown
Dell#

```

### Usage Information

The status option allows you to display the size and checksum of the running configuration and the startup configuration.

## show version

Displays the current Dell Networking OS version information on the system.

**Syntax** show version

**Command Modes** EXEC Privilege

**Supported Modes** All Modes

### Command History

Version	Description
9.9(0.0)	Introduced on the FN IOM.
9.4(0.0)	Supported on the FN I/O Aggregator.
8.3.17.0	Supported on the M I/O Aggregator.

### Example

```

Dell#show version
Dell Force10 Real Time Operating System Software
Dell Force10 Operating System Version: 1.0
Dell Force10 Application Software Version: E8-3-17-38
Copyright (c) 1999-2012 by Dell Inc. All Rights Reserved.
Build Time: Thu Jul 19 05:59:59 PDT 2012
Build Path: /sites/sjc/work/swsystems01-2/ravisubramani/
ravis-8317/SW/SRC/
Cp_src/Tacacs
FTOS uptime is 4 day(s), 4 hour(s), 3 minute(s)
System image file is "dv-m1000e-2-b2" System Type: I/O-Aggregator
Control Processor: MIPS RMI XLP with 2147483648 bytes of memory.

256M bytes of boot flash memory.

1 34-port GE/TE (XL)
56 Ten GigabitEthernet/IEEE 802.3 interface(s)

```



Command Fields	Lines	Description
	<b>Beginning With</b>	
	<b>Dell Force10 Network...</b>	Name of the operating system
	<b>Dell Force10 Operating...</b>	OS version number
	<b>Dell Force10 Application...</b>	Software version
	<b>Copyright (c)...</b>	Copyright information
	<b>Build Time...</b>	Software build's date stamp
	<b>Build Path...</b>	Location of the software build files loaded on the system
	<b>Dell Force10 uptime is...</b>	Amount of time the system has been up
	<b>System image...</b>	Image file name
	<b>Chassis Type:</b>	System type (M I/O Aggregator)
	<b>Control Processor:...</b>	Control processor information and amount of memory on processor
	<b>256M bytes...</b>	Amount of boot flash memory on the system
	<b>1 34 Port</b>	Hardware configuration of the system, including the number and type of physical interfaces available

## upgrade boot

Upgrade the bootflash image or bootselector image.

**Syntax** `upgrade boot {all | bootflash-image | bootselector-image} stack-unit {0-5 | all} {booted | flash: | ftp: | tftp: | usbflash:} (A: | B:)`

Parameters	
<b>all</b>	Enter the keyword <code>all</code> to change both the bootflash and bootselector images.
<b>bootflash-image</b>	Enter the keywords <code>bootflash-image</code> to change the bootflash image.
<b>bootselector-image</b>	Enter the keywords <code>bootselector-image</code> to change the bootselector image.
<b>0-5</b>	Enter the keyword <code>0-5</code> to upgrade only the mentioned stack-unit.
<b>all</b>	Enter the keyword <code>all</code> to upgrade all the member stack-units.
<b>booted</b>	Enter the keyword <code>booted</code> to upgrade from the current image in the M I/O Aggregator.
<b>ftp:</b>	After entering the keyword <code>ftp:</code> , you can either follow it with the location of the source file in this form: <code>//userid:password@hostip/filepath</code> or press Enter to launch a prompt sequence.
<b>tftp:</b>	After entering the keyword <code>tftp:</code> , you can either follow it with the location of the source file in this form: <code>//hostlocation/filepath</code> or press Enter to launch a prompt sequence.
<b>flash:</b>	After entering the keyword <code>flash:</code> , you can either follow it with the location of the source file in this form: <code>//filepath</code> or press Enter to launch a prompt sequence.

**usbflash:** After entering the keyword `usbflash:`, you can either follow it with the location of the source file in this form: `//filepath` or press Enter to launch a prompt sequence.

**A:** Enter this keyword to upgrade the bootflash partition A.

**B:** Enter this keyword to upgrade the bootflash partition B.

**Defaults** none

**Command Modes** EXEC Privilege

**Supported Modes** All Modes

Command History	Version	Description
	<b>9.9(0.0)</b>	Introduced on the FN IOM.
	<b>9.4(0.0)</b>	Supported on the FN I/O Aggregator.
	<b>8.3.17.0</b>	Supported on the M I/O Aggregator.

**Usage Information** You must reload the Dell Networking OS after executing this command.

**Example**

```
Dell#upgrade boot ?
all Upgrade both boot flash image and selector image
bootflash-image Upgrade boot flash image
bootselector-image Upgrade boot selector image
Dell#
```

## upgrade system

Upgrade the bootflash image or system image.

**Syntax** `upgrade system {flash: | ftp: | scp: | tftp: | usbflash: | stack-unit {0-5 | all} {A: | B:}}`

**Parameters**

- 0-5** Enter the keyword 0-5 to upgrade only the mentioned stack-unit.
- all** Enter the keyword `all` to upgrade all the member units of the stack.
- ftp** After entering the keyword `ftp` you can either follow it with the location of the source file in this form: `//userid:password@hostip/filepath`, or press Enter to launch a prompt sequence.
- scp** After entering the keyword `scp` you can either follow it with the location of the source file in this form: `//userid:password@hostip/filepath`, or press Enter to launch a prompt sequence.
- tftp** After entering the keyword `tftp` you can either follow it with the location of the source file in this form: `//hostlocation/filepath`, or press Enter to launch a prompt sequence.
- flash** After entering the keyword `flash` you can either follow it with the location of the source file in this form: `//filepath`, or press Enter to launch a prompt sequence.
- usbflash** After entering the keyword `usbflash` you can either follow it with the location of the source file in this form: `//filepath`, or press Enter to launch a prompt sequence.
- A:** Enter this keyword to upgrade the bootflash partition A.
- B:** Enter this keyword to upgrade the bootflash partition B.

**Defaults** none

**Command Modes** EXEC Privilege

**Supported Modes** All Modes

**Command History**

<b>Version</b>	<b>Description</b>
<b>9.9(0.0)</b>	Introduced on the FN IOM.
<b>9.4(0.0)</b>	Supported on the FN I/O Aggregator.
<b>8.3.17.0</b>	Supported on the M I/O Aggregator.

**Usage Information**

You must reload Dell Networking OS after executing this command. Use the command `upgrade system stack-unit` to copy Dell Networking OS from the management unit to one or more stack members.

**Example**

```
Dell#upgrade system ?
flash:          Copy from flash file system (flash://filepath)
ftp:            Copy from remote file system, IPv4 or IPv6, (ftp://
/userid:password@hostip/filepath)
scp:            Copy from remote file system, IPv4 or IPv6, (scp://
/userid:password@hostip/filepath)
stack-unit Sync image to the stack-unit
tftp:           Copy from remote file system, IPv4 or IPv6, (tftp://
/hostip/filepath)
usbflash:       Copy from usbflash file system (usbflash://
filepath)
Dell#
```

# Control and Monitoring

This chapter describes control and monitoring for the I/O Aggregator.

## Topics:

- asset-tag
- clear alarms
- clear command history
- configure
- debug cpu-traffic-stats
- debug ifm trace-flags
- disable
- enable
- end
- exit
- feature unique-name
- ftp-server enable
- ftp-server topdir
- ftp-server username
- hostname
- http-server
- ip telnet server enable
- ip telnet source-interface
- line
- ping
- reload
- service timestamps
- show alarms
- show command-history
- show configuration lock
- show cpu-traffic-stats
- show debugging
- show diag
- show environment
- show inventory
- show memory
- show processes cpu
- show processes ipc flow-control
- show processes memory
- show reset-reason
- show revision
- show server-interfaces
- show system
- show tech-support
- show uplink brief
- show util-threshold cpu
- show util-threshold memory
- ssh-peer-stack-unit
- telnet
- telnet-peer-stack-unit
- terminal length

- [terminal monitor](#)
- [terminal xml](#)
- [trace route](#)
- [undebbug all](#)
- [write](#)

## asset-tag

Assign and store a unique asset-tag to the stack member.

**Syntax** `asset-tag stack-unit unit id Asset-tag ID`  
 To remove the asset tag, use the `no stack-unit unit-id Asset-tag ID` command.

**Parameters**

**stack-unit *unit-id*** Enter the keywords `stack-unit` then the `unit-id` to assign a tag to the specific member. The range is from 0 to 5.

**Asset-tag ID** Enter a unique asset-tag ID to assign to the stack member. This option accepts a maximum of 10 characters, including all special characters except double quotes. To include a space in the asset-tag, enter a space within double quotes.

**Defaults** No asset-tag is assigned.

**Command Modes** EXEC Privilege

**Supported Modes** All Modes

Command History	Version	Description
	<b>9.9(0.0)</b>	Introduced on the FN IOM.
	<b>9.4(0.0)</b>	Supported on the FN I/O Aggregator.
	<b>9.2(0.0)</b>	Introduced on the M I/O Aggregator.

**Related Commands** [show system](#)— Displays the current status of all stack members or a specific member.

## clear alarms

Clear the alarms on the system.

**Syntax** `clear alarms`

**Command Modes** EXEC Privilege

**Supported Modes** All Modes

Command History	Version	Description
	<b>9.9(0.0)</b>	Introduced on the FN IOM.
	<b>9.4(0.0)</b>	Supported on the FN I/O Aggregator.
	<b>8.3.17.0</b>	Supported on the M I/O Aggregator.

**Usage Information** This command clears alarms that are no longer active. If an alarm situation is still active, it is seen in the system output.

# clear command history

Clear the command history log.

**Syntax** `clear command history`

**Command Modes** EXEC Privilege

**Supported Modes** All Modes

Command History	Version	Description
	<b>9.9(0.0)</b>	Introduced on the FN IOM.
	<b>9.4(0.0)</b>	Supported on the FN I/O Aggregator.
	<b>8.3.17.0</b>	Supported on the M I/O Aggregator.

**Related Commands** [show command-history](#)— displays a buffered log of all the commands all users enter along with a time stamp.

# configure

Enter CONFIGURATION mode from EXEC Privilege mode.

**Syntax** `configure [terminal]`

**Parameters** **terminal** (OPTIONAL) Enter the keyword `terminal` to specify that you are configuring from the terminal.

**Command Modes** EXEC Privilege

**Supported Modes** All Modes

Command History	Version	Description
	<b>9.9(0.0)</b>	Introduced on the IOM.
	<b>9.4(0.0)</b>	Supported on the FN I/O Aggregator.
	<b>8.3.17.0</b>	Supported on the M I/O Aggregator.

**Example**

```
Dell#configure
Dell(conf)#
```

# debug cpu-traffic-stats

Enable the collection of computer processor unit (CPU) traffic statistics.

**Syntax** `debug cpu-traffic-stats`

**Defaults** Disabled

**Command Modes** EXEC Privilege

**Supported Modes** All Modes

Command History	Version	Description
	<b>9.9(0.0)</b>	Introduced on the FN IOM.
	<b>9.4(0.0)</b>	Supported on the FN I/O Aggregator.

Version	Description
8.3.17.0	Supported on the M I/O Aggregator.

**Usage Information**

This command enables (and disables) the collection of CPU traffic statistics from the time this command is executed (not from system boot). However, excessive traffic a CPU receives automatically triggers (turn on) the collection of CPU traffic statistics.

To view the traffic statistics, use the `show cpu-traffic-stats` command.

If the CPU receives excessive traffic, traffic is rate controlled.

**NOTE:** You must enable this command before the `show cpu-traffic-stats` command displays traffic statistics. Dell Networking recommends disabling debugging (`no debug cpu-traffic-stats`) after troubleshooting is complete.

**Related Commands**

`show cpu-traffic-stats`— displays the cpu traffic statistics.

## debug ifm trace-flags

Turn on the IFM internal trace-flags.

**Syntax** `debug ifm trace-flags trace-flags`  
 To disable this command, use the `no debug ifm trace-flags` command.

**Parameters** *trace-flags* Enter a hexadecimal number representing the trace-flag.

**Defaults** None

**Command Modes** EXEC Privilege

**Supported Modes** All Modes

**Command History**

Version	Description
---------	-------------

9.9(0.0)	Introduced on the FN IOM.
9.4(0.0)	Supported on the FN I/O Aggregator.
8.3.17.0	Supported on the M I/O Aggregator.

**NOTE:** Use this command only when you are working directly with a technical support representative to troubleshoot a problem. Do not use this command unless a technical support representative instructs you to do so.

## disable

Return to EXEC mode.

**Syntax** `disable [level]`

**Parameters** *level* (OPTIONAL) Enter a number for a privilege level of the Dell Networking OS. The range is from 0 to 15. The default is **1**.

**Defaults** **1**

**Command Modes** EXEC Privilege

**Supported Modes** All Modes

Command History	Version	Description
	<b>9.9(0.0)</b>	Introduced on the FN IOM.
	<b>9.4(0.0)</b>	Supported on the FN I/O Aggregator.
	<b>8.3.17.0</b>	Supported on the M I/O Aggregator.

## enable

Enter EXEC Privilege mode or any other privilege level configured. After entering this command, you may need to enter a password.

**Syntax** `enable [level]`

**Parameters** *level* (OPTIONAL) Enter a number for a privilege level of the Dell Networking OS. The range is from 0 to 15. The default is **15**.

**Defaults** **15**

**Command Modes** EXEC

**Supported Modes** All Modes

Command History	Version	Description
	<b>9.9(0.0)</b>	Introduced on the FN IOM.
	<b>9.4(0.0)</b>	Supported on the FN I/O Aggregator.
	<b>8.3.17.0</b>	Supported on the M I/O Aggregator.

**Usage Information** Users entering EXEC Privilege mode or any other configured privilege level can access configuration commands. To protect against unauthorized access, use the `enable password` command to configure a password for the `enable` command at a specific privilege level. If no privilege level is specified, the default is privilege level **15**.

**Related Commands** [enable password](#) — configures a password for the `enable` command and to access a privilege level.

## end

Return to EXEC Privilege mode from other command modes (for example, CONFIGURATION mode).

**Syntax** `end`

**Command Modes**

- CONFIGURATION
- LINE
- INTERFACE
- MONITOR SESSION
- PROTOCOL LLDP

**Supported Modes** All Modes

Command History	Version	Description
	<b>9.9(0.0)</b>	Introduced on the FN IOM.
	<b>9.4(0.0)</b>	Supported on the FN I/O Aggregator.
	<b>8.3.17.0</b>	Supported on the M I/O Aggregator.

**Related Commands** [exit](#)— returns to the lower command mode.



# exit

Return to the lower command mode.

**Syntax** `exit`

- Command Modes**
- EXEC Privilege
  - CONFIGURATION
  - LINE
  - INTERFACE
  - PROTOCOL LLDP

**Supported Modes** All Modes

Command History	Version	Description
	<b>9.9(0.0)</b>	Introduced on the FN IOM.
	<b>9.4(0.0)</b>	Supported on the FN I/O Aggregator.
	<b>8.3.17.0</b>	Supported on the M I/O Aggregator.

**Related Commands** [end](#) — returns to EXEC Privilege mode.

# feature unique-name

Set a unique host name for the system.

**Syntax** `feature unique-name`

**Defaults** None

**Command Modes** CONFIGURATION

- Supported Modes**
- Standalone
  - VLT
  - Stacking
  - PMUX
  - STOMP Full Switch

Command History	Version	Description
	<b>9.10(0.0)</b>	Introduced on the M I/O Aggregator, the FN IOM and MXL.

**Usage Information** If you use the `feature unique-name` command, the system generates a host name using the platform type and system serial number. It overwrites any existing host name configured on the system using the `hostname` command. The `feature unique-name` command is also added to the running configuration.

If you disable the feature using the `no feature unique-name` command, the system reverts to the default host name of `Dell`.

If you use the `hostname` or the `no hostname` command after enabling the `feature unique-name` command, the system displays an error message stating that the `feature unique-name` is already enabled and provides an option to disable it.

**Related Commands** [hostname](#)

# ftp-server enable

Enable FTP server functions on the system.

- Syntax** `ftp-server enable`
- Defaults** Disabled
- Command Modes** CONFIGURATION
- Supported Modes** All Modes

Command History	Version	Description
	<b>9.9(0.0)</b>	Introduced on the FN IOM.
	<b>9.4(0.0)</b>	Supported on the FN I/O Aggregator.
	<b>8.3.17.0</b>	Supported on the M I/O Aggregator.

## Example

```
morpheus% ftp 10.31.1.111
Connected to 10.31.1.111.
220 FTOS (1.0) FTP server ready
Name (10.31.1.111:dch): dch
331 Password required
Password:
230 User logged in
ftp> pwd
257 Current directory is "flash:"
ftp> dir
200 Port set okay
150 Opening ASCII mode data connection
size  date           time name
-----
 512  Jul-20-2004  18:15:00  tgting
 512  Jul-20-2004  18:15:00  diagnostic
 512  Jul-20-2004  18:15:00  other
 512  Jul-20-2004  18:15:00  tgt
226 Transfer complete
329 bytes received in 0.018 seconds (17.95 Kbytes/s)
ftp>
```

- Related Commands** [ftp-server topdir](#)— sets the directory to be used for incoming FTP connections.
- [ftp-server username](#)— sets a username and password for incoming FTP connections.

# ftp-server topdir

Specify the top-level directory to be accessed when an incoming FTP connection request is made.

- Syntax** `ftp-server topdir directory`
- Parameters** *directory* Enter the directory path.
- Defaults** The internal flash is the default directory.
- Command Modes** CONFIGURATION
- Supported Modes** All Modes

Command History	Version	Description
	<b>9.9(0.0)</b>	Introduced on the FN IOM.
	<b>9.4(0.0)</b>	Supported on the FN I/O Aggregator.
	<b>8.3.17.0</b>	Supported on the M I/O Aggregator.

**Usage Information**

After you enable FTP server functions with the `ftp-server enable` command, Dell Networking recommends specifying a top-level directory path. Without a top-level directory path specified, the Dell Networking OS directs users to the flash directory when logging in to the FTP server.

**Related Commands**

[ftp-server enable](#) — enables FTP server functions on the M I/O Aggregator.

[ftp-server username](#) — sets a username and password for incoming FTP connections to the M I/O Aggregator.

## ftp-server username

Create a user name and associated password for incoming FTP server sessions.

**Syntax**

```
ftp-server username username password [encryption-type] password
```

**Parameters**

- |  |   |
|--|---|
| <b><i>username</i></b>                           | Enter a text string up to 40 characters long as the user name.  |
| <b><i>password</i></b><br><b><i>password</i></b> | Enter the keyword <code>password</code> then a string up to 40 characters long as the password. Without specifying an encryption type, the password is unencrypted.   |
| <b><i>encryption-type</i></b>                    | (OPTIONAL) After the keyword <code>password</code> , enter one of the following numbers: <ul style="list-style-type: none"><li>• 0 (zero) for an unencrypted (clear text) password</li><li>• 7 (seven) for a hidden text password</li></ul> |

**Defaults**

Not enabled.

**Command Modes**

CONFIGURATION

**Supported Modes**

All Modes

**Command History**

Version	Description
9.9(0.0)	Introduced on the FN IOM.
9.4(0.0)	Supported on the FN I/O Aggregator.
8.3.17.0	Supported on the M I/O Aggregator.

## hostname

Set the host name of the system.

**Syntax**

```
hostname name
```

**Parameters**

- |                    |  |
|--------------------|--|
| <b><i>name</i></b> | Enter a text string, up to 32 characters long. |
|--------------------|--|

**Defaults**

Dell Networking Operating System (OS)

**Command Modes**

CONFIGURATION

**Supported Modes**

All Modes

**Command History**

Version	Description
9.9(0.0)	Introduced on the FN IOM.
9.4(0.0)	Supported on the FN I/O Aggregator.
8.3.17.0	Supported on the M I/O Aggregator.

**Usage Information**

The host name is used in the prompt.

**Related Commands**

[feature unique-name](#)

# http-server

Disable / Enable the Blade I/O Manager Software.

**Syntax** `http-server blademgr`

**Parameters** **blademgr** Enter the keyword `blademgr` and specify the port for HTTP.

**Defaults** ENABLED

**Command Modes** CONFIGURATION

**Command History** This guide is platform-specific. For command information about other platforms, see the relevant *Dell Networking OS Command Line Reference Guide*.

Version	Description
9.11(0.0)	Introduced on the Stomp IOA and MXL-IOA

**Usage Information** By default, the Blade I/O Manager is enabled and there is no entry in the running configuration. Using the command `no http-server blademgr`, disables the Blade I/O Manager and also a “no http-server” entry is made in the running configuration. To re-enable the Blade I/O Manager, use the command `http-server blademgr` which enables the feature and also removes the entry from the running configuration. On reload, if the system detects a “no http-server” entry in the start-config, the feature will be disabled.

 **NOTE:** Please ensure to save and reload the configuration for the changes to take effect.

# ip telnet server enable

Enable the Telnet server on the switch.

**Syntax** `ip telnet server enable`

To disable the Telnet server, use the `no ip telnet server enable` command.

**Defaults** Enabled

**Command Modes** CONFIGURATION

**Supported Modes** All Modes

Command History	Version	Description
	9.9(0.0)	Introduced on the FN IOM.
	9.4(0.0)	Supported on the FN I/O Aggregator.
	8.3.17.0	Supported on the M I/O Aggregator.

# ip telnet source-interface

Set an interface's IP address as the source address in outgoing packets for Telnet sessions.

**Syntax** `ip telnet source-interface interface`

**Parameters** **interface** Enter the following keyword and slot/port or number information:

- For a 10-Gigabit Ethernet interface, enter the keyword `TenGigabitEthernet` followed by the slot/port information.
- For VLAN interface, enter the keyword `vlan` then a number from 1 to 4094.

**Defaults** The IP address on the system that is closest to the Telnet address is used in the outgoing packets.

**Command Modes** CONFIGURATION

**Supported Modes** All Modes

Command History	Version	Description
	<b>9.9(0.0)</b>	Introduced on the FN IOM.
	<b>9.4(0.0)</b>	Supported on the FN I/O Aggregator.
	<b>8.3.17.0</b>	Supported on the M I/O Aggregator.

**Related Commands** [telnet](#) — telnets to another device.

## line

Enable and configure console and virtual terminal lines to the system. This command accesses LINE mode, where you can set the access conditions for the designated line.

**Syntax** `line {console 0 | vty number [end-number]}`

Parameters		
<b>console 0</b>	Enter the keyword <code>console 0</code> to configure the console port. The console option is <0-0>.	
<b>vty number</b>	Enter the keyword <code>vty</code> followed by a number from 0 to 9 to configure a virtual terminal line for Telnet sessions. The system supports 10 Telnet sessions.	
<b>end-number</b>	(OPTIONAL) Enter a number from 1 to 9 as the last virtual terminal line to configure. You can configure multiple lines at one time.	

**Defaults** Not configured

**Command Modes** CONFIGURATION

**Supported Modes** All Modes

Command History	Version	Description
	<b>9.9(0.0)</b>	Introduced on the FN IOM.
	<b>9.4(0.0)</b>	Supported on the FN I/O Aggregator.
	<b>8.3.17.0</b>	Supported on the M I/O Aggregator.

**Usage Information** You cannot delete a terminal connection.

**Related Commands** [show memory](#)— View current memory usage on the M I/O Aggregator.

## ping

Test connectivity between the system and another device by sending echo requests and waiting for replies.

**Syntax** `ping [host | ip-address] [count {number | continuous}] [datagram-size] [timeout] [source (ip src-ipv4-address) | interface] [tos] [df-bit (y|n)] [validate-reply(y|n)] [pattern pattern] [sweep-min-size] [sweep-max-size] [sweep-interval] [ointerface (ip src-ipv4-address) | interface]`

<b>Parameters</b>	<b>host</b>	(OPTIONAL) Enter the host name of the devices to which you are testing connectivity.
	<b>ip-address</b>	(OPTIONAL) Enter the IPv4 address of the device to which you are testing connectivity. The address must be in the dotted decimal format.
	<b>count</b>	Enter the number of echo packets to be sent. The default is <b>5</b> . <ul style="list-style-type: none"> <li>● number: from 1 to 2147483647</li> <li>● continuous: transmit echo request continuously</li> </ul>
	<b>datagram size</b>	Enter the ICMP datagram size. The range is from 36 to 15360 bytes. The default is <b>100</b> .
	<b>timeout</b>	Enter the interval to wait for an echo reply before timing out. The range is from 0 to 3600 seconds. The default is <b>2 seconds</b> .
	<b>source</b>	Enter the IPv4 source ip address or the source interface. Enter the IP address in A.B.C.D format. <ul style="list-style-type: none"> <li>● For a 10-Gigabit Ethernet interface, enter the keyword <code>TenGigabitEthernet</code> then the slot/port information.</li> <li>● For a VLAN interface, enter the keyword <code>vlan</code> then a number from 1 to 4094.</li> </ul>
	<b>tos</b>	Enter the type of service required. The range is from 0 to 255. The default is <b>0</b> .
	<b>df-bit</b>	Enter Y or N for the “don't fragment” bit in IPv4 header. <ul style="list-style-type: none"> <li>● N: Do not set the “don't fragment” bit.</li> <li>● Y: Do set “don't fragment” bit</li> </ul> The default is <b>No</b> .
	<b>validate-reply</b>	Enter Y or N for reply validation. <ul style="list-style-type: none"> <li>● N: Do not validate reply data.</li> <li>● Y: Do validate reply data.</li> </ul> The default is <b>No</b> .
	<b>pattern pattern</b>	Enter the IPv4 data pattern. The range is from 0 to FFFF. The default is <b>0xABCD</b> .
	<b>sweep-min-size</b>	Enter the minimum size of datagram in sweep range. The range is from 52 to 15359 bytes.
	<b>sweep-max-size</b>	Enter the maximum size of datagram in sweep range. The range is from 53 to 15359 bytes.
	<b>sweep-interval</b>	Enter the incremental value for sweep size. The range is from 1 to 15308 seconds.
	<b>ointerface</b>	Enter the outgoing interface for multicast packets. Enter the IP address in A.B.C.D format. <ul style="list-style-type: none"> <li>● For a 10-Gigabit Ethernet interface, enter the keyword <code>TenGigabitEthernet</code> then the slot/port information.</li> <li>● For a VLAN interface, enter the keyword <code>vlan</code> then a number from 1 to 4094.</li> </ul>

**Defaults** See parameters above.

- Command Modes**
- EXEC
  - EXEC Privilege

**Supported Modes** All Modes

<b>Command History</b>	<b>Version</b>	<b>Description</b>
	<b>8.3.17.0</b>	Supported on the M I/O Aggregator.

**Usage Information** When you enter the `ping` command without specifying an IP address (Extended Ping), you are prompted for a target IP address, a repeat count, a datagram size (up to 1500 bytes), a timeout (in seconds), and for Extended Commands. For information on the ICMP message codes that return from a `ping` command, refer to [Internet Control Message Protocol \(ICMP\) Message Types](#).

## Example (IPv4)

```
Dell#ping 172.31.1.255

Type Ctrl-C to abort.

Sending 5, 100-byte ICMP Echos to 172.31.1.255, timeout is 2 seconds:
Reply to request 1 from 172.31.1.208 0 ms
Reply to request 1 from 172.31.1.216 0 ms
Reply to request 1 from 172.31.1.205 16 ms
::
Reply to request 5 from 172.31.1.209 0 ms
Reply to request 5 from 172.31.1.66 0 ms
Reply to request 5 from 172.31.1.87 0 ms
Dell#
```

## reload

Reboot the Dell Networking OS.

**Syntax** reload

**Command Modes** EXEC Privilege

**Supported Modes** All Modes

Command History	Version	Description
	<b>9.9(0.0)</b>	Introduced on the FN IOM.
	<b>9.4(0.0)</b>	Supported on the FN I/O Aggregator.
	<b>8.3.17.0</b>	Supported on the M I/O Aggregator.

**Usage Information** If there is a change in the configuration, the Dell Networking OS prompts you to save the new configuration. Or you can save your running configuration with the `copy running-config` command.

**Related Commands** [reset stack-unit](#) — resets any designated stack member except the management unit.

## service timestamps

Add time stamps to debug and log messages. This command adds either the uptime or the current time and date.

**Syntax** service timestamps [debug | log] [datetime [localtime] [msec] [show-timezone] | uptime]

Parameters		
<b>debug</b>	(OPTIONAL)	Enter the keyword <code>debug</code> to add timestamps to debug messages.
<b>log</b>	(OPTIONAL)	Enter the keyword <code>log</code> to add timestamps to log messages with severity from 0 to 6.
<b>datetime</b>	(OPTIONAL)	Enter the keyword <code>datetime</code> to have the current time and date added to the message.
<b>localtime</b>	(OPTIONAL)	Enter the keyword <code>localtime</code> to include the localtime in the timestamp.
<b>msec</b>	(OPTIONAL)	Enter the keyword <code>msec</code> to include milliseconds in the timestamp.
<b>show-timezone</b>	(OPTIONAL)	Enter the keyword <code>show-timezone</code> to include the time zone information in the timestamp.
<b>uptime</b>	(OPTIONAL)	Enter the keyword <code>uptime</code> to have the timestamp based on time elapsed since system reboot.

**Defaults** Not configured.

**Command Modes** CONFIGURATION

**Supported Modes** All Modes

<b>Command History</b>	<b>Version</b>	<b>Description</b>
	<b>9.9(0.0)</b>	Introduced on the FN IOM.
	<b>9.4(0.0)</b>	Supported on the FN I/O Aggregator.
	<b>8.3.17.0</b>	Supported on the M I/O Aggregator.

**Usage Information** If you do not specify parameters and enter `service timestamps`, it appears as `service timestamps debug uptime` in the running-configuration.

To view the current options set for the `service timestamps` command, use the `show running-config` command.

## show alarms

Display the active major and minor alarms on the system.

**Syntax** `show alarms`

**Command Modes**

- EXEC
- EXEC Privilege

**Supported Modes** All Modes

<b>Command History</b>	<b>Version</b>	<b>Description</b>
	<b>8.3.17.0</b>	Supported on the M I/O Aggregator.

### Example

```
Dell# show alarms

-- Minor Alarms --
Alarm Type                Duration
-----
No minor alarms

-- Major Alarms --
Alarm Type                Duration
-----
No major alarms

Dell#
```

## show command-history

Display a buffered log of all commands all users enter along with a time stamp.

**Syntax** `show command-history`

**Defaults** None

**Command Modes**

- EXEC
- EXEC Privilege

**Supported Modes** All Modes

<b>Command History</b>	<b>Version</b>	<b>Description</b>
	<b>9.9(0.0)</b>	Introduced on the FN IOM.



Version	Description
9.4(0.0)	Supported on the FN I/O Aggregator.
8.3.17.0	Supported on the M I/O Aggregator.

### Usage Information

One trace log message is generated for each command. No password information is saved to this file.

### Example

```
Dell#show command-history
[4/20 10:27:23]: CMD-(CLI):[enable]by default from console
[4/20 10:27:23]: CMD-(CLI):[configure terminal]by default from console
- Repeated 1 time.
[4/20 10:27:23]: CMD-(CLI):[snmp-server community public ro]by default
from
console
[4/20 10:27:23]: CMD-(CLI):[logging 172.16.1.162]by default from console
[4/20 10:27:23]: CMD-(CLI):[logging 10.10.10.4]by default from console
[4/20 10:27:24]: CMD-(CLI):[logging 10.1.2.4]by default from console
[4/20 10:27:24]: CMD-(CLI):[logging 172.31.1.4]by default from console
[4/20 10:27:24]: CMD-(CLI):[logging 133.33.33.4]by default from console
[4/20 10:27:24]: CMD-(CLI):[management route 172.16.1.0 /24
10.11.209.4]by default
from console
[4/20 10:27:24]: CMD-(CLI):[service timestamps log datetime]by default
from
console
[4/20 10:27:24]: CMD-(CLI):[line console 0]by default from console
[4/20 10:27:24]: CMD-(CLI):[exec-timeout 0]by default from console
[4/20 10:27:24]: CMD-(CLI):[exit]by default from console
[4/20 10:27:29]: CMD-(CLI):[show version]by default from console
[4/20 10:27:56]: CMD-(CLI):[show interfaces tengigabitethernet 0/3]by
default from
console
[4/20 10:55:8]: CMD-(CLI):[show lldp neighbors]by default from console
[4/20 15:17:6]: CMD-(CLI):[show cam-acl]by default from console
[4/20 16:34:59]: CMD-(CLI):[show running-config interface
tengigabitethernet 0/
55]by default from console
[4/20 16:38:14]: CMD-(CLI):[show vlan]by default from console
[5/4 9:11:52]: CMD-(TEL0):[show version]by admin from vty0 (10.11.68.14)
[5/4 9:12:9]: CMD-(TEL0):[show hosts]by admin from vty0 (10.11.68.14)
[5/4 9:14:38]: CMD-(TEL0):[show arp]by admin from vty0 (10.11.68.14)
[5/4 9:19:29]: CMD-(TEL0):[enable]by admin from vty0 (10.11.68.14)
[5/4 9:19:35]: CMD-(TEL0):[configure]by admin from vty0 (10.11.68.14)
- Repeated 1 time.
[5/4 9:19:50]: CMD-(TEL0):[interface tengigabitethernet 0/16]by admin
from vty0
(10.11.68.14)
[5/4 9:20:11]: CMD-(TEL0):[exit]by admin from vty0 (10.11.68.14)
Dell#
```

### Related Commands

[clear command history](#) — clears the command history log.

## show configuration lock

Display the configuration lock status.

**Syntax** `show configuration lock`

**Defaults** None

**Command Modes** EXEC Privilege

**Supported Modes** All Modes

<b>Command History</b>	<table border="0"> <thead> <tr> <th style="text-align: left;">Version</th> <th style="text-align: left;">Description</th> </tr> </thead> <tbody> <tr> <td><b>9.9(0.0)</b></td> <td>Introduced on the FN IOM.</td> </tr> <tr> <td><b>9.4(0.0)</b></td> <td>Supported on the FN I/O Aggregator.</td> </tr> <tr> <td><b>8.3.17.0</b></td> <td>Supported on the M I/O Aggregator.</td> </tr> </tbody> </table>	Version	Description	<b>9.9(0.0)</b>	Introduced on the FN IOM.	<b>9.4(0.0)</b>	Supported on the FN I/O Aggregator.	<b>8.3.17.0</b>	Supported on the M I/O Aggregator.
Version	Description								
<b>9.9(0.0)</b>	Introduced on the FN IOM.								
<b>9.4(0.0)</b>	Supported on the FN I/O Aggregator.								
<b>8.3.17.0</b>	Supported on the M I/O Aggregator.								
<b>Usage Information</b>	The type may be auto, manual, or rollback. When set to auto, Dell Networking OS automatically denies access to CONFIGURATION mode to all other users every time the user on the listed VTY line enters CONFIGURATION mode. When set to manual, the user on the listed VTY line must explicitly set the lock each time before entering CONFIGURATION mode. Rollback indicates that Dell Networking OS is in a rollback process. The line number shown in the output can be used to send the messages to that session or release a lock on a VTY line.								

**Example**

```
Dell#show configuration lock
Configure exclusively locked by the following line:
Line           : vty 0
Line number    : 2
User           : admin
Type           : AUTO
State          : LOCKED
Ip address     : 10.11.9.97
Dell#
```

## show cpu-traffic-stats

Display the CPU traffic statistics.

<b>Syntax</b>	<code>show cpu-traffic-stats [port number   all]</code>				
<b>Parameters</b>	<table border="0"> <tr> <td style="vertical-align: top;"><b>port number</b></td> <td>(OPTIONAL) Enter the port number to display traffic statistics on that port only. The range is from 1 to 1568.</td> </tr> <tr> <td style="vertical-align: top;"><b>all</b></td> <td>(OPTIONAL) Enter the keyword <code>all</code> to display traffic statistics on all the interfaces receiving traffic, sorted based on the traffic.</td> </tr> </table>	<b>port number</b>	(OPTIONAL) Enter the port number to display traffic statistics on that port only. The range is from 1 to 1568.	<b>all</b>	(OPTIONAL) Enter the keyword <code>all</code> to display traffic statistics on all the interfaces receiving traffic, sorted based on the traffic.
<b>port number</b>	(OPTIONAL) Enter the port number to display traffic statistics on that port only. The range is from 1 to 1568.				
<b>all</b>	(OPTIONAL) Enter the keyword <code>all</code> to display traffic statistics on all the interfaces receiving traffic, sorted based on the traffic.				
<b>Defaults</b>	<b>all</b>				
<b>Command Modes</b>	EXEC				
<b>Supported Modes</b>	All Modes				

<b>Command History</b>	<table border="0"> <thead> <tr> <th style="text-align: left;">Version</th> <th style="text-align: left;">Description</th> </tr> </thead> <tbody> <tr> <td><b>9.9(0.0)</b></td> <td>Introduced on the FN IOM.</td> </tr> <tr> <td><b>9.4(0.0)</b></td> <td>Supported on the FN I/O Aggregator.</td> </tr> <tr> <td><b>8.3.17.0</b></td> <td>Supported on the M I/O Aggregator.</td> </tr> </tbody> </table>	Version	Description	<b>9.9(0.0)</b>	Introduced on the FN IOM.	<b>9.4(0.0)</b>	Supported on the FN I/O Aggregator.	<b>8.3.17.0</b>	Supported on the M I/O Aggregator.
Version	Description								
<b>9.9(0.0)</b>	Introduced on the FN IOM.								
<b>9.4(0.0)</b>	Supported on the FN I/O Aggregator.								
<b>8.3.17.0</b>	Supported on the M I/O Aggregator.								

**Usage Information** Traffic statistics are sorted on a per-interface basis; the interface receiving the most traffic is displayed first. All CPU and port information is displayed unless a specific port or CPU is specified. Traffic information is displayed for router ports only; not for management interfaces. The traffic statistics are collected only after the `debug cpu-traffic-stats` command is executed; not from the system bootup.

**NOTE:** After debugging is complete, use the `no debug cpu-traffic-stats` command to shut off traffic statistics collection.

**Example**

```
Dell#show cpu-traffic-stats
Processor : CP
-----
Received 100% traffic on TenGigabitEthernet 8/2 Total packets:100
LLC:0, SNAP:0, IP:100, ARP:0, other:0
```

```
Unicast:100, Multicast:0, Broadcast:0
Dell#
```

**Related  
Commands**

[debug cpu-traffic-stats](#) — enables CPU traffic statistics for debugging.

## show debugging

View a list of all enabled debugging processes.

**Syntax** `show debugging`

**Command Modes** EXEC Privilege

**Supported Modes** All Modes

Command History	Version	Description
	<b>9.9(0.0)</b>	Introduced on the FN IOM.
	<b>9.4(0.0)</b>	Supported on the FN I/O Aggregator.
	<b>8.3.17.0</b>	Supported on the M I/O Aggregator.

**Example**

```
Dell#show debug
Generic IP: (Access List: test)
  IP packet debugging is on for (Access List: test)
    TenGigabitEthernet 0/16
  ICMP packet debugging is on for
    TenGigabitEthernet 0/16
OSPF:1
  OSPF packet debugging is on
DHCP:
  DHCP debugging is on
Dell#
```

## show diag

Display the diagnostics information.

**Syntax** `show diag {information | stack-unit number [detail | summary]] | testcase}`

Parameters	
<b>information</b>	Enter the keyword <code>information</code> to view current diagnostics information in the system.
<b>stack-unit <i>unit-id</i></b>	(OPTIONAL) Enter the keywords <code>stack-unit</code> then the <code>unit-id</code> to display information on a specific stack member. The range is from 0 to 5.
<b>detail</b>	(OPTIONAL) Enter the keyword <code>detail</code> to view detailed diagnostics information.
<b>summary</b>	(OPTIONAL) Enter the keyword <code>summary</code> to view a summary of the diagnostics information.
<b>testcase</b>	Enter the keyword <code>testcase</code> to view current diagnostics testcases available in the system.

**Defaults** Summary

**Command Modes** EXEC Privilege

**Supported Modes** All Modes

Command History	Version	Description
	<b>9.9(0.0)</b>	Introduced on the FN IOM.
	<b>9.4(0.0)</b>	Supported on the FN I/O Aggregator.
	<b>8.3.17.0</b>	Supported on the M I/O Aggregator.

## show environment

Displays the system component status (for example, temperature or voltage).

**Syntax** `show environment [all | stack-unit unit-id]`

Parameters	all	stack-unit <i>unit-id</i>	thermal sensor
	Enter the keyword <code>all</code> to view all components.	Enter the keywords <code>stack-unit</code> then the <code>unit-id</code> to display information on a specific stack member. The range is from 0 to 5.	Enter the keywords <code>thermal-sensor</code> to view all components.

- Command Modes**
- EXEC
  - EXEC Privilege

**Supported Modes** All Modes

Command History	Version	Description
	<b>9.9(0.0)</b>	Introduced on the FN IOM.
	<b>9.4(0.0)</b>	Supported on the FN I/O Aggregator.
	<b>8.3.17.0</b>	Supported on the M I/O Aggregator.

### Example (all)

```
Dell#show environment all
-- Unit Environment Status --
Unit  Status  Temp  Voltage  TempStatus
-----
* 1  online   66C   ok       2
* Management Unit
-- Thermal Sensor Readings (deg C) --
Unit  Sensor0  Sensor1  Sensor2  Sensor3  Sensor4  Sensor5  Sensor6  Sensor7
Sensor8  Sensor9
-----
1      51      51      63      61      61      61      67      61
64      66
Dell#
```

### Example (stack-unit)

```
Dell#show environment stack-unit
-- Unit Environment Status --
Unit  Status  Temp  Voltage  TempStatus
-----
* 1  online   66C   ok       2
* Management Unit
Dell#
```

### Example (thermal-sensor)

```
Dell#show environment thermal-sensor
-- Thermal Sensor Readings (deg C) --
Unit  Sensor0  Sensor1  Sensor2  Sensor3  Sensor4  Sensor5  Sensor6  Sensor7
Sensor8  Sensor9
-----
```

```

1      51      51      64      61      61      61      67      61
64
Dell#

```

## show inventory

Displays the switch type, components (including media), and Dell Networking OS version including hardware identification numbers and configured protocols.

**Syntax** `show inventory [media slot][optional-module]}`

**Parameters**

- media slot** (OPTIONAL) Enter the keyword `media` then the stack ID of the stack member you want to display pluggable media inventory.
- optional-module** (OPTIONAL) Enter the keyword `optional-module` to display optional module information.

**Defaults** none

**Command Modes** EXEC

**Supported Modes** All Modes

**Command History**

Version	Description
8.3.17.0	Supported on the M I/O Aggregator.

**Usage Information** If there are no fiber ports in the unit, just the header under `show inventory media` displays. If there are fiber ports but no optics inserted, the output displays "Media not present or accessible".

### Example

```

Dell#show inventory
System Type      : PE-FN-410S-IOA
System Mode      : 1.0
Software Version : 1-0(0-1859)

Unit Type          Serial Number  Part Number  Rev  Piece Part ID          Rev  Svc Tag  Exprs Svc Code
-----
* 0  PowerEdge-FN-410S-IOA TW000000000020  07NVPVX01   X01  TW-07NVPV-00000-000-0020 X01  N/A      N/A

* - Management Unit

Software Protocol Configured
-----
DCBX
FIP Snooping
IGMP
iSCSI
LLDP
SNMP
Dell#

```

### Example (media)

```

Dell#show inventory media ?
<0-5>          Slot number
|              Pipe through a command

Dell#show inventory media
Slot  Port  Type      Media          Serial Number      F10Qualified
-----
0     9      SFP+      10GBASE-CU1M   APF11380028XGQ     Yes
0     10     SFP+      10GBASE-CU2M   APF12090032HDL     Yes
0     11     SFP+      10GBASE-CU2M   APF12090032HFB     Yes
0     12     SFP+      10GBASE-CU0.5M APF12490013FP2     Yes
Dell#

```

### Example (optional-module)

```

Dell#show inventory optional-module
Unit Slot Expected Inserted Next Boot Status/Power (On/Off)
-----
1     0      SFP+      SFP+          AUTO      Good/On
1     1      QSFP+     QSFP+         AUTO      Good/On
* - Mismatch
Dell#

```

**Related Commands** [show config \(from INTERFACE VLAN mode\)](#) — displays information on a specific physical interface or virtual interface.

# show memory

Display current memory usage on the M I/O Aggregator.

**Syntax** `show memory [stack-unit 0-5]`

**Parameters** **stack-unit 0-5** (OPTIONAL) Enter the keywords `stack-unit` then the stack unit ID of the stack member to display memory information on the designated stack member.

**Command Modes**

- EXEC
- EXEC Privilege

**Supported Modes** All Modes

Command History	Version	Description
	<b>9.9(0.0)</b>	Introduced on the FN IOM.
	<b>9.4(0.0)</b>	Supported on the FN I/O Aggregator.
	<b>8.3.17.0</b>	Supported on the M I/O Aggregator.

**Usage Information** The output for `show memory` command displays the memory usage of LP part (`sysdlp`) of the system. The `sysdlp` is an aggregate task that handles all the tasks running on the CPU.

**Example**

```
Dell#show memory
      Statistics On Unit 0 Processor
      =====
      Total(b)   Used(b)   Free(b)   Lowest(b)   Largest(b)
268435456  4010354  264425102  264375410  264425102
```

# show processes cpu

Display CPU usage information based on processes running.

**Syntax** `show processes cpu [management-unit 1-99 [details] | stack-unit 0-5 | summary | ipc | memory [stack-unit 0-5]]`

**Parameters**

- management-unit 1-99 [details]** (OPTIONAL) Display processes running in the control processor. The 1-99 variable sets the number of tasks to display in order of the highest CPU usage in the past five (5) seconds. Add the keyword `details` to display all running processes (except `sysdlp`). Refer to Example (management-unit).
- stack-unit 0-5** (OPTIONAL) Enter the keywords `stack-unit` then the stack member ID. The range is from 0 to 5.  
  
As an option of the `show processes cpu` command, this option displays CPU usage for the designated stack member. Or, as an option of `memory`, this option limits the output of memory statistics to the designated stack member. Refer to Example (stack-unit).
- summary** (OPTIONAL) Enter the keyword `summary` to view a summary view CPU utilization of processes related to line card processing. Refer to Example (summary).
- ipc** (OPTIONAL) Enter the keyword `ipc` to display interprocess communication statistics.
- memory** (OPTIONAL) Enter the keyword `memory` to display memory statistics. Refer to Example (memory).

**Command Modes**

- EXEC
- EXEC Privilege

**Supported Modes** All Modes

**Command History**

Version	Description
8.3.17.0	Supported on the M I/O Aggregator.

**Example (summary)**

```
Dell#show processes cpu summary

CPU utilization          5Sec    1Min    5Min
-----
UNIT1                    4%     3%     2%
```

**Example (management-unit)**

```
Dell#show processes cpu management-unit 5
CPU utilization for five seconds: 4%/0%; one minute: 4%; five minutes: 4%
PID          Runtime(ms) Invoked  uSecs  5Sec  1Min  5Min  TTY
Process
0x00000000  2120         212    10000  3.77% 3.77% 3.77% 0
system
0x00000112  2472940      247294  10000  0.79% 0.61% 0.65% 0
sysdlp
0x000000e4  495560       49556   10000  0.20% 0.25% 0.24% 0
sysd
0x0000013d  34310        3431    10000  0.00% 0.02% 0.00% 0
lacp
0x00000121  4190         419     10000  0.00% 0.02% 0.00% 0
iscsiOpt

PID Runtime(ms) Invoked uSecs 5Sec 1Min 5Min TTY Process
Dell#
```

**Example (stack-unit)**

```
Dell#show process cpu stack-unit 1
CPU utilization for five seconds: 4%/0%; one minute: 3%; five minutes: 2%
PID          Runtime(ms) Invoked  uSecs  5Sec  1Min  5Min  TTY Process
0x763a3000  17981680     1798168  10000  3.00% 2.67% 2.67% 0 KP
0x762ba000  0             0         0      0.00% 0.00% 0.00% 0 debugagt
0x762d9000  0             0         0      0.00% 0.00% 0.00% 0 F10StkMgr
0x762f8000  214590       21459    10000  0.00% 0.00% 0.00% 0 lcMgr
0x76319000  7890         789      10000  0.00% 0.00% 0.00% 0 dla
0x76344000  155770       15577    10000  0.00% 0.00% 0.02% 0 sysAdmTsk
0x76363000  583230       58323    10000  0.00% 0.00% 0.02% 0 timerMgr
0x76381000  658850       65885    10000  0.00% 0.17% 0.08% 0 PM
0x76299000  80110        8011     10000  0.00% 0.00% 0.00% 0 diagagt
0x763c3000  0             0         0      0.00% 0.00% 0.00% 0 evagt
--More--
```

**Example (memory)**

```
Dell#show processes memory

Memory Statistics Of Stack Unit 1 (bytes)
=====
Total: 2147483648, MaxUsed: 499019776, CurrentUsed: 499019776,
CurrentFree:
1648463872
TaskName      TotalAllocated      TotalFreed      MaxHeld      CurrentHolding
f10appioserv  225280              0              0              192512
fcoecntrl     270336              0              0              9277440
f10appioserv  225280              0              0              192512
iscsiOpt      114688              0              0              7380992
dhclient      552960              0              0              1626112
f10appioserv  225280              0              0              192512
ndpm          618496              0              0              7389184
f10appioserv  225280              0              0              192512
vrrp          335872              0              0              7712768
f10appioserv  225280              0              0              192512
frrp          180224              0              0              7192576
f10appioserv  225280              0              0              192512
xstp          2740224             0              0              9445376
f10appioserv  225280              0              0              192512
```

```

pim 1007616 0 0 0 7585792
f10appioserv 225280 0 0 0 192512
igmp 417792 0 0 0 14774272
f10appioserv 225280 0 0 0 192512
mrtm 5496832 0 0 0 12636160
f10appioserv 225280 0 0 0 192512
l2mgr 1040384 0 0 0 42471424
f10appioserv 225280 0 0 0 192512
l2pm 176128 0 0 0 24166400
f10appioserv 225280 0 0 0 192512
arpm 192512 0 0 0 6955008
f10appioserv 225280 0 0 0 192512
otm 184320 0 0 0 7127040

--More--
Dell#

```

### Example (stack-unit)

```

Dell#show process memory stack-unit 1
Total: 2147483648, MaxUsed: 499040256, CurrentUsed: 499040256,
CurrentFree:
1648443392
TaskName      TotalAllocated      TotalFreed      MaxHeld      CurrentHolding
f10appioserv      225280              0              0              192512
fcoecntrl        270336              0              0              9277440
f10appioserv      225280              0              0              192512
iscsiOpt         114688              0              0              7380992
dhclient         552960              0              0              1626112
f10appioserv      225280              0              0              192512
ndpm             618496              0              0              7389184
f10appioserv      225280              0              0              192512
vrrp             335872              0              0              7712768
f10appioserv      225280              0              0              192512
frrp             180224              0              0              7192576
f10appioserv      225280              0              0              192512
xstp             2740224             0              0              9445376
f10appioserv      225280              0              0              192512
pim             1007616             0              0              7585792
f10appioserv      225280              0              0              192512
igmp             417792              0              0              14774272
f10appioserv      225280              0              0              192512
mrtm            5496832             0              0              12636160

--More--
Dell#

```

### Related Commands

[show diag](#)— displays the data plane or management plane input and output statistics of the designated component of the designated stack member.

[show hardware system-flow](#)— displays Layer 3 ACL or QoS data for the selected stack member and stack member port-pipe.

[show interfaces stack-unit](#)— displays information on all interfaces on a specific stack member.

[show processes memory](#)— displays CPU usage information based on running processes.

## show processes ipc flow-control

Displays the single window protocol queue (SWPQ) statistics.

**Syntax** `show processes ipc flow-control [cp]`

**Parameters** **cp** (OPTIONAL) Enter the keyword `cp` to view the control processor's SWPQ statistics.

**Defaults** none



- Command Modes**
- EXEC
  - EXEC Privilege

**Supported Modes** All Modes

**Command History**

Version	Description
9.9(0.0)	Introduced on the FN IOM.
9.4(0.0)	Supported on the FN I/O Aggregator.
8.3.17.0	Supported on the M I/O Aggregator.

**Usage Information**

Field	Description
<b>Source QID /Tx Process</b>	Source Service Identifier
<b>Destination QID/Rx Process</b>	Destination Service Identifier
<b>Cur Len</b>	Current number of messages enqueued
<b>High Mark</b>	Highest number of packets in the queue at any time
<b>#of to / Timeout</b>	Timeout count
<b>#of Retr /Retries</b>	Number of retransmissions
<b>#msg Sent/Msg Sent/</b>	Number of messages sent
<b>#msg Ackd/Ack Rcvd</b>	Number of messages acknowledged
<b>Retr /Available Retra</b>	Number of retries left
<b>Total/ Max Retra</b>	Number of retries allowed

**Important Points:**

- The SWP provides flow control-based reliable communication between the sending and receiving software tasks.
- A sending task enqueues messages into the SWP queue<sup>3</sup> for a receiving task and waits for an acknowledgement.
- If no response is received within a defined period of time, the SWP timeout mechanism resubmits the message at the head of the FIFO queue.
- After retrying a defined number of times, the SWP-2-NOMORETIMEOUT timeout message is generated.
- In the example, a retry (Retries) value of zero indicates that the SWP mechanism reached the maximum number of retransmissions without an acknowledgement.

**Example**

```
Dell#show processes ipc flow-control

Q Statistics on CP Processor
TxProcess RxProcess  Cur   High  Time  Retr Msg   Ack Aval  Max
          Len   Mark  Out   ies Sent  Rcvd Retra Retra ACL0  RTM0
          0    0    0    0    0    0    0    0    10   10
DIFFSERV0
          0    0    0    0    0    0    0    0    10   10
ACL0     IGMP0
          0    0    0    0    0    0    0    0    10   10
ACL0     PIM0
LACP0    IFMGR0  0  24    0    0    34    34    25   25
STP0     L2PM0   0    0    0    0    0    0    25   25
L2PM0    STP0    0    1    0    0    2    2    25   25
FRRP0    L2PM0   0    0    0    0    0    0    25   25
DHCP0    ACL0    0    0    0    0    0    0    25   25
DHCP0    IFMGR0  0    0    0    0    0    0    25   25
DHCP0    IFMGR0  0    0    0    0    0    0    25   25
SMUX0    IFMGR0  0  38    0    0    47    47    60   60
SMUX0    LACP0   0    1    0    0    3    3    60   60
```

```
--More--
```

```
Dell#
```

## show processes memory

Display memory usage information based on processes running in the system.

**Syntax** `show processes memory {management-unit | stack unit {0-5 | all | summary}}`

**Parameters**

<b>management-unit</b>	Enter the keywords <code>management-unit</code> for CPU memory usage of the stack management unit.
<b>stack unit 0-5</b>	Enter the keywords <code>stack unit</code> then a stack unit ID of the member unit for which to display memory usage on the forwarding processor.
<b>all</b>	Enter the keyword <code>all</code> for detailed memory usage on all stack members.
<b>summary</b>	Enter the keyword <code>summary</code> for a brief summary of memory availability and usage on all stack members.

**Command Modes**

- EXEC
- EXEC Privilege

**Supported Modes** All Modes

Command History	Version	Description
	<b>9.9(0.0)</b>	Introduced on the FN IOM.
	<b>9.4(0.0)</b>	Supported on the FN I/O Aggregator.
	<b>8.3.17.0</b>	Supported on the M I/O Aggregator.

**Usage Information** `show processes memory output`

Field	Description
<b>Total:</b>	Total system memory available
<b>MaxUsed:</b>	Total maximum memory used ever (history indicated with time stamp)
<b>CurrentUsed:</b>	Total memory currently in use
<b>CurrentFree:</b>	Total system memory available
<b>SharedUsed:</b>	Total used shared memory
<b>SharedFree:</b>	Total free shared memory
<b>PID</b>	Process ID
<b>Process</b>	Process Name
<b>ResSize</b>	Actual resident size of the process in memory
<b>Size</b>	Process test, stack, and data size
<b>Allocs</b>	Total dynamic memory allocated
<b>Frees</b>	Total dynamic memory freed
<b>Max</b>	Maximum dynamic memory allocated
<b>Current</b>	Current dynamic memory in use

The output for the `show process memory` command displays the memory usage statistics running on CP part (sysd) of the system. The sysd is an aggregate task that handles all the tasks running on the M I/O Aggregator's CP.

The output of the `show memory` command and this command differ based on which the Dell Networking OS processes are counted.

- In the `show memory` output, the memory size is equal to the size of the application processes.
- In the output of this command, the memory size is equal to the size of the application processes plus the size of the system processes.

### Example

```
Dell#show processes memory stack-unit 1
Total:2147483648, MaxUsed:499040256, CurrentUsed:499040256,
CurrentFree:1648443392
TaskName      TotalAllocated TotalFreed MaxHeld   CurrentHolding
f10appioserv  225280         0         0         192512
fcoecntrl     270336         0         0         9277440
f10appioserv  225280         0         0         192512
iscsiOpt      114688         0         0         7380992
dhclient      552960         0         0         1626112
f10appioserv  225280         0         0         192512
ndpm          618496         0         0         7389184
f10appioserv  225280         0         0         192512
vrrp          335872         0         0         7712768
f10appioserv  225280         0         0         192512
frrp          180224         0         0         7192576
f10appioserv  225280         0         0         192512
xstp          2740224        0         0         9445376
f10appioserv  225280         0         0         192512
pim           1007616        0         0         7585792
f10appioserv  225280         0         0         192512
igmp          417792         0         0         14774272
f10appioserv  225280         0         0         192512
mrtm          5496832        0         0         12636160

--More--
```

### Example (management-unit)

```
Dell#show processes memory management-unit
Total:2147483648, MaxUsed:499093504 [07/23/2012 17:42:16]
CurrentUsed:499093504, CurrentFree:1648390144
SharedUsed:18470440, SharedFree:2501104

PID Process    ResSize  Size    Allocs  Frees   Max Current
633 fcoecntrl  9277440 270336 1380528 132512 1281144 1248016
289 iscsiOpt   7380992 114688 23262   16564   23262   6698
476 dhclient   1626112 552960 0        0        0        0
521 ndpm       7389184 618496 4848    0        4848    4848
160 vrrp       7712768 335872 880     0        880     880
318 frrp       7192576 180224 71086   66256   21394   4830
218 xstp      9445376 2740224 21858   0        21858   21858
277 pim       7585792 1007616 62168   0        62168   62168

--More--
```

## show reset-reason

Display the reason for the last system reboot.

**Syntax** `show reset-reason [stack-unit {stack-unit-number | all}]`

**Parameters**

**stack-unit unit-number** (OPTIONAL) Enter the keyword `stack-unit` and the stack unit number to view the reason for the last system reboot for that stack unit.

**all** (OPTIONAL) Enter the keyword `stack-unit` and the keyword `all` to view the reason for the last system reboot of all stack units in the stack.

**Command Modes**

- EXEC
- EXEC Privilege

## Command History

This guide is platform-specific. For command information about other platforms, see the relevant *Dell EMC Networking OS Command Line Reference Guide*.

Version	Description
9.14(0.0)	Introduced on the S5048F-ON.
9.13(0.0)	Introduced on the S3048-ON, S3100 series, S4048-ON, S4048T-ON, S5000, S6000, S6000-ON, S6010-ON, S6100-ON, Z9100-ON, C9010, MXL, M-IOA, and FN-IOM.

## Usage Information

You can use the `show reset-reason` without the `stack-unit` option to view the reason for the last system reboot of the local system.

### Example — User-initiated reboot with the `reload` command

```
DellEMC#show reset-reason
Cause      : Reset by User through CLI command
Reset Time: 11/05/2017-08:36
```

### Example — System reboot due to the upgrade command

```
DellEMC# show reset-reason
Cause: Reboot by Software upgrade Module.
Reset Time: 8/9/2017 1:39 PM.
```

### Example — System reboot for unknown reasons

```
DellEMC# show reset-reason
Cause: N/A
Reload Time: N/A
```

### Example — System reboot due to power loss or pressing the power button off and on.

The example shows the reason for the last reboot as N/A for warm reset.

```
DellEMC#show reset-reason
Cause      : N/A
Reset Time : N/A.
```

### Example — System reboot due to watchdog timeout

```
DellEMC#show reset-reason
Cause: N/A.
Reset Time: N/A
```

### Example — System reboot due to thermal shutdown

The example shows the reason for the last reboot as N/A for thermal shutdown.

```
DellEMC# show reset-reason
Cause: N/A
Reload Time: N/A
```

### Example — System reboot due to BIOS boot fail

The example shows the reason for the last reboot as N/A for BIOS boot fail.

```
DellEMC#show reset-reason
Cause: NA
Reset Time: N/A.
```

### Example — Unknown reason

If the reason for the last system reboot is not available, the system displays the reason as N/A.

```
DellEMC# show reload-reason
Cause: N/A
Time: N/A
```

### Example — Reset reason of a single stack unit

```
DellEMC# show reset-reason stack-unit 1
Cause      : Reset by User through CLI command
Reset Time: 11/05/2017-08:36
```

### Example — Reset reason of all stack units

```
DellEMC#show reset-reason stack-unit all

Last Reset Reason:
-----
Type                               Cause                               Time
-----
stack-unit 1                       Reboot by Software                 11/05/2017-09:04
stack-unit 2                       Reboot by Software                 11/05/2017-09:04
stack-unit 3                       Cold Reset                          N/A
stack-unit 4                       N/A                                N/A
stack-unit 5                       N/A                                N/A
stack-unit 6                       N/A                                N/A
```

## show revision

Displays the revision numbers of all stack-units.

**Syntax** `show revision`

**Command Modes** • EXEC Privilege

**Supported Modes** All Modes

Command History	Version	Description
	<b>9.9(0.0)</b>	Introduced on the FN IOM.
	<b>9.4(0.0)</b>	Supported on the FN I/O Aggregator.
	<b>8.3.17.0</b>	Supported on the M I/O Aggregator.

### Example (Command)

```
Dell#show revision
-- Stack unit 1 --
IOM SYSTEM CPLD : 1
Dell#
```

## show server-interfaces

Displays server port information.

**Syntax** `show server-interfaces{brief|detail}`

**Command Modes** • EXEC Privilege

**Supported Modes** All Modes

Command History	Version	Description
	<b>9.4(0.0)</b>	Supported on the FN I/O Aggregator.
	<b>8.3.17.0</b>	Supported on the M I/O Aggregator .

### Example (brief Command)

```
Dell#show server-interfaces brief

----- show server ports brief -----

Interface                OK  Status  Protocol  Description
TenGigabitEthernet 0/1  YES  up        up
TenGigabitEthernet 0/2  YES  up        up
TenGigabitEthernet 0/3  YES  up        up
TenGigabitEthernet 0/4  NO   up        down
TenGigabitEthernet 0/5  YES  up        up
TenGigabitEthernet 0/6  NO   up        down
TenGigabitEthernet 0/7  YES  up        up
TenGigabitEthernet 0/8  NO   up        down
```

```

----- show lacp
-----
Interface          OK Status      Protocol   Description
Port-channel 1    YES up        up
Dell#

```

### Example (detail Command)

```

Dell#show server-interfaces detail

----- show server ports detail -----

TenGigabitEthernet 0/1 is up, line protocol is up
Hardware is DellEth, address is 00:1e:c9:de:03:79
  Current address is 00:1e:c9:de:03:79
Server Port AdminState is N/A
Pluggable media not present
Interface index is 33886978
Internet address is not set
Mode of IPv4 Address Assignment : NONE
DHCP Client-ID :001ec9de0379
MTU 12000 bytes, IP MTU 11982 bytes
LineSpeed 10000 Mbit
Flowcontrol rx off tx off
ARP type: ARPA, ARP Timeout 04:00:00
Last clearing of "show interface" counters 2d16h24m
Queueing strategy: fifo
Input Statistics:
  10701 packets, 1123557 bytes
  0 64-byte pkts, 10701 over 64-byte pkts, 0 over 127-byte pkts
  0 over 255-byte pkts, 0 over 511-byte pkts, 0 over 1023-byte pkts
  10701 Multicasts, 0 Broadcasts
  0 runts, 0 giants, 0 throttles
  0 CRC, 0 overrun, 0 discarded
Output Statistics:
  442113 packets, 46047526 bytes, 0 underruns
  870 64-byte pkts, 362829 over 64-byte pkts, 55411 over 127-byte pkts
--More--

```

## show system

Displays the current status of all stack members or a specific stack member.

**Syntax** `show system [brief | stack-unit unit-id]`

**Parameters**

- brief** (OPTIONAL) Enter the keyword `brief` to view an abbreviated list of system information.
- stack unit *unit-id*** (OPTIONAL) Enter the keywords `stack unit` then the stack member ID for information on the stack member. The range is from 0 to 5.

**Command Modes**

- EXEC
- EXEC Privilege

**Supported Modes** All Modes

Command History	Version	Description
	<b>9.11(0.0)</b>	Included the support for Stomp B1 chipset on FN IOM.
	<b>9.9(0.0)</b>	Introduced on the FN IOM.
	<b>9.4(0.0)</b>	Supported on the FN I/O Aggregator.
	<b>8.3.17.0</b>	Supported on the M I/O Aggregator.

### Example (show system brief command)

```

Dell#show system brief
Stack MAC      : 00:01:e8:00:ab:03

```

```

-- Stack Info --
Unit UnitType      Status      ReqTyp      CurTyp      Version      Ports
-----
  0 Member          not present
  1 Management     online      I/O-Aggregator I/O-Aggregator 9.11(0.0) 56
  2 Member          not present
  3 Member          not present
  4 Member          not present
  5 Member          not present
Dell#

```

**Example (stack-unit command)**

```

Dell#show system stack-unit 1
-- Unit 1 --
Unit Type : Management Unit
Status : online
Next Boot : online
Required Type : I/O-Aggregator - 34-port GE/TE (XL)
Current Type : I/O-Aggregator - 34-port GE/TE (XL)
Master priority : 0
Hardware Rev : 01
Num Ports : 56
Up Time : 4 day, 7 hr, 9 min
FTOS Version : 8-3-17-38
Jumbo Capable : yes
POE Capable : no
Boot Flash : A: 4.0.1.0bt [booted] B: 4.0.1.0bt1
Boot Selector : 4.0.0.0bt
Memory Size : 2147483648 bytes
Temperature : 67C
Voltage : ok
Switch Power : GOOD
Product Name : I/O Aggregator
Mfg By : DELL
Mfg Date :
Serial Number : 0000000000000000
Part Number : NVH81X01
Piece Part ID : 00-NVH81X-00000-000-0000
PPID Revision : 01
Service Tag : N/A
Expr Svc Code : N/A
Chassis Svce Tag: RTWB200
Fabric Id : C2
Asset tag : test
PSOC FW Rev : 0xb
ICT Test Date : 0-0-0
ICT Test Info : 0x0
Max Power Req : 31488
Fabric Type : 0x3
Fabric Maj Ver : 0x1
Fabric Min Ver : 0x0
SW Manageability: 0x4
HW Manageability: 0x1
Max Boot Time : 3 minutes
Link Tuning : unsupported
Auto Reboot : enabled
Burned In MAC : 00:01:e8:00:ab:03
No Of MACs : 3
Dell#

```

**Related Commands**

- [asset-tag](#) —Assign and store unique asset-tag to the stack member.
- [show version](#) — Displays the Dell version.
- [show processes memory](#) —Displays the memory usage based on the running processes.
- [show system stack-ports](#) — Displays information about the stack ports on all switches in the stack.
- [show diag](#) — Displays the data plane and management plane input and output statistics of a particular stack member.

# show tech-support

Displays a collection of data from other show commands, necessary for Dell Networking technical support to perform troubleshooting on Aggregators.

**Syntax** `show tech-support [stack-unit unit-id | page]`

**Parameters**

- stack-unit** (OPTIONAL) Enter the keyword `stack-unit` to view CPU memory usage for the stack member designated by `unit-id`. The range is 0 to 5.
- page** (OPTIONAL) Enter the keyword `page` to view 24 lines of text at a time. Press the SPACE BAR to view the next 24 lines. Press the ENTER key to view the next line of text.  
  
When using the pipe command ( `|` ), enter one of these keywords to filter command output. Refer to [CLI Basics](#) for details on filtering commands.
- save** Enter the keyword `save` to save the command output.  
  
flash: Save to local flash drive (`flash://filename` (max 20 chars))

**Command Modes** • EXEC Privilege

**Supported Modes** All Modes

Command History	Version	Description
	<b>9.14(0.0)</b>	Updated to display the <code>show revision</code> and <code>show os-version</code> command outputs.
	<b>9.9(0.0)</b>	Introduced on the FN IOM.
	<b>9.4(0.0)</b>	Supported on the FN I/O Aggregator.
	<b>8.3.17.0</b>	Supported on the M I/O Aggregator.

**Usage Information** Without the `page` or `stack-unit` option, the command output is continuous, use Ctrl-z to interrupt the command output.

The `save` option works with other filtering commands. This allows you to save specific information of a show command. The `save` entry must always be the last option.

For example: `Dell#show tech-support |grep regular-expression |except regular-expression | find regular-expression | save flash://result`

This display output is an accumulation of the same information that is displayed when you execute one of the following showcommands:

- `show cam`
- `show clock`
- `show environment`
- `show file`
- `show interfaces`
- `show inventory`
- `show processes cpu`
- `show processes memory`
- `show running-conf`
- `show version`
- `show os-version`
- `show revision`

## Example (save)

```
Dell#show tech-support ?
page           Page through output
stack-unit     Unit Number
```



```

| Pipe through a command
<cr>
Dell#show tech-support stack-unit 1 ?
page Page through output
| Pipe through a command
<cr>
Dell#show tech-support stack-unit 1 | ?
except S how only text that does not match a pattern
find Search for the first occurrence of a pattern
grep Show only text that matches a pattern
no-more Don't paginate output
save Save output to a file
Dell#show tech-support stack-unit 1 | save ?
flash: Save to local file system (flash://filename (max 20 chars) )
usbflash: Save to local file system (usbflash://filename (max 20
chars) )
Dell#show tech-support stack-unit 1 | save flash://LauraSave
Start saving show command report .....
Dell#
Dell#dir
Directory of flash:
Directory of flash:
1 drwx 4096 Jan 01 1980 01:00:00 +01:00 .
2 drwx 2048 May 16 2012 10:49:01 +01:00 ..
3 drwx 4096 Jan 24 2012 19:38:32 +01:00 TRACE_LOG_DIR
4 drwx 4096 Jan 24 2012 19:38:32 +01:00 CORE_DUMP_DIR
5 d-- 4096 Jan 24 2012 19:38:34 +01:00 ADMIN_DIR
6 -rwx 10303 Mar 15 2012 18:37:20 +01:00 startup-config.bak
7 -rwx 7366 Apr 20 2012 10:57:02 +01:00 startup-config
8 -rwx 4 Feb 19 2012 07:05:02 +01:00 dhcpBindConflict
9 -rwx 12829 Feb 18 2012 02:24:14 +01:00 startup-config.backup
10 drwx 4096 Mar 08 2012 22:58:54 +01:00 WJ_running-config
11 -rwx 7689 Feb 21 2012 04:45:40 +01:00 stbkup
flash: 2143281152 bytes total (2131476480 bytes free)
Dell

```

**Example (show tech-support)**

```

Dell#show tech-support page
----- show version
-----
Dell Real Time Operating System Software
Dell Operating System Version: 2.0
Dell Application Software Version: 9.14(0.0RC2)
Copyright (c) 1999-2018 by Dell Inc. All Rights Reserved.
Build Time: Tue Jul 3 14:02:08 2018
Build Path: /work/swbuild01_1/build02/E9-14-0/SW/SRC
Dell Networking OS uptime is 1 day(s), 22 hour(s), 14 minute(s)

System image file is "system://A"

System Type: PE-FN-410S-IOM
Control Processor: MIPS RMI XLP with 2 Gbytes (2147483648 bytes) of
memory, core(s) 1.

128M bytes of boot flash memory.

 1 12-port GE/TE (FN)
12 Ten GigabitEthernet/IEEE 802.3 interface(s)

----- show os version
-----
RELEASE IMAGE INFORMATION :
-----
Platform      Version      Size      ReleaseTime
F-Series:FN   9.14(0.0)   45304356  May 11 2018 12:45:01

TARGET IMAGE INFORMATION :
-----
Type          Version      Target      checksum

```

```

runtime          9.14(0.0)          Control Processor    passed
BOOT IMAGE INFORMATION :
-----
      Type          Version          Target          checksum
boot flash        4.1.1.1          Control Processor    passed
BOOTSEL IMAGE INFORMATION :
-----
      Type          Version          Target          checksum
boot selector     4.1.0.1          Control Processor    passed
CPLD IMAGE INFORMATION :
-----
      Card          CPLD Name          Version
Stack-unit 0      IOM SYSTEM CPLD          9

----- show revision
-----

-- Stack unit 1 --
IOM SYSTEM CPLD      : 9

----- show clock
-----
10:59:34.047 UTC Thu Jul 5 2018

<output truncated for brevity>

```

**Example (show tech-support stack-unit)**

```

Dell#show tech-support stack-unit 1
----- show version
-----
Dell Networking Real Time Operating System Software
Dell Networking Operating System Version: 1.0
Dell Networking Application Software Version: E8-3-17-38
Copyright (c) 1999-2012 by Dell Inc. All Rights Reserved.
Build Time: Thu Jul 19 05:59:59 PDT 2012
Build Path: /sites/sjc/work/swsystems01-2/ravisubramani/
ravis-8317/SW/SRC/Cp_src/
Tacacs
FTOS uptime is 4 day(s), 7 hour(s), 14 minute(s)
System image file is "dv-m1000e-2-b2"
System Type: I/O-Aggregator
Control Processor: MIPS RMI XLP with 2147483648 bytes of memory.
256M bytes of boot flash memory.
1 34-port GE/TE (XL)
56 Ten GigabitEthernet/IEEE 802.3 interface(s)
----- show clock
-----
17:49:37.2 UTC Mon Jul 23 2012
----- show running-config
-----
Current Configuration ...
! Version E8-3-17-38
! Last configuration change at Mon Jul 23 17:10:18 2012 by default
!
boot system stack-unit 1 primary tftp://10.11.9.21/dv-m1000e-2-b2
boot system stack-unit 1 default system: A:
boot system gateway 10.11.209.62
!
redundancy auto-synchronize full
!
service timestamps log datetime
!
hostname FTOS
----- show ip management route
-----
Destination Gateway State
-----
1

```

```
--More--
Dell#
```

### Related Commands

- [show version](#) — displays the Dell Networking OS version.
- [show system](#) — displays the current switch status..
- [show environment](#) — displays system component status.
- [show processes memory](#) — displays memory usage based on the running processes.

## show uplink brief

Displays the uplink port information.

**Syntax** `show uplink {brief|detail}`

**Parameters**

- brief** Enter the keyword `brief` to display a brief summary of the uplink port information.
- detail** Enter the keyword `detail` to display uplink port information with description.

**Command Modes** • EXEC Privilege

**Supported Modes** All Modes

### Command History

Version	Description
9.9(0.0)	Introduced on the FN IOM.
9.4(0.0)	Supported on the FN I/O Aggregator.
8.3.17.0	Supported on the M I/O Aggregator.

### Example (brief)

```
Dell#show uplink brief
----- show uplink brief -----
Interface          OK Status  Protocol Description
TenGigabitEthernet 0/41 NO up      down
TenGigabitEthernet 0/43 NO up      down
TenGigabitEthernet 0/44 NO up      down
TenGigabitEthernet 0/45 NO up      down
TenGigabitEthernet 0/46 NO up      down
TenGigabitEthernet 0/47 NO up      down
TenGigabitEthernet 0/48 NO up      down
TenGigabitEthernet 0/49 NO up      down
TenGigabitEthernet 0/50 NO up      down
TenGigabitEthernet 0/51 NO up      down
TenGigabitEthernet 0/52 NO up      down
TenGigabitEthernet 0/53 NO up      down
TenGigabitEthernet 0/54 NO up      down
TenGigabitEthernet 0/55 NO up      down
TenGigabitEthernet 0/56 NO up      down
TenGigabitEthernet 1/41 NO up      down
TenGigabitEthernet 1/42 NO up      down
TenGigabitEthernet 1/43 NO up      down
--More--
4 www.force10networks.com (10.11.84.18) 000.000 ms 000.000 ms 000.000 ms
Dell#
```

### Example (detail)

```
Dell#show uplink detail
----- show uplink detail -----
TenGigabitEthernet 0/41 is up, line protocol is down
Hardware is DellForce10Eth, address is 00:1e:c9:f1:00:99
Current address is 00:1e:c9:f1:00:99
Port is not present
Pluggable media not present
Interface index is 44634881
```

```

Internet address is not set
Mode of IP Address Assignment : NONE
DHCP Client-ID :tenG170001ec9f10099
MTU 12000 bytes, IP MTU 11982 bytes
LineSpeed auto
Flowcontrol rx on tx off
ARP type: ARPA, ARP Timeout 04:00:00
Last clearing of "show interface" counters 2d19h53m
Queueing strategy: fifo
Input Statistics:
 0 packets, 0 bytes
 0 64-byte pkts, 0 over 64-byte pkts, 0 over 127-byte pkts
 0 over 255-byte pkts, 0 over 511-byte pkts, 0 over 1023-byte pkts
 0 Multicasts, 0 Broadcasts
--More--

```

## show util-threshold cpu

Displays the set CPU utilization threshold values.

**Syntax** `show util-threshold cpu`

**Command Modes** • EXEC Privilege

**Supported Modes** All Modes

Command History	Version	Description
	<b>9.9(0.0)</b>	Introduced on the FN IOM.
	<b>9.4(0.0)</b>	Supported on the FN I/O Aggregator.
	<b>8.3.17.0</b>	Supported on the M I/O Aggregator.

**Usage Information** This command displays all CPU utilization thresholds of the management, standby, and stack-units.

## show util-threshold memory

Displays the set memory utilization threshold values.

**Syntax** `show util-threshold memory`

**Command Modes** • EXEC Privilege

**Supported Modes** All Modes

Command History	Version	Description
	<b>9.9(0.0)</b>	Introduced on the FN IOM.
	<b>9.4(0.0)</b>	Supported on the FN I/O Aggregator.
	<b>8.3.17.0</b>	Supported on the M I/O Aggregator.

**Usage Information** This command displays all memory utilization thresholds of the management, standby, and stack-units.

## ssh-peer-stack-unit

Open an SSH connection to the peer stack-unit.

**Syntax** `ssh-peer-stack-unit [-l username]`

**Parameters**      **-| username**      (OPTIONAL) Enter the keyword `-|` followed by your username.  
Default: The username associated with the terminal.

**Defaults**      Not configured.

**Command Modes**      • EXEC Privilege

**Supported Modes**      All Modes

<b>Command History</b>	<b>Version</b>	<b>Description</b>
	<b>9.9(0.0)</b>	Introduced on the FN IOM.
	<b>9.6(0.0)</b>	Supported on the FN I/O Aggregator.
	<b>8.3.17.0</b>	Supported on the M I/O Aggregator.

## telnet

Connect through Telnet to a server. The Telnet client and server in Dell Networking OS support IPv4 connections. You can establish a Telnet session directly to the router or a connection can be initiated from the router.

**Syntax**      `telnet {host | ip-address [/source-interface]}`

**Parameters**

- host**      Enter the name of a server.
- ip-address**      Enter the IPv4 address in dotted decimal format of the server.
- source-interface**      (OPTIONAL) Enter the keywords `/source-interface` then the interface information to include the source interface. Enter the following keywords and slot/port or number information:
  - For a 10-Gigabit Ethernet interface, enter the keyword `TenGigabitEthernet` then the slot/port information.
  - For a VLAN interface, enter the keyword `vlan` then a number from 1 to 4094.

**Defaults**      Not configured.

**Command Modes**      • EXEC  
• EXEC Privilege

**Supported Modes**      All Modes

<b>Command History</b>	<b>Version</b>	<b>Description</b>
	<b>9.9(0.0)</b>	Introduced on the FN IOM.
	<b>9.4(0.0)</b>	Supported on the FN I/O Aggregator.
	<b>8.3.17.0</b>	Supported on the M I/O Aggregator.

**Usage Information**      Telnet to link-local addresses is not supported.

## telnet-peer-stack-unit

Open a telnet connection to the peer stack-unit.

**Syntax**      `telnet-peer-stack-unit`

**Defaults**      Not configured.

**Command Modes**      • EXEC Privilege

**Supported Modes**      All Modes

Command History	Version	Description
	<b>9.9(0.0)</b>	Introduced on the FN IOM.
	<b>9.6(0.0)</b>	Supported on the FN I/O Aggregator.
	<b>8.3.17.0</b>	Supported on the M I/O Aggregator.

## terminal length

Configure the number of lines displayed on the terminal screen.

**Syntax** `terminal length screen-length`  
 To return to the default values, use the `no terminal length` command.

**Parameters** *screen-length* Enter a number of lines. Entering zero will cause the terminal to display without pausing. The range is from 0 to 512.  
 Default: 24 lines

**Defaults** 24 lines

**Command Modes**

- EXEC
- EXEC Privilege

**Supported Modes** All Modes

Command History	Version	Description
	<b>9.9(0.0)</b>	Introduced on the FN IOM.
	<b>9.4(0.0)</b>	Supported on the FN I/O Aggregator.
	<b>8.3.17.0</b>	Supported on the M I/O Aggregator.

## terminal monitor

Configure the Dell Networking OS to display messages on the monitor/terminal.

**Syntax** `terminal monitor`  
 To return to default settings, use the `no terminal monitor` command.

**Defaults** Disabled

**Command Modes**

- EXEC
- EXEC Privilege

**Supported Modes** All Modes

Command History	Version	Description
	<b>9.9(0.0)</b>	Introduced on the FN IOM.
	<b>9.4(0.0)</b>	Supported on the FN I/O Aggregator.
	<b>8.3.17.0</b>	Supported on the M I/O Aggregator.

# terminal xml

Enable XML mode in Telnet and SSH client sessions.

**Syntax** `terminal xml`  
To exit the XML mode, use the `no terminal monitor` command.

**Defaults** Disabled

- Command Modes**
- EXEC
  - EXEC Privilege

**Supported Modes** All Modes

Command History	Version	Description
	<b>9.9(0.0)</b>	Introduced on the FN IOM.
	<b>9.4(0.0)</b>	Supported on the FN I/O Aggregator.
	<b>8.3.17.0</b>	Supported on the M I/O Aggregator.

**Usage Information** This command enables XML input mode where you can either cut and paste XML requests or enter the XML requests line-by-line.

# trace route

View the packet path to a specific device.

**Syntax** `tracert {host | ip-address}`

**Parameters**

- host** Enter the name of device.
- ip-address** Enter the IP address of the device in dotted decimal format.

**Defaults** Timeout = 5 seconds; Probe count = 3; 30 hops max; 40 byte packet size; UDP port = 33434

- Command Modes**
- EXEC
  - EXEC Privilege

**Supported Modes** All Modes

Command History	Version	Description
	<b>9.9(0.0)</b>	Introduced on the FN IOM.
	<b>9.4(0.0)</b>	Supported on the FN I/O Aggregator.
	<b>8.3.17.0</b>	Supported on the M I/O Aggregator.

**Usage Information** When you enter the `tracert` command without specifying an IP address (Extended Traceroute), you are prompted for a target and source IP address, timeout in seconds (default is 5), a probe count (default is 3), minimum TTL (default is 1), maximum TTL (default is 30), and port number (default is 33434). To keep the default setting for those parameters, press the ENTER key.

## Example (IPv4)

```
Dell#tracert www.forcel0networks.com
Translating "www.forcel0networks.com"...domain server (10.11.0.1)
[OK]
Type Ctrl-C to abort.
-----
Tracing the route to www.forcel0networks.com (10.11.84.18),
 30 hops max, 40 byte packets
-----
TTL Hostname Probe1 Probe2 Probe3
 1 10.11.199.190 001.000 ms 001.000 ms 002.000 ms
 2 gwegress-sjc-02.forcel0networks.com (10.11.30.126)
   005.000 ms 001.000 ms 001.000 ms
 3 fw-sjc-01.forcel0networks.com (10.11.127.254)
   000.000 ms 000.000 ms 000.000 ms
 4 www.forcel0networks.com (10.11.84.18)
```

```
000.000 ms 000.000 ms 000.000 ms
Dell#
```

## Related Commands

[ping](#) — Tests the connectivity to a device.

# undebug all

Disable all debug operations on the system.

**Syntax** `undebug all`

**Defaults** `none`

**Command Modes** • EXEC Privilege

**Supported Modes** All Modes

Command History	Version	Description
	<b>9.9(0.0)</b>	Introduced on the FN IOM.
	<b>9.4(0.0)</b>	Supported on the FN I/O Aggregator.
	<b>8.3.17.0</b>	Supported on the M I/O Aggregator.

# write

Copy the current configuration to either the startup-configuration file or the terminal.

**Syntax** `write {memory | terminal}`

Parameters		
<b>memory</b>		Enter the keyword <code>memory</code> to copy the current running configuration to the startup configuration file. This command is similar to the <code>copy running-config startup-config</code> command.
<b>terminal</b>		Enter the keyword <code>terminal</code> to copy the current running configuration to the terminal. This command is similar to the <code>show running-config</code> command.

**Command Modes** • EXEC Privilege

**Supported Modes** All Modes

Command History	Version	Description
	<b>9.9(0.0)</b>	Introduced on the FN IOM.
	<b>9.4(0.0)</b>	Supported on the FN I/O Aggregator.
	<b>8.3.17.0</b>	Supported on the M I/O Aggregator.

**Usage Information** The `write memory` command saves the running-configuration to the file labeled startup-configuration. When using a LOCAL CONFIG FILE other than the startup-config not named "startup-configuration", the running-config is not saved to that file; use the `copy` command to save any running-configuration changes to that local file.



# u-Boot

All commands in this chapter are in u-Boot mode. These commands are supported on the Dell Networking Aggregator only. To access this mode, hit **Esc** key when the following line appears on the console during a system boot: Hit Esc key to interrupt autoboot:

You enter u-Boot immediately, as indicated by the `BOOT_USER#` prompt.

**NOTE:** Only the most frequently used commands available in uBoot mode are described in this chapter.

In uBoot mode, you cannot use the Tab key for command completion.

## Topics:

- [boot change](#)
- [boot selection](#)
- [boot show net config retries](#)
- [boot write net config retries](#)
- [boot zero](#)
- [default gateway](#)
- [enable](#)
- [help](#)
- [ignore enable password](#)
- [ignore startup-config](#)
- [interface management ethernet ip address](#)
- [no default gateway](#)
- [no interface management ethernet ip address](#)
- [reload](#)
- [show boot blc](#)
- [show boot selection](#)
- [show bootflash](#)
- [show bootvar](#)
- [show default gateway](#)
- [show interface management ethernet](#)
- [show interface management port config](#)
- [syntax help](#)

## boot change

Change the operating system boot parameters.

**Syntax** `boot change [primary | secondary | default]`

**Command Modes** uBoot

**Supported Modes** All Modes

Command History	Version	Description
	<b>9.4(0.0)</b>	Supported on the FN I/O Aggregator.
	<b>8.3.17.0</b>	Supported on the M I/O Aggregator.

## boot selection

Change the ROM bootstrap bootflash partition.

**Syntax** `boot selection[a | b]`

**Command Modes** • uBoot

**Command History** **Version 8.3.17.0** Supported on the M I/O Aggregator.

## boot show net config retries

Show the number of retries for network boot configuration failure.

**Syntax** `boot show net config retries`

**Command Modes** uBoot

**Supported Modes** All Modes

Command History	Version	Description
	<b>9.9(0.0)</b>	Introduced on the FN IOM.
	<b>9.4(0.0)</b>	Supported on the FN I/O Aggregator.
	<b>8.3.17.0</b>	Supported on the M I/O Aggregator.

### Example

```
BOOT_USER# boot show net config retries
Number of Network Boot Config Retries is : 0
BOOT_USER #
```

## boot write net config retries

Set the number of retries for network boot configuration failure.

**Syntax** `boot write net config retries <int>`

**Command Modes** uBoot

**Supported Modes** All Modes

Command History	Version	Description
	<b>9.9(0.0)</b>	Introduced on the FN IOM.
	<b>9.4(0.0)</b>	Supported on the FN I/O Aggregator.
	<b>8.3.17.0</b>	Supported on the M I/O Aggregator.

### Example

```
BOOT_USER # boot write net config retries 2
Updated number of Network Boot Config retries to 2.
BOOT_USER #
```

## boot zero

Clears the primary, secondary, or default boot parameters.

**Syntax** `boot zero [primary| secondary| default]`

**Command Modes** uBoot

**Supported Modes** All Modes

<b>Command History</b>	<b>Version</b>	<b>Description</b>
	<b>9.9(0.0)</b>	Introduced on the FN IOM.
	<b>9.4(0.0)</b>	Supported on the FN I/O Aggregator.
	<b>8.3.17.0</b>	Supported on the M I/O Aggregator.

## default gateway

Set the default gateway IP address.

**Syntax** `default-gateway <ip-address>`

**Command Modes** uBoot

**Supported Modes** All Modes

<b>Command History</b>	<b>Version</b>	<b>Description</b>
	<b>9.9(0.0)</b>	Introduced on the FN IOM.
	<b>9.4(0.0)</b>	Supported on the FN I/O Aggregator.
	<b>8.3.17.0</b>	Supported on the M I/O Aggregator.

## enable

Change the access privilege level.

**Syntax** `enable [user| admin]`

**Command Modes** uBoot

**Supported Modes** All Modes

<b>Command History</b>	<b>Version</b>	<b>Description</b>
	<b>9.9(0.0)</b>	Introduced on the FN IOM.
	<b>9.4(0.0)</b>	Supported on the FN I/O Aggregator.
	<b>8.3.17.0</b>	Supported on the M I/O Aggregator.

## help

Displays the help menu.

**Syntax** `help`

**Command Modes** uBoot

**Supported Modes** All Modes

<b>Command History</b>	<b>Version</b>	<b>Description</b>
	<b>9.9(0.0)</b>	Introduced on the FN IOM.
	<b>9.4(0.0)</b>	Supported on the FN I/O Aggregator.

Version	Description
8.3.17.0	Supported on the M I/O Aggregator.

### Example

```

BOOT_USER # help
***** Dell Force10 Boot Interface Help Information *****
Current access level: USER LEVEL
Use "syntax help" for more information on syntax.
Available command list (22 commands total):
boot change [primary|secondary|default]
    change operating system boot parameters
boot selection [a|b]
    change the rom bootstrap bootflash partition
boot show net config retries
    show number of retries for network boot config failure
boot write net config retries <int>
    write number of retries for network boot config failure
boot zero [primary|secondary|default]
    zero operating system boot parameters
default-gateway <ip-address>
    default-gateway - set the default gateway ip address
enable [user|admin]
    change access privilege level
help
    display help menu
-(36%)-Use <CR> to continue, q to stop:
BOOT_USER #

```

## ignore enable password

Ignore the enabled password.

**Syntax** ignore enable-password

**Command Modes** uBoot

**Supported Modes** All Modes

Command History	Version	Description
	9.9(0.0)	Introduced on the FN IOM.
	9.4(0.0)	Supported on the FN I/O Aggregator.
	8.3.17.0	Supported on the M I/O Aggregator.

## ignore startup-config

Ignore the system startup configuration.

**Syntax** ignore startup-config

**Command Modes** uBoot

**Supported Modes** All Modes

Command History	Version	Description
	9.9(0.0)	Introduced on the FN IOM.
	9.4(0.0)	Supported on the FN I/O Aggregator.
	8.3.17.0	Supported on the M I/O Aggregator.

# interface management ethernet ip address

Set the management port IP address and mask.

**Syntax** `interface management ethernet ip address <ip/mask>`

**Command Modes** uBoot

**Supported Modes** All Modes

Command History	Version	Description
	<b>9.9(0.0)</b>	Introduced on the FN IOM.
	<b>9.4(0.0)</b>	Supported on the FN I/O Aggregator.
	<b>8.3.17.0</b>	Supported on the M I/O Aggregator.

# no default gateway

Clear the default gateway IP address.

**Syntax** `no default-gateway`

**Command Modes** uBoot

**Supported Modes** All Modes

Command History	Version	Description
	<b>9.9(0.0)</b>	Introduced on the FN IOM.
	<b>9.4(0.0)</b>	Supported on the FN I/O Aggregator.
	<b>8.3.17.0</b>	Supported on the M I/O Aggregator.

# no interface management ethernet ip address

Clear the management port IP address and mask.

**Syntax** `no interface management ethernet ip address`

**Command Modes** uBoot

**Supported Modes** All Modes

Command History	Version	Description
	<b>9.9(0.0)</b>	Introduced on the FN IOM.
	<b>9.4(0.0)</b>	Supported on the FN I/O Aggregator.
	<b>8.3.17.0</b>	Supported on the M I/O Aggregator.

# reload

Reload the switch.

**Syntax** `reload`

**Command Modes** uBoot

**Supported Modes** All Modes

Command History	Version	Description
	<b>9.9(0.0)</b>	Introduced on the FN IOM.
	<b>9.4(0.0)</b>	Supported on the FN I/O Aggregator.
	<b>8.3.17.0</b>	Supported on the M I/O Aggregator.

## show boot blc

Show the boot loop counter value.

**Syntax**                show boot blc

**Command Modes**    uBoot

**Supported Modes** All Modes

Command History	Version	Description
	<b>9.9(0.0)</b>	Introduced on the FN IOM.
	<b>9.4(0.0)</b>	Supported on the FN I/O Aggregator.
	<b>8.3.17.0</b>	Supported on the M I/O Aggregator.

### Example

```

BOOT_USER # show boot blc ?
Total 1 possible command found.
Possible command list:
show boot blc
        show the boot loop counter value
BOOT_USER # show boot blc
Boot Loop Counter : 10

BOOT_USER #

```

## show boot selection

Displays the ROM bootstrap bootflash partition.

**Syntax**                show boot selection

**Command Modes**    uBoot

**Supported Modes** All Modes

Command History	Version	Description
	<b>9.9(0.0)</b>	Introduced on the FN IOM.
	<b>9.4(0.0)</b>	Supported on the FN I/O Aggregator.
	<b>8.3.17.0</b>	Supported on the M I/O Aggregator.

### Example

```

BOOT_USER # show boot blc ?
Total 1 possible command found.
Possible command list:
show boot blc
        show the boot loop counter value
BOOT_USER # show boot blc
Boot Loop Counter : 10

BOOT_USER #

```

# show bootflash

Show the summary of boot flash information.

**Syntax** show bootflash

**Command Modes** uBoot

**Supported Modes** All Modes

Command History	Version	Description
	<b>9.9(0.0)</b>	Introduced on the FN IOM.
	<b>9.4(0.0)</b>	Supported on the FN I/O Aggregator.
	<b>8.3.17.0</b>	Supported on the M I/O Aggregator.

### Example

```
BOOT_USER # show bootflash

GENERAL BOOTFLASH INFO
=====
Bootflash Partition A:
  Dell Force10 Networks System Boot
  Official IOM_LP_IMG_BOOT_LOADER, BSP Release 4.0.1.0bt1
  Created Tue May 1 10:56:16 2012 by build on login-sjc-01

Bootflash Partition B:
  Dell Force10 Networks System Boot
  Official IOM_LP_IMG_BOOT_LOADER, BSP Release 4.0.1.0bt1
  Created Tue May 1 10:56:16 2012 by build on login-sjc-01

Boot Selector Partition:
  Dell Force10 Networks System Boot
  Official IOM_XLOAD_LP_IMG_BOOT_SELECTOR, BSP Release 4.0.0.0bt1
  Created Tue May 1 10:56:34 2012 by build on login-sjc-01

BOOT_USER #
```

# show bootvar

Show the summary of operating system boot parameters.

**Syntax** show bootvar

**Command Modes** uBoot

**Supported Modes** All Modes

Command History	Version	Description
	<b>9.9(0.0)</b>	Introduced on the FN IOM.
	<b>9.4(0.0)</b>	Supported on the FN I/O Aggregator.
	<b>8.3.17.0</b>	Supported on the M I/O Aggregator.

### Example

```
BOOT_USER # show bootvar

PRIMARY OPERATING SYSTEM BOOT PARAMETERS:
=====
boot device           : tftp
file name             : premnath
Management Ethernet IP address : 10.16.130.134/16
Server IP address    : 10.16.127.35
Default Gateway IP address : 15.0.0.1
```

```

Management Ethernet MAC address : 00:01:E8:43:DE:DF

SECONDARY OPERATING SYSTEM BOOT PARAMETERS:
=====
No Operating System boot parameters specified!

DEFAULT OPERATING SYSTEM BOOT PARAMETERS:
=====
boot device                : tftp
file name                  : FTOS-XL-8-3-16-99.bin
Management Ethernet IP address : 10.16.130.134/16
Server IP address         : 10.16.127.53
Default Gateway IP address  : 15.0.0.1
Management Ethernet MAC address : 00:01:E8:43:DE:DF

BOOT_USER #

```

## show default gateway

Displays the default gateway IP address.

**Syntax** `show default-gateway`

**Command Modes** uBoot

**Supported Modes** All Modes

Command History	Version	Description
	<b>9.9(0.0)</b>	Introduced on the FN IOM.
	<b>9.4(0.0)</b>	Supported on the FN I/O Aggregator.
	<b>8.3.17.0</b>	Supported on the M I/O Aggregator.

### Example

```

BOOT_USER # show default-gateway
Gateway IP address: 15.0.0.1
BOOT_USER #

```

## show interface management ethernet

Show the management port IP address and mask.

**Syntax** `show interface management ethernet`

**Command Modes** uBoot

**Supported Modes** All Modes

Command History	Version	Description
	<b>9.9(0.0)</b>	Introduced on the FN IOM.
	<b>9.4(0.0)</b>	Supported on the FN I/O Aggregator.
	<b>8.3.17.0</b>	Supported on the M I/O Aggregator.

### Example

```

BOOT_USER # show interface management ethernet
Management ethernet IP address: 10.16.130.134/16
BOOT_USER #

```



# show interface management port config

Show the management port boot characteristics.

**Syntax** `show interface management port config`

**Command Modes** uBoot

**Supported Modes** All Modes

<b>Command History</b>	<b>Version</b>	<b>Description</b>
	<b>9.9(0.0)</b>	Introduced on the FN IOM.
	<b>9.4(0.0)</b>	Supported on the FN I/O Aggregator.
	<b>8.3.17.0</b>	Supported on the M I/O Aggregator.

## Example

```
BOOT_USER # show interface management port config
Management ethernet Port Configuration: no Auto Negotiate
Management ethernet Port Configuration: 100M
Management ethernet Port Configuration: full duplex
BOOT_USER #
```

# syntax help

Show the syntax information.

**Syntax** `help`

**Command Modes** uBoot

**Supported Modes** All Modes

<b>Command History</b>	<b>Version</b>	<b>Description</b>
	<b>9.9(0.0)</b>	Introduced on the FN IOM.
	<b>9.4(0.0)</b>	Supported on the FN I/O Aggregator.
	<b>8.3.17.0</b>	Supported on the M I/O Aggregator.

# Configuration Cloning

Configuration Cloning enables you to clone the configuration from one aggregator to the other. It identifies a source aggregator where running configuration is check-pointed, extracted and downloaded to the target aggregator for further use. The target aggregator checks the compatibility of the cloning file regarding the mode, port types and optional modules. The target aggregator further takes care of the conflicting configurations and appropriately proceeds with the application of the cloning configuration.

## Topics:

- [clone-config apply](#)
- [clone-config check](#)
- [clone-config create](#)

## clone-config apply

Apply the cloning configuration file on the target aggregator.

**Syntax** `clone-config apply [file-name filename][output xml]`

<b>Parameters</b>	<b>apply</b>	Enter the keyword <code>apply</code> to apply the cloning configuration.
	<b>file-name</b> <b><i>filename</i></b>	Enter the keywords <code>file-name</code> to specify the user-defined cloning configuration file name in flash. By default, the file name is <code>cloning-config</code> .
	<b>output xml</b>	Enter the keywords <code>output xml</code> to enable the command output status to be displayed in the XML format.

**Defaults** `cloning-config`

**Command Modes** EXEC

<b>Command History</b>	<b>Version</b>	<b>Description</b>
	<b>9.10(0.0)</b>	Introduced on the FN IOM and M I/O Aggregator.

## clone-config check

Check the cloning configuration file compatibility with the current configurations on the target aggregator.

**Syntax** `clone-config check [file-name filename][output xml]`

<b>Parameters</b>	<b>check</b>	Enter the keyword <code>check</code> to check the cloning configuration compatibility.
	<b>file-name</b> <b><i>filename</i></b>	Enter the keywords <code>file-name</code> to specify the user-defined cloning configuration file name in flash. By default, the file name is <code>cloning-config</code> .
	<b>output xml</b>	Enter the keywords <code>output xml</code> to enable the command output status to be displayed in the XML format.

**Defaults** `cloning-config`

**Command Modes** EXEC

Command History	Version	Description
	9.10(0.0)	Introduced on the FN IOM and M I/O Aggregator.

## clone-config create

Create the cloning configuration.

**Syntax** `clone-config create [file-name filename][output xml]`

Parameters		
<b>create</b>		Enter the keyword <code>create</code> to create the cloning configuration file.
<b>file-name</b> <b><i>filename</i></b>		Enter the keywords <code>file-name</code> to save the cloning configuration in user-defined filename. By default, it gets stored in flash under the filename <code>cloning-config</code> .
<b>output xml</b>		Enter the keywords <code>output xml</code> to enable the command output status to be displayed in the XML format.

**Defaults** cloning-config

**Command Modes** EXEC

Command History	Version	Description
	9.10(0.0)	Introduced on the FN IOM and M I/O Aggregator.

# Data Center Bridging (DCB)

Data center bridging (DCB) refers to a set of IEEE Ethernet enhancements that provide data centers with a single, robust, converged network to support multiple traffic types, including local area network (LAN), server, and storage traffic. DCB features are auto-configured in standalone mode.

The Dell Networking OS commands for DCB features include 802.1Qbb priority-based flow control (PFC), 802.1Qaz enhanced transmission selection (ETS), and the data center bridging exchange (DCBX) protocol.

CLI commands for individual DCB features are as follows:

## DCB command

- `dcb enable auto-detect on-next-reload`
- `show qos dcb-map`

## PFC Commands

- `clear pfc counters`
- `show interface pfc`
- `show interface pfc statistics`

## ETS Commands

- `clear ets counters`
- `show interface ets`

## DCBX Commands

- `dcbx version`
- `clear dcbx counters`
- `show dcb`
- `show interface dcbx detail`

## Topics:

- [Fibre Channel over Ethernet for FC Flex IO Modules](#)
- `advertise dcbx-appln-tlv`
- `advertise dcbx-tlv`
- `bandwidth-percentage`
- `clear dcbx counters`
- `clear ets counters`
- `clear pfc counters`
- `dcb-enable`
- `dcb enable pfc-queues`
- `dcb enable auto-detect on-next-reload`
- `dcb-map stack-unit all stack-ports all`
- `dcb pfc-shared-buffer-size`
- `dcb pfc-total-buffer-size`
- `dcb-buffer-threshold`
- `dcb-policy buffer-threshold (Global Configuration)`
- `service-class buffer shared-threshold-weight`
- `dcbx-port role`
- `dcbx version`
- `debug dcbx`
- `fc-map`
- `fcoe-map`
- `fcoe priority-bits`
- `iscsi priority-bits`
- `keepalive`

- `interface vlan (NPV proxy gateway)`
- `pfc mode on`
- `pfc no-drop queues`
- `pfc priority`
- `priority-group`
- `priority-group bandwidth pfc`
- `priority-pgid`
- `qos-policy-output ets`
- `scheduler`
- `show dcb`
- `show interface dcbx detail`
- `show interface ets`
- `show interface pfc`
- `show interface pfc statistics`
- `show qos dcb-map`
- `show stack-unit stack-ports ets details`
- `show stack-unit stack-ports pfc details`

## Fibre Channel over Ethernet for FC Flex IO Modules

FCoE provides a converged Ethernet network that allows the combination of storage-area network (SAN) and LAN traffic on a Layer 2 link by encapsulating Fibre Channel data into Ethernet frames.

The Aggregator, installed with the FC Flex IO module, functions as a top-of-rack edge switch that supports converged enhanced Ethernet (CEE) traffic — Fibre channel over Ethernet (FCoE) for storage, Interprocess Communication (IPC) for servers, and Ethernet local area network (LAN) (IP cloud) for data — as well as FC links to one or more storage area network (SAN) fabrics.

FCoE works with the Ethernet enhancements provided in Data Center Bridging (DCB) to support lossless (no-drop) SAN and LAN traffic. In addition, DCB provides flexible bandwidth sharing for different traffic types, such as LAN and SAN, according to 802.1p priority classes of service. DCBx should be enabled on the system before the FIP snooping feature is enabled.

All of the commands that are supported for FCoE on the I/O Aggregator apply to the FC Flex IO modules. Similarly, all of the configuration procedures and the settings that are applicable for FCoE on the I/O Aggregator are valid for the FC Flex IO modules.

## advertise dcbx-appln-tlv

On a DCBX port with a manual role, configure the application priority TLVs advertised on the interface to DCBX peers.

**Syntax** `advertise dcbx-appln-tlv {fcoe | iscsi}`

To remove the application priority TLVs, use the `no advertise dcbx-appln-tlv {fcoe | iscsi}` command.

**Parameters** `{fcoe | iscsi}` Enter the application priority TLVs, where:

- `fcoe`: enables the advertisement of FCoE in application priority TLVs.
- `iscsi`: enables the advertisement of iSCSI in application priority TLVs.

**Defaults** Application priority TLVs are enabled to advertise FCoE and iSCSI.

**Command Modes** PROTOCOL LLDP

**Supported Modes** Programmable-Mux (PMUX)

Command History	Version	Description
	<b>9.9(0.0)</b>	Introduced on the FN IOM.
	<b>9.4(0.0)</b>	Supported on the FN I/O Aggregator.

Version	Description
9.2(0.0)	Introduced on the M I/O Aggregator.
8.3.16.1	Introduced on the MXL 10/40GbE Switch IO Module.

**Usage Information** To disable TLV transmission, use the `no` form of the command; for example, `no advertise dcbx-appln-tlv iscsi`.

## advertise dcbx-tlv

On a DCBX port with a manual role, configure the PFC and ETS TLVs advertised to DCBX peers.

**Syntax** `advertise dcbx-tlv {ets-conf | ets-reco | pfc} [ets-conf | ets-reco | pfc]`  
`[ets-conf | ets-reco | pfc]`

To remove the advertised ETS TLVs, use the `no advertise dcbx-tlv` command.

**Parameters** **{ets-conf | ets-reco | pfc}** Enter the PFC and ETS TLVs advertised, where:

- `ets-conf`: enables the advertisement of ETS configuration TLVs.
- `ets-reco`: enables the advertisement of ETS recommend TLVs.
- `pfc`: enables the advertisement of PFC TLVs.

**Defaults** All PFC and ETS TLVs are advertised.

**Command Modes** PROTOCOL LLDP

**Supported Modes** Programmable-Mux (PMUX)

Command History	Version	Description
	9.9(0.0)	Introduced on the FN IOM.
	9.4(0.0)	Supported on the FN I/O Aggregator.
	9.2(0.0)	Introduced on the M I/O Aggregator.
	8.3.16.1	Introduced on the MXL 10/40GbE Switch IO Module.

**Usage Information** You can configure the transmission of more than one TLV type at a time; for example: `advertise dcbx-tlv ets-conf ets-reco`.

You can enable ETS recommend TLVs (`ets-reco`) only if you enable ETS configuration TLVs (`ets-conf`). To disable TLV transmission, use the `no` form of the command; for example, `no advertise dcbx-tlv pfc ets-reco`.

DCBX requires that you enable LLDP to advertise DCBX TLVs to peers.

Configure DCBX operation at the INTERFACE level on a switch or globally on the switch. To verify the DCBX configuration on a port, use the `show interface dcbx detail` command.

## bandwidth-percentage

Assign a percentage of weight to the class/queue.

**Syntax** `bandwidth-percentage percentage`

To remove the bandwidth percentage, use the `no bandwidth-percentage` command.

**Parameters** **percentage** Enter the percentage assignment of weight to the class/queue. The range is from 1 to 100% (granularity 1%).

**Defaults** none

**Command Modes** CONFIGURATION (conf-qos-policy-out)

**Supported Modes** Programmable-Mux (PMUX)

<b>Command History</b>	<b>Version</b>	<b>Description</b>
	<b>9.9(0.0)</b>	Introduced on the FN IOM.
	<b>9.4(0.0)</b>	Supported on the FN I/O Aggregator.
	<b>9.2(0.0)</b>	Introduced on the M I/O Aggregator.
	<b>8.3.16.1</b>	Introduced on the MXL 10/40GbE Switch IO Module.

**Usage Information** The unit of bandwidth percentage is 1%. A bandwidth percentage of 0 is allowed and disables the scheduling of that class. If the sum of the bandwidth percentages given to all eight classes exceeds 100%, the bandwidth percentage automatically scales down to 100%.

**Related Commands** [qos-policy-output](#) — creates a QoS output policy.

## clear dcbx counters

Clear all DCBx TLV counters on an interface.

**Syntax** `clear dcbx counters tengigabitethernet slot/port`

**Defaults** none

**Command Modes** EXEC Privilege

**Supported Modes** All Modes

<b>Command History</b>	<b>Version</b>	<b>Description</b>
	<b>9.9(0.0)</b>	Introduced on the FN IOM.
	<b>9.4(0.0)</b>	Supported on the FN I/O Aggregator.
	<b>9.2(0.0)</b>	Introduced on the M I/O Aggregator.

## clear ets counters

Clear ETS TLV counters.

**Syntax** `clear ets counters [tengigabitethernet slot/port]`

**Parameters** **slot/port** Enter the slot/port number.

**Command Modes** • EXEC Privilege

**Supported Modes** All Modes

<b>Command History</b>	<b>Version</b>	<b>Description</b>
	<b>9.9(0.0)</b>	Introduced on the FN IOM.
	<b>9.4(0.0)</b>	Supported on the FN I/O Aggregator.
	<b>9.2(0.0)</b>	Introduced on the M I/O Aggregator.

# clear pfc counters

Clear the PFC TLV counters and PFC statistics on an interface or stack unit.

**Syntax** `clear pfc counters [port-type slot/port [statistics]]| [stack-unit {unit-number | all} stack-ports all]`

**Parameters**

- port-type** Enter the keywords `port-type` then the slot/port information.
- stack-unit unit number** Enter the keywords `stack-unit` then the stack-unit number to clear. The range is from 0 to 5.
- all stack-ports all** Enter the keywords `all stack-ports all` to clear the counters on all interfaces.
- statistics** Enter the keyword `statistics` to clear only the hardware PFC counters.

**Defaults** None

**Command Modes** • EXEC Privilege

**Supported Modes** All Modes

Command History	Version	Description
	9.9(0.0)	Introduced on the FN IOM.
	9.4(0.0)	Supported on the FN I/O Aggregator.
	9.2(0.0)	Introduced on the M I/O Aggregator.

**Usage information** If you do not use the `statistics` parameter, both hardware and DCBx counters clear.

# dcb-enable

Enable data center bridging.

**Syntax** `dcb enable`  
To disable DCB, use the `no dcb enable` command.

**Defaults** none

**Command Modes** CONFIGURATION

**Supported Modes** Programmable-Mux (PMUX)

Command History	Version	Description
	9.9(0.0)	Introduced on the FN IOM.
	9.4(0.0)	Supported on the FN I/O Aggregator.
	9.2(0.0)	Introduced on the M I/O Aggregator.

**Usage Information** DCB is not supported if you enable `link-level flow control` on one or more interfaces.

# dcb enable pfc-queues

Configure the number of PFC queues.

**Syntax** `dcb enable pfc-queues value`



**Parameters**      *value*                      Enter the number of PFC queues. The range is from 1 to 4. The number of ports supported based on lossless queues configured will depend on the buffer.

**Default**                      2

**Command Modes**      CONFIGURATION mode

**Supported Modes**      Programmable-Mux (PMUX)

<b>Command History</b>	<b>Version</b>	<b>Description</b>
	<b>9.9(0.0)</b>	Introduced on the FN IOM.
	<b>9.6(0.0)</b>	Supported on the FN 2210S Aggregator.
	<b>9.3(0.0)</b>	Supported on the M I/O Aggregator.
	<b>9.3(0.0)</b>	Supported on the MXL 10/40GbE Switch IO Module platform.

**Usage Information**      You can configure up to a maximum of four lossless (PFC) queues. By configuring four lossless queues, you can configure four different priorities and assign a particular priority to each application that your network is used to process. For example, you can assign a higher priority for time-sensitive applications and a lower priority for other services, such as file transfers. You can configure the amount of buffer space to be allocated for each priority and the pause or resume thresholds for the buffer. This method of configuration enables you to effectively manage and administer the behavior of lossless queues.

**Example**                      Dell(conf)#dcb pfc-queues 4

## dcb enable auto-detect on-next-reload

Enables or disables global DCB on a subsequent reload. Also internally configures PFC buffers based on DCB enable or disable. You must save and reload for the configurations to take effect. You can use the `auto-detect` keyword to re-enable IOA with the port-wise DCB auto detect feature.

**Syntax**                      `dcb enable [auto-detect | on-next-reload]`  
To disable global DCB on a subsequent reload, use the `no dcb enable on-next-reload` command.

**Parameters**

- auto-detect**                      Enter the keywords `auto-detect` to re-enable the Aggregator with port wise DCB auto detect feature.
- on-next-reload**                      Enter the keywords `on-next-reload` to apply DCB configurations on subsequent reload.

**Defaults**                      DCB is globally enabled with auto-detect feature.

**Command Modes**      • CONFIGURATION

**Supported Modes**      All Modes

<b>Command History</b>	<b>Version</b>	<b>Description</b>
	<b>9.9(0.0)</b>	Introduced on the FN IOM.
	<b>9.4(0.0)</b>	Supported on the FN I/O Aggregator.
	<b>8.3.17.3</b>	Added auto-detect parameter on the M I/O Aggregator.
	<b>8.3.17.0</b>	Supported on the M I/O Aggregator.

**Example (Disable)**

```
Dell#show dcb stack-unit 0 port-set 0
stack-unit 0 port-set 0
DCB Status: Enabled, PFC Queue Count: 4

stack-unit Total Buffer PFC Total Buffer PFC Shared Buffer PFC Available Buffer
PP          (KB)      (KB)      (KB)      (KB)
-----
0          3822      1912      832      450
Dell(conf)#
Dell#
Dell#
Dell#conf
```

```

Dell(conf)#no dcb enable on-next-reload
Dell(conf)#end
Dell#
Dell#write memory
!
Mar 18 00:21:49: %STKUNIT0-M:CP %FILEMGR-5-FILESAVED:
  Copied running-config to startup-config in flash by default

Dell#reload

Proceed with reload [confirm yes/no]: y
syncing disks... done
unmounting file systems...
unmounting /f10/flash (/dev/ld0e)...
unmounting /usr (mfs:35)...
unmounting /lib (mfs:24)...
unmounting /f10 (mfs:21)...
unmounting /tmp (mfs:15)...
unmounting /kern (kernfs)...
unmounting / (/dev/md0a)... done
rebooting...

Dell#show dcb stack-unit 0 port-set 0
stack-unit 0 port-set 0
DCB Status: Enabled, PFC Queue Count: 4

stack-unit Total Buffer PFC Total Buffer PFC Shared Buffer PFC Available Buffer
P          (KB)         (KB)         (KB)         (KB)
-----
0          0      3822      1912      832         450
Dell(conf)#
Dell#

```

### Example (Enable)

```

Dell#show dcb stack-unit 0 port-set 0
stack-unit 0 port-set 0
DCB Status: Enabled, PFC Queue Count: 4

stack-unit Total Buffer PFC Total Buffer PFC Shared Buffer PFC Available Buffer
PP         (KB)         (KB)         (KB)         (KB)
-----
0          0      3822      1912      832         450
Dell(conf)#
Dell#
Dell#
Dell#
Dell#conf
Dell(conf)#dcb enable on-next-reload
Dell(conf)#end
Dell#Mar 18 00:26:07: %STKUNIT0-M:CP %SYS-5-CONFIG_I:
  Configured from console

Dell#write memory
!
Mar 18 00:26:11: %STKUNIT0-M:CP %FILEMGR-5-FILESAVED:
  Copied running-config to startup-config in flash by default

Dell#
Dell#reload

Proceed with reload [confirm yes/no]: y
syncing disks... done
unmounting file systems...
unmounting /f10/flash (/dev/ld0e)...
unmounting /usr (mfs:35)...
unmounting /lib (mfs:24)...
unmounting /f10 (mfs:21)...
unmounting /tmp (mfs:15)...
unmounting /kern (kernfs)...
unmounting / (/dev/md0a)... done
rebooting...
Dell#show dcb stack-unit 0 port-set 0
stack-unit 0 port-set 0
DCB Status: Enabled, PFC Queue Count: 4

stack-unit Total Buffer PFC Total Buffer PFC Shared Buffer PFC Available Buffer
PP         (KB)         (KB)         (KB)         (KB)
-----
0          0      3822      1912      832         450
Dell(conf)#

```

### Example (Enable DCB with Auto-Detect)

```

Dell#show dcb
stack-unit 0 port-set 0
DCB Status : Disabled
PFC Queue Count : 2
Total Buffer[lossy + lossless] (in KB) : 3822
PFC Total Buffer (in KB) : 1912
PFC Shared Buffer (in KB) : 832
PFC Available Buffer (in KB) : 1080
Dell#
Dell#
Dell#con
Dell(conf)#dcb enable auto-detect on-next-reload
Dell(conf)#end
Dell#Mar 18 00:35:19: %STKUNIT0-M:CP %SYS-5-CONFIG_I
: Configured from console

Dell#write memory
!
Mar 18 00:35:24: %STKUNIT0-M:CP %FILEMGR-5-FILESAVED:
  Copied running-config to startup-config in flash by default

Dell#
Dell#reload

Proceed with reload [confirm yes/no]: y
syncing disks... done
unmounting file systems...
unmounting /f10/flash (/dev/ld0e)...
unmounting /usr (mfs:35)...
unmounting /lib (mfs:24)...
unmounting /f10 (mfs:21)...
unmounting /tmp (mfs:15)...

```

```

unmounting /kern (kernfs)...
unmounting / (/dev/md0a)... done
rebooting...
Dell#show dcb stack-unit 0 port-set 0
stack-unit 0 port-set 0
DCB Status: Enabled, PFC Queue Count: 4

stack-unit Total Buffer PFC Total Buffer PFC Shared Buffer PFC Available Buffer
PP (KB) (KB) (KB) (KB)
-----
0 0 3822 1912 832 450
Dell (conf) #

```

## dcb-map stack-unit all stack-ports all

Apply the specified DCB map on all ports of the switch stack.

<b>Syntax</b>	<code>dcb-map stack-unit all stack-ports all <i>dcb-map-name</i></code>	
	To remove the PFC and ETS settings in a DCB map from all stack units, use the <code>no dcb-map stack-unit all stack-ports all</code> command.	
<b>Parameters</b>	<b><i>dcb-map-name</i></b>	Enter the name of the DCB map.
<b>Defaults</b>	None	
<b>Command Modes</b>	CONFIGURATION	
<b>Supported Modes</b>	Programmable-Mux (PMUX)	
<b>Command History</b>	<b>Version</b>	<b>Description</b>
	<b>9.9(0.0)</b>	Introduced on the FN IOM.
	<b>9.4(0.0)</b>	Supported on the FN I/O Aggregator.
	<b>9.3(0.0)</b>	Introduced on the FC Flex IO Modules with I/O Aggregator.
<b>Usage Information</b>	The <code>dcb-map stack-unit all stack-ports all</code> command overwrites any previous DCB maps applied to stack ports.	

## dcb pfc-shared-buffer-size

Configure the maximum amount of shared buffer size for PFC packets in kilobytes.

<b>Syntax</b>	<code>dcb pfc-shared-buffer-size <i>KB</i></code>	
<b>Parameters</b>	<b><i>KB</i></b>	Enter a number in the range of 0 to 7787.
<b>Default</b>	None.	
<b>Command Modes</b>	CONFIGURATION mode	
<b>Command History</b>	<b>Version</b>	<b>Description</b>
	<b>9.9(0.0)</b>	Introduced on the M I/O Aggregator and the FN I/O Aggregator.
<b>Usage Information</b>	Configure the maximum shared buffer available for PFC traffic. You can choose to increase or decrease the shared buffer that is allocated in the system by default. Configure the shared buffer size less than the total PFC buffer size. If the buffer size and DCB buffer threshold settings are applied on one or more ports, a validation is performed to determine whether following condition is satisfied: If the shared buffer size is more than the total PFC buffer size value, the configuration is not saved and a system logging message is generated as follows:	

Shared-pfc-buffer-size <= (Total-pfc-buffer-size — Σpfc priority <> buffer-size on each port, priority).

```
Dell(conf)#dcb pfc-shared-buffer-size 2000
%ERROR: pfc shared buffer size configured cannot accommodate existing
buffer requirement in the system.
```

Enter a smaller value for the shared buffer size or increase the total buffer size appropriately by using the `dcb pfc-total- buffer-size` command.

**Example** Dell(conf)#dcb pfc-shared-buffer-size 5000

## dcb pfc-total-buffer-size

Configure the total buffer size for PFC in kilobytes.

**Syntax** dcb pfc-total-buffer-size *KB*

**Parameters** *KB* Enter a number in the range of 0 to 7787.

**Default** The default is 6592KB.

**Command Modes** CONFIGURATION mode

Command History	Version	Description
	9.9(0.0)	Introduced on the M I/O Aggregator and the FN I/O Aggregator.

**Usage Information** Configure the maximum buffer available for PFC traffic. You can choose to increase or decrease the buffer size that is allocated in the system by default. However, if you modify the PFC buffer size lower than the previously configured size, the system determines whether this reduction in size is valid without disrupting the existing configuration. In such a scenario, disable and re-enable DCB. For example, if you modify the total buffer size as 4000 KB from the previous size of 5000 KB, an error message is displayed that this reduction cannot be performed owing to existing system configuration because of queues that are being currently in process.

The lossless queue limit per port is validated based on the `dcb pfc-queues` command. PFC queue configuration identifies the maximum number of queues a port can support. Although the queue limit per port is a baseline when dynamic buffering is enabled, the limit per port for queues depends on the availability of the buffer.

**Example** Dell(conf)#dcb pfc-total-buffer-size 5000

```
Dell(conf)#dcb pfc-total-buffer-size 4000
```

```
%ERROR: Total pfc buffer size configured cannot accommodate existing
buffer requirement in the system.
```

## dcb-buffer-threshold

Configure the profile name for the DCB buffer threshold.

**Syntax** dcb buffer-threshold *profile-name*

**Parameters** *profile-name* Enter the name of the profile, which can be a string of up to 32 characters in length.

**Default** None

**Command Modes** CONFIGURATION mode

<b>Command History</b>	<table border="0"> <thead> <tr> <th style="text-align: left;">Version</th> <th style="text-align: left;">Description</th> </tr> </thead> <tbody> <tr> <td><b>9.9(0.0)</b></td> <td>Introduced on the M I/O Aggregator and the FN I/O Aggregator.</td> </tr> </tbody> </table>	Version	Description	<b>9.9(0.0)</b>	Introduced on the M I/O Aggregator and the FN I/O Aggregator.
Version	Description				
<b>9.9(0.0)</b>	Introduced on the M I/O Aggregator and the FN I/O Aggregator.				
<b>Usage Information</b>	When you enter the profile name, you enter the DCB buffer threshold configuration mode. You can specify the shared buffer threshold limit, the ingress buffer size, buffer limit for pausing the acceptance of packets, and the buffer offset limit for resuming the acceptance of received packets.				
<b>Example</b>	Dell(conf)#dcb buffer-threshold test				
<b>Example of commands in dcb buffer-threshold mode</b>	<pre> qos-policy-buffer queue <i>queue-num</i> pause no-drop queue buffer-size size pause-threshold <i>threshold-value</i> resume-offset <i>threshold-value</i> shared- threshold-weight <i>size</i> </pre> <div style="background-color: #f0f0f0; padding: 5px;"> <pre> Dell(conf)# qos-policy-buffer test Dell(conf-qos-policy-buffer)#queue 0 pause no-drop buffer-size 128000 pause-threshold 103360 resume-threshold 83520 Dell(conf-qos-policy-buffer)# queue 4 pause no-drop buffer-size 128000 pause-threshold 103360 resume-threshold 83520 </pre> </div> <pre> priority value buffer-size <i>size</i> pause-threshold <i>threshold-value</i> resume- offset <i>threshold-value</i> shared-threshold-weight <i>size</i> </pre> <div style="background-color: #f0f0f0; padding: 5px;"> <pre> Dell(conf-dcb-buffer-thr)#priority 0 buffer-size 52 pause-threshold 16 resume-offset 10 shared-threshold-weight 7 </pre> </div>				

## dcb-policy buffer-threshold (Global Configuration)

Assign the dcb buffer threshold policy on the stack ports. To apply the dcb buffer threshold policy on the stack-units, use the configuration mode. To apply on front-end ports, use the interface mode.

**Syntax** `dcb-policy buffer-threshold stack-unit all stack-ports all profile-name`

<b>Parameters</b>	<table border="0"> <tr> <td style="vertical-align: top;"><b>dcb-buffer-threshold</b></td> <td>Configure the profile name for the DCB buffer threshold.</td> </tr> <tr> <td style="vertical-align: top;"><b>profile-name</b></td> <td>Enter the name of the profile, which can be a string of up to 32 characters in length.</td> </tr> <tr> <td style="vertical-align: top;"><b>stack-unit all</b></td> <td>Enter the stack unit identification. Indicates the specific the stack unit or units. Entering all shows the status for all stacks.</td> </tr> <tr> <td style="vertical-align: top;"><b>stack-port all</b></td> <td>Enter the port number of a port in a switch stack.</td> </tr> </table>	<b>dcb-buffer-threshold</b>	Configure the profile name for the DCB buffer threshold.	<b>profile-name</b>	Enter the name of the profile, which can be a string of up to 32 characters in length.	<b>stack-unit all</b>	Enter the stack unit identification. Indicates the specific the stack unit or units. Entering all shows the status for all stacks.	<b>stack-port all</b>	Enter the port number of a port in a switch stack.
<b>dcb-buffer-threshold</b>	Configure the profile name for the DCB buffer threshold.								
<b>profile-name</b>	Enter the name of the profile, which can be a string of up to 32 characters in length.								
<b>stack-unit all</b>	Enter the stack unit identification. Indicates the specific the stack unit or units. Entering all shows the status for all stacks.								
<b>stack-port all</b>	Enter the port number of a port in a switch stack.								

**Default** None

**Command Modes** CONFIGURATION mode

<b>Command History</b>	<table border="0"> <thead> <tr> <th style="text-align: left;">Version</th> <th style="text-align: left;">Description</th> </tr> </thead> <tbody> <tr> <td><b>9.9(0.0)</b></td> <td>Introduced on the M I/O Aggregator and the FN I/O Aggregator.</td> </tr> </tbody> </table>	Version	Description	<b>9.9(0.0)</b>	Introduced on the M I/O Aggregator and the FN I/O Aggregator.
Version	Description				
<b>9.9(0.0)</b>	Introduced on the M I/O Aggregator and the FN I/O Aggregator.				

**Usage Information** You can configure up to a maximum of four lossless (PFC) queues. By configuring four lossless queues, you can configure four different priorities and assign a particular priority to each application that your network is used to process. For example, you can assign a higher priority for time-sensitive applications and a lower priority for other services, such as file transfers. You can configure the amount of buffer space for each priority and the pause or resume thresholds for the buffer. This method of configuration enables you to manage and administer the behavior of lossless queues.

**Example for Configuration Mode** Dell(conf)# dcb-policy buffer-threshold stack-unit all stack-ports all test

## Example for Interface Mode

```
Dell(conf-if-te-1/1)#dcb-policy buffer-threshold test
```

# service-class buffer shared-threshold-weight

Create a service class and associate the threshold weight of the shared buffer with each of the queues per port in the egress direction.

**Syntax**

```
[no] Service-class buffer shared-threshold-weight {[queue0 number] || [queue1 number] || [queue2 number] || [queue3 number] || [queue4 number] || [queue5 number] || [queue6 number] || [queue7 number]}
```

**Parameters**

<b>buffer</b>	Define the shared buffer settings
<b>shared-threshold-weight</b>	Specify the weight of a queue for the shared buffer space
<b>queue 0 to queue 7</b>	To apply the shared-threshold weight, specify the queue number
<b>number</b>	Enter a weight for the queue on the shared buffer as a number in the range of 1 to 11.

**Default** The default threshold weight on the shared buffer for each queue is 9. Therefore, each queue can consume up to 66.67 percent of available shared buffer by default.

**Command Modes** INTERFACE mode

## Command History

Version	Description
9.9(0.0)	Introduced on the M I/O Aggregator and the FN I/O Aggregator.

## Usage Information

You can configure all the data queues. You can configure queues 0-7.

The following table describes the mapping between the threshold weight of the shared buffer on the queue. It also shows the percentage of the available shared buffer used by the queues for each of the corresponding threshold weights of the shared buffer:

shared-threshold-weight on the queue	Description heading
0	No dynamic sharing; shared buffer = 0.
1	0.77%
2	1.54%
3	3.03%
4	5.88%
5	11.11%
6	20%
7	33.33%
8	50%
9	66.67%
10	80%
11	88.89%

## Example

```
Dell(conf-if-te-1/8)#Service-class buffer shared-threshold-weight queue5
4 queue7 6
```

# dcbx-port role

Configure the DCBX port role the interface uses to exchange DCB information.

**Syntax** `dcbx port-role {config-source | auto-downstream | auto-upstream | manual}`  
To remove DCBX port role, use the `no dcbx port-role {config-source | auto-downstream | auto-upstream | manual}` command.

**Parameters**

<b>config-source   auto-downstream   auto-upstream   manual</b>	Enter the DCBX port role, where: <ul style="list-style-type: none"><li>• <code>config-source</code>: configures the port to serve as the configuration source on the switch.</li><li>• <code>auto-upstream</code>: configures the port to receive a peer configuration. The configuration source is elected from auto-upstream ports.</li><li>• <code>auto-downstream</code>: configures the port to accept the internally propagated DCB configuration from a configuration source.</li><li>• <code>manual</code>: configures the port to operate only on administer-configured DCB parameters. The port does not accept a DCB configuration received from a peer or a local configuration source.</li></ul>
---	---

**Defaults** **Manual**

**Command Modes** INTERFACE PROTOCOL LLDP

**Supported Modes** Programmable-Mux (PMUX)

Command History	Version	Description
	<b>9.9(0.0)</b>	Introduced on the FN IOM.
	<b>9.4(0.0)</b>	Supported on the FN I/O Aggregator.
	<b>9.3(0.0)</b>	Introduced on the FC Flex IO module installed in the M I/O Aggregator.

**Usage Information**

DCBX requires that you enable LLDP to advertise DCBX TLVs to peers.

Configure DCBX operation at the INTERFACE level on a switch or globally on the switch. To verify the DCBX configuration on a port, use the `show interface dcbx detail` command.

# dcbx version

Configure the DCBX version used on the interface.

**Syntax** `dcbx version {auto | cee | cin | ieee-v2.5}`  
To remove the DCBX version, use the `no dcbx version {auto | cee | cin | ieee-v2.5}` command.

**Parameters**

<b>auto   cee   cin   ieee-v2.5</b>	Enter the DCBX version type used on the interface, where: <ul style="list-style-type: none"><li>• <code>auto</code>: configures the port to operate using the DCBX version received from a peer.</li><li>• <code>cee</code>: configures the port to use CEE (Intel 1.01).</li><li>• <code>cin</code>: configures the port to use Cisco-Intel-Nuova (DCBX 1.0).</li><li>• <code>ieee-v2.5</code>: configures the port to use IEEE 802.1az (Draft 2.5).</li></ul>
-------------------------------------	---

**Defaults** **Auto**

**Command Modes** INTERFACE PROTOCOL LLDP

**Supported Modes** All Modes

Command History	Version	Description
	<b>9.9(0.0)</b>	Introduced on the FN IOM.
	<b>9.4(0.0)</b>	Supported on the FN I/O Aggregator.
	<b>9.3(0.0)</b>	Introduced on the FC Flex IO module installed in the M I/O Aggregator.

**Usage Information** DCBX requires that you enable LLDP to advertise DCBX TLVs to peers.  
Configure DCBX operation at the INTERFACE level on a switch or globally on the switch. To verify the DCBX configuration on a port, use the `show interface dcbx detail` command.

## debug dcbx

Enable DCBX debugging.

**Syntax** `debug dcbx {all | auto-detect-timer | config-exchng | fail | mgmt | resource | sem | tlv}`

To disable DCBX debugging, use the `no debug dcbx` command.

**Parameters** `{all | auto-detect-timer | config-exchng | fail | mgmt | resource | sem | tlv}`

Enter the type of debugging, where:

- `all`: enables all DCBX debugging operations.
- `auto-detect-timer`: enables traces for DCBX auto-detect timers.
- `config-exchng`: enables traces for DCBX configuration exchanges.
- `fail`: enables traces for DCBX failures.
- `mgmt`: enables traces for DCBX management frames.
- `resource`: enables traces for DCBX system resource frames.
- `sem`: enables traces for the DCBX state machine.
- `tlv`: enables traces for DCBX TLVs.

**Defaults** none

**Command Modes** EXEC Privilege

**Supported Modes** Programmable-Mux (PMUX)

Command History	Version	Description
	<b>9.9(0.0)</b>	Introduced on the FN IOM.
	<b>9.4(0.0)</b>	Supported on the FN I/O Aggregator.
	<b>9.3(0.0)</b>	Introduced on the FC Flex IO module installed in the M I/O Aggregator.

## fc-map

In an FCoE map, configure the FCoE mapped address prefix (FC-MAP) value which is used to identify FCoE traffic transmitted on the FCoE VLAN for the specified fabric.

**Syntax** `fc-map fc-map-value`

**Parameters** `fc-map-value`

Enter the unique MAC address prefix used by a SAN fabric.  
The range of FC-MAP values is from 0EFC00 to 0EFCFF.

**Defaults** None



**Command Modes** FCoE MAP

**Supported Modes** Programmable-Mux (PMUX)

<b>Command History</b>	<b>Version</b>	<b>Description</b>
	<b>9.9(0.0)</b>	Introduced on the FN IOM.
	<b>9.6(0.0)</b>	Supported on the FN 2210S Aggregator.
	<b>9.3(0.0)</b>	Introduced on the M I/O Aggregator and MXL 10/40GbE Switch with the FC Flex IO module.

**Usage Information**

The FC-MAP value you enter must match the FC-MAP value used by an FC switch or FCoE forwarder (FCF) in the fabric. An FCF switch accepts only FCoE traffic that uses the correct FC-MAP value.

The FC-MAP value is used to generate the fabric-provided MAC address (FP-MAC). The FPMA is used by servers to transmit FCoE traffic to the fabric. An FC-MAP can be associated with only one FCoE VLAN and vice versa.

In an FCoE map, the FC-MAP value, fabric ID, and FCoE VLAN parameters must be unique.

To remove a configured FC-MAP value from an FCoE map, enter the `no fcoe-map` command.

**Related Commands** [fcoe-map](#) — creates an FCoE map which contains the parameters used in the communication between servers and a SAN fabric.

## fcoe-map

Create an FCoE map which contains the parameters used to configure the links between server CNAs and a SAN fabric. Apply the FCoE map on a server-facing Ethernet port.

**Syntax** `fcoe-map map-name`

**Parameters** **map-name** Maximum: 32 alphanumeric characters.

**Defaults** On the FN2210S Aggregator with PMUX modules, the following parameters are applied on all the PMUX module interfaces:

- Description: SAN\_FABRIC
- Fabric-id: 1002
- Fcoe-vlan: 1002
- Fc-map: 0x0efc00
- Fcf-priority: 128
- Fka-adv-period: 8000mSec
- Keepalive: enable
- Vlan priority: 3

**Command Modes** CONFIGURATION  
INTERFACE

**Supported Modes** Programmable-Mux (PMUX)

<b>Command History</b>	<b>Version</b>	<b>Description</b>
	<b>9.9(0.0)</b>	Introduced on the FN IOM.
	<b>9.6(0.0)</b>	Supported on the FN2210S Aggregator.
	<b>9.3(0.0)</b>	Introduced on the M I/O Aggregator.

## Usage Information

An FCoE map is a template used to map FCoE and FC parameters in a converged fabric. An FCoE map is used to virtualize upstream FC ports on an FN2210S Aggregator with the PMUX module NPIV proxy gateway so that they appear to downstream server CNA ports as FCoE forwarder (FCF) ports on an FCoE network. When applied to FC and Ethernet ports on an NPIV proxy gateway, an FCoE map allows the switch to operate as an FCoE-FC bridge between an FC SAN and an FCoE network by providing FCoE-enabled servers and switches with the necessary parameters to log in to a SAN fabric.

On an FN2210S Aggregator with the PMUX module NPIV proxy gateway, you cannot apply an FCoE map applied on fabric-facing FC ports and server-facing 10-Gigabit Ethernet ports.

An FCoE map consists of the following parameters: the dedicated FCoE VLAN used for storage traffic, the destination SAN fabric (FC-MAP value), FCF priority used by a server, and the FIP keepalive (FKA) advertisement timeout.

In each FCoE map, the fabric ID, FC-MAP value, and FCoE VLAN parameters must be unique. Use one FCoE map to access one SAN fabric. You cannot use the same FCoE map to access different fabrics.

To remove an FCoE map from an Ethernet interface, enter the `no fcoe-map map-name` command in Interface configuration mode.

## fcoe priority-bits

Configure the FCoE priority advertised for the FCoE protocol in application priority TLVs.

**Syntax** `fcoe priority-bits priority-bitmap`  
To remove the configured FCoE priority, use the `no fcoe priority-bits` command.

**Parameters** *priority-bitmap* Enter the priority-bitmap range. The range is from 1 to FF.

**Defaults** 0x8

**Command Modes** PROTOCOL LLDP

**Supported Modes** Programmable-Mux (PMUX)

Command History	Version	Description
	<b>9.9(0.0)</b>	Introduced on the FN IOM.
	<b>9.4(0.0)</b>	Supported on the FN I/O Aggregator.
	<b>9.3(0.0)</b>	Introduced on the FC Flex IO module installed in the M I/O Aggregator.

**Usage Information** This command is available at the global level only.

## iscsi priority-bits

Configure the iSCSI priority advertised for the iSCSI protocol in application priority TLVs.

**Syntax** `iscsi priority-bits priority-bitmap`  
To remove the configured iSCSI priority, use the `no iscsi priority-bits` command.

**Parameters** *priority-bitmap* Enter the priority-bitmap range. The range is from 1 to FF.

**Defaults** 0x10

**Command Modes** PROTOCOL LLDP

**Supported Modes** Programmable-Mux (PMUX)

Command History	Version	Description
	<b>9.9(0.0)</b>	Introduced on the FN IOM.
	<b>9.4(0.0)</b>	Supported on the FN I/O Aggregator.
	<b>9.3(0.0)</b>	Introduced on the FC Flex IO module installed in the M I/O Aggregator.

**Usage Information** This command is available at the global level only.

## keepalive

Send keepalive packets periodically to keep an interface alive when it is not transmitting data.

**Syntax** `keepalive [seconds]`  
To stop sending keepalive packets, use the `no keepalive` command.

**Parameters** **seconds** (OPTIONAL) For interfaces with PPP encapsulation enabled, enter the number of seconds between keepalive packets. The range is from 0 to 23767. The default is **10 seconds**.

**Defaults** Enabled.

**Command Modes** INTERFACE

**Supported Modes** Programmable-Mux (PMUX)

Command History	Version	Description
	<b>9.9(0.0)</b>	Introduced on the FN IOM.
	<b>9.4(0.0)</b>	Supported on the FN I/O Aggregator.
	<b>8.3.17.0</b>	Introduced on the M I/O Aggregator.

**Usage Information** When you configure `keepalive`, the system sends a self-addressed packet out of the configured interface to verify that the far end of a WAN link is up. When you configure `no keepalive`, the system does not send keepalive packets and so the local end of a WAN link remains up even if the remote end is down.

## interface vlan (NPIV proxy gateway)

Create a dedicated VLAN to be used to send and receive Fibre Channel traffic over FCoE links between servers and a fabric over an Aggregator with the PMUX module of NPIV proxy gateway.

**Syntax** `interface vlan vlan-id`

**Parameters** **vlan-id** Enter a number as the VLAN Identifier. The range is 1 to 4094.

**Defaults** Not configured.

**Command Modes** CONFIGURATION

**Supported Modes** Programmable-Mux (PMUX)

Command History	Version	Description
	<b>9.9(0.0)</b>	Introduced on the FN IOM.
	<b>9.4(0.0)</b>	Introduced on the FN I/O Aggregator.
	<b>9.3(0.0)</b>	Introduced on the M I/O Aggregator.

## Usage Information

FCoE storage traffic received from servers on an M I/O Aggregator with the PMUX module NPIV proxy gateway is de-capsulated into Fibre Channel packets and forwarded over FC links to SAN switches in a specified fabric. You must configure a separate FCoE VLAN for each fabric to which FCoE traffic is forwarded. Any non-FCoE traffic sent on a dedicated FCoE VLAN will be dropped.

You configure the association between a dedicated VLAN, which carries FCoE traffic from server CNAs over the NPIV proxy gateway to a SAN fabric in which destination storage arrays are installed, in an FCoE map by using the `fabric id vlan` command.

When you apply an FCoE map to a server-facing Ethernet port, the port is automatically configured as a tagged member of the FCoE VLAN.

For more information about VLANs and the commands to configure them, refer to the [Virtual LAN \(VLAN\) Commands](#) section.

## Example (Single Range)

```
Dell(conf)#interface vlan 10
Dell(conf-if-vl-3)#
```

## Related Commands

`fcoe-map` — creates an FCoE map which contains the parameters used in the communication between servers and a SAN fabric.

# pfc mode on

Enable the PFC configuration on the port so that the priorities are included in DCBX negotiation with peer PFC devices.

**Syntax** `pfc mode on`

To disable the PFC configuration, use the `no pfc mode on` command.

**Defaults** PFC mode is on.

**Command Modes** DCB MAP

**Supported Modes** Programmable-Mux (PMUX)

## Command History

Version	Description
<b>9.9(0.0)</b>	Introduced on the FN IOM.
<b>9.4(0.0)</b>	Introduced on the FN I/O Aggregator.
<b>9.2(0.0)</b>	Introduced on the M I/O Aggregator.

## Usage Information

By applying a DCB input policy with PFC enabled, you enable PFC operation on ingress port traffic. To achieve complete lossless handling of traffic, also enable PFC on all DCB egress ports or configure the dot1p priority-queue assignment of PFC priorities to lossless queues (refer to `pfc no-drop queues`).

To disable PFC operation on an interface, enter the `no pfc mode on` command in DCB Input Policy Configuration mode. PFC is enabled and disabled as global DCB operation is enabled (`dcb-enable`) or disabled (`no dcb-enable`).

You cannot enable PFC and link-level flow control at the same time on an interface.

# pfc no-drop queues

Configure the port queues that still function as no-drop queues for lossless traffic.

**Syntax** `pfc no-drop queues queue-range`

To remove the no-drop port queues, use the `no pfc no-drop queues` command.

**Parameters** *queue-range* Enter the queue range. Separate the queue values with a comma; specify a priority range with a dash; for example, `pfc no-drop queues 1,3` or `pfc no-drop queues 2-3`. The range is from 0 to 3.

**Defaults** No lossless queues are configured.

**Command Modes** INTERFACE

**Supported Modes** Programmable-Mux (PMUX)

Command History	Version	Description
	<b>9.9(0.0)</b>	Introduced on the FN IOM.
	<b>9.4(0.0)</b>	Supported on the FN I/O Aggregator.
	<b>9.2(0.0)</b>	Introduced on the M I/O Aggregator.
	<b>8.3.16.1</b>	Introduced on the MXL 10/40GbE Switch IO Module.

**Usage Information** The maximum number of lossless queues globally supported on the switch is two. The following lists the dot1p priority-queue assignments.

dot1p Value in the Incoming Frame	Description heading
0	0
1	0
2	0
3	1
4	2
5	3
6	3
7	3

## pfc priority

Configure the CoS traffic to be stopped for the specified delay.

**Syntax** `pfc priority priority-range`  
To delete the pfc priority configuration, use the `no pfc priority` command.

**Parameters** *priority-range* Enter the 802.1p values of the frames to be paused. Separate the priority values with a comma; specify a priority range with a dash; for example, `pfc priority 1,3,5-7`. The range is from 0 to 7.

**Defaults** none

**Command Modes** Interface

**Supported Modes** Programmable-Mux (PMUX)

Command History	Version	Description
	<b>9.4(0.0)</b>	Supported on the FN I/O Aggregator.
	<b>9.2(0.0)</b>	Introduced on the M I/O Aggregator.
	<b>8.3.16.1</b>	Introduced on the MXL 10/40GbE Switch IO Module.

## Usage Information

You can enable any number of 802.1p priorities for PFC. Queues to which PFC priority traffic is mapped are lossless by default. Traffic may be interrupted due to an interface flap (going down and coming up) when you reconfigure the lossless queues for no-drop priorities in a PFC input policy and reapply the policy to an interface.

The maximum number of lossless queues supported on the I/O Aggregator switch is four.

A PFC peer must support the configured priority traffic (as DCBX detects) to apply PFC.

# priority-group

To use with an ETS output policy, create an ETS priority group.

## Syntax

```
priority-group group-name
```

To remove the priority group, use the `no priority-group` command.

## Parameters

**group-name** Enter the name of the ETS priority group. The maximum is 32 characters.

## Defaults

none

**Command Modes** CONFIGURATION

**Supported Modes** Programmable-Mux (PMUX)

## Command History

### Version

### Description

**9.4(0.0)**

Supported on the FN I/O Aggregator.

**9.2(0.0)**

Introduced on the M I/O Aggregator.

**8.3.16.1**

Introduced on the MXL 10/40GbE Switch IO Module.

## Usage Information

A priority group consists of 802.1p priority values that are grouped for similar bandwidth allocation and scheduling, and that share latency and loss requirements. All 802.1p priorities mapped to the same queue must be in the same priority group.

You must configure 802.1p priorities in priority groups associated with an ETS output policy. You can assign each dot1p priority to only one priority group.

The maximum number of priority groups supported in ETS output policies on an interface is equal to the number of data queues (4) on the port. The 802.1p priorities in a priority group can map to multiple queues.

If you configure more than one priority queue as strict priority or more than one priority group as strict priority, the higher numbered priority queue is given preference when scheduling data traffic.

# priority-group bandwidth pfc

Configure the ETS bandwidth allocation and PFC mode used to manage port traffic in an 802.1p priority group.

## Syntax

```
priority-group group-num {bandwidth percentage| strict-priority} pfc {on | off}
```

## Parameters

**priority-group group-num**

Enter the keyword `priority-group` followed by the number of an 802.1p priority group. Use the `priority-pgid` command to create the priority groups in a DCB map.

**bandwidth percentage**

Enter the keyword `bandwidth` followed by a bandwidth percentage allocated to the priority group. The range of valid values is 1 to 100. The sum of all allocated bandwidth percentages in priority groups in a DCB map must be 100%.

<b>strict-priority</b>	Configure the priority-group traffic to be handled with strict priority scheduling. Strict-priority traffic is serviced first, before bandwidth allocated to other priority groups is made available.
<b>pfc {on   off}</b>	Configure whether priority-based flow control is enabled (on) or disabled (off) for port traffic in the priority group.

**Defaults** None

**Command Modes** DCB MAP

**Supported Modes** Programmable-Mux (PMUX)

<b>Command History</b>	<b>Version</b>	<b>Description</b>
	<b>9.9(0.0)</b>	Introduced on the FN IOM.
	<b>9.4(0.0)</b>	Supported on the FN I/O Aggregator.
	<b>9.3(0.0)</b>	Introduced on the FC Flex IO module installed in the M I/O Aggregator.

**Usage Information** Use the `dcb-map` command to configure priority groups with PFC and/or ETS settings and apply them to Ethernet interfaces.

Use the `priority-pgid` command to map 802.1p priorities to a priority group. You can assign each 802.1p priority to only one priority group. A priority group consists of 802.1p priority values that are grouped together for similar bandwidth allocation and scheduling, and that share latency and loss requirements. All 802.1p priorities mapped to the same queue must be in the same priority group.

Repeat the `priority-group bandwidth pfc` command to configure PFC and ETS traffic handling for each priority group in a DCB map.

You can enable PFC on a maximum of two priority queues.

If you configure more than one priority group as strict priority, the higher numbered priority queue is given preference when scheduling data traffic.

If a priority group does not use its allocated bandwidth, the unused bandwidth is made available to other priority groups.

To remove a priority-group configuration in a DCB map, enter the `no priority-group bandwidth pfc` command.

By default, equal bandwidth is assigned to each dot1p priority in a priority group. Use the `bandwidth` parameter to configure the bandwidth percentage assigned to a priority group. The sum of the bandwidth allocated to all priority groups in a DCB map must be 100% of the bandwidth on the link. You must allocate at least 1% of the total port bandwidth to each priority group.

**Related Commands** [priority-pgid](#) – Configures the 802.1p priority traffic in a priority group for a DCB map.

## priority-pgid

Assign 802.1p priority traffic to a priority group in a DCB map.

**Syntax** `priority-pgid dot1p0_group-num dot1p1_group-num dot1p2_group-num dot1p3_group-num dot1p4_group-num dot1p5_group-num dot1p6_group-num dot1p7_group-num`

**Parameters**

- `dot1p0_group-num`** Enter the priority group number for each 802.1p class of traffic in a DCB map.
- `dot1p1_group-num`**
- `dot1p2_group-num`**

***dot1p3\_group-num***

***dot1p4\_group-num***

***dot1p5\_group-num***

***dot1p6\_group-num***

***dot1p7\_group-num***

**Defaults** None

**Command Modes** DCB MAP

**Supported Modes** Programmable-Mux (PMUX)

<b>Command History</b>	<b>Version</b>	<b>Description</b>
	<b>9.9(0.0)</b>	Introduced on the FN IOM.
	<b>9.4(0.0)</b>	Supported on the FN I/O Aggregator.
	<b>9.3(0.0)</b>	Introduced on the FC Flex IO module installed in the M I/O Aggregator.

**Usage Information** PFC and ETS settings are not pre-configured on Ethernet ports. You must use the `dcb-map` command to configure different groups of 802.1p priorities with PFC and ETS settings.

Using the `priority-pgid` command, you assign each 802.1p priority to one priority group. A priority group consists of 802.1p priority values that are grouped together for similar bandwidth allocation and scheduling, and that share latency and loss requirements. All 802.1p priorities mapped to the same queue must be in the same priority group. For example, the `priority-pgid 0 0 0 1 2 4 4 4` command creates the following groups of 802.1p priority traffic:

- Priority group 0 contains traffic with dot1p priorities 0, 1, and 2.
- Priority group 1 contains traffic with dot1p priority 3.
- Priority group 2 contains traffic with dot1p priority 4.
- Priority group 4 contains traffic with dot1p priority 5, 6, and 7.

To remove a `priority-pgid` configuration from a DCB map, enter the `no priority-pgid` command.

**Related Commands** [priority-group bandwidth pfc](#)— Configures the ETS bandwidth allocation and the PFC setting used to manage the port traffic in an 802.1p priority group.

## qos-policy-output ets

To configure the ETS bandwidth allocation and scheduling for priority traffic, create a QoS output policy.

**Syntax** `qos-policy-output policy-name ets`

To remove the QoS output policy, use the `no qos-policy-output ets` command.

**Parameters** ***policy-name*** Enter the policy name. The maximum is 32 characters.

**Command Modes** CONFIGURATION

**Supported Modes** All Modes

<b>Command History</b>	<b>Version</b>	<b>Description</b>
	<b>9.9(0.0)</b>	Introduced on the FN IOM.



Version	Description
9.4(0.0)	Supported on the FN I/O Aggregator.
9.2(0.0)	Introduced on the M I/O Aggregator.
8.3.16.1	Introduced on the MXL 10/40GbE Switch IO Module.

### Usage Information

If an error occurs in an ETS output-policy configuration, the configuration is ignored and the scheduler and bandwidth allocation settings are reset to the ETS default values (all priorities are in the same ETS priority group and bandwidth is allocated equally to each priority).

If an error occurs when a port receives a peer's ETS configuration, the port's configuration is reset to the previously configured ETS output policy. If no ETS output policy was previously applied, the port is reset to the default ETS parameters.

### Related Commands

- [scheduler](#) — schedules the priority traffic in port queues.
- [bandwidth-percentage](#) — bandwidth percentage allocated to the priority traffic in port queues.

## scheduler

Configure the method used to schedule priority traffic in port queues.

### Syntax

`scheduler value`

To remove the configured priority schedule, use the `no scheduler` command.

### Parameters

**value**

Enter schedule priority value. The valid values are:

- `strict`: strict-priority traffic is serviced before any other queued traffic.
- `werr`: weighted elastic round robin (werr) provides low-latency scheduling for priority traffic on port queues.

### Defaults

Weighted elastic round robin (WERR) scheduling is used to queue priority traffic.

### Command Modes

POLICY-MAP-OUT-ETS

### Supported Modes

Programmable-Mux (PMUX)

### Command History

Version	Description
9.9(0.0)	Introduced on the FN IOM.
9.4(0.0)	Supported on the FN I/O Aggregator.
9.2(0.0)	Introduced on the M I/O Aggregator.
8.3.16.1	Introduced on the MXL 10/40GbE Switch IO Module.

### Usage Information

dot1p priority traffic on the switch is scheduled to the current queue mapping. dot1p priorities within the same queue must have the same traffic properties and scheduling method.

ETS-assigned scheduling applies only to data queues, not to control queues.

The configuration of bandwidth allocation and strict-queue scheduling is not supported at the same time for a priority group. If you configure both, the configured bandwidth allocation is ignored for priority-group traffic when you apply the output policy on an interface.

### Related Commands

- [bandwidth-percentage](#) — bandwidth percentage allocated to priority traffic in port queues.

# show dcb

Displays the data center bridging status, the number of PFC-enabled ports, and the number of PFC-enabled queues.

**Syntax** `show dcb [stack-unit unit-number]`

**Parameters** *unit number* Enter the DCB unit number. The range is from 0 to 5.

**Command Modes** EXEC Privilege

**Supported Modes** All Modes

Command History	Version	Description
	<b>9.9(0.0)</b>	Introduced on the FN IOM.
	<b>9.4(0.0)</b>	Supported on the FN I/O Aggregator.
	<b>9.2(0.0)</b>	Introduced on the M I/O Aggregator.
	<b>8.3.16.1</b>	Introduced on the MXL 10/40GbE Switch IO Module.

**Usage Information** Specify a stack-unit number on the Master switch in a stack.

## Example

```
Dell#show dcb
stack-unit 0 port-set 0
DCB Status : Enabled
PFC Queue Count : 2
Total Buffer[lossy + lossless] (in KB) : 3822
PFC Total Buffer (in KB) : 1912
PFC Shared Buffer (in KB) : 832
PFC Available Buffer (in KB) : 1080
```

# show interface dcbx detail

Displays the DCBX configuration on an interface.

**Syntax** `show interface port-type slot/port dcbx detail`

**Parameters** *port-type* Enter the port type.

*slot/port* Enter the slot/port number.

- NOTE:** This command also enables you to view information corresponding to a range of ports.
- You can specify multiple ports as *slot/port-range*. For example, if you want to display information corresponding to all ports between 1 and 4, specify the port range as `show interfaces interface-type 1/1 - 4`.

**Command Modes** CONFIGURATION

**Supported Modes** All Modes

Command History	Version	Description
	<b>9.9(0.0)</b>	Introduced on the FN IOM and added support to display the interface configurations corresponding to a range of ports.
	<b>9.4(0.0)</b>	Supported on the FN I/O Aggregator.
	<b>9.2(0.0)</b>	Introduced on the M I/O Aggregator.
	<b>8.3.16.1</b>	Introduced on the MXL 10/40GbE Switch IO Module.

## Usage Information

To clear DCBX frame counters, use the `clear dcbx counters interface stack-unit/port` command.

The following describes the `show interface dcbx detail` command shown in the following example.

Field	Description
<b>Interface</b>	Interface type with chassis slot and port number.
<b>Port-Role</b>	Configured the DCBX port role: auto-upstream, auto-downstream, config-source, or manual.
<b>DCBX Operational Status</b>	Operational status (enabled or disabled) used to elect a configuration source and internally propagate a DCB configuration. The DCBX operational status is the combination of PFC and ETS operational status.
<b>Configuration Source</b>	Specifies whether the port serves as the DCBX configuration source on the switch: true (yes) or false (no).
<b>Local DCBX Compatibility mode</b>	DCBX version accepted in a DCB configuration as compatible. In auto-upstream mode, a port can only receive a DCBX version supported on the remote peer.
<b>Local DCBX Configured mode</b>	DCBX version configured on the port: CEE, CIN, IEEE v2.5, or Auto (port auto-configures to use the DCBX version received from a peer).
<b>Peer Operating version</b>	DCBX version that the peer uses to exchange DCB parameters.
<b>Local DCBX TLVs Transmitted</b>	Transmission status (enabled or disabled) of advertised DCB TLVs (see TLV code at the top of the show command output).
<b>Local DCBX Status: DCBX Operational Version</b>	DCBX version advertised in Control TLVs.
<b>Local DCBX Status: DCBX Max Version Supported</b>	Highest DCBX version supported in Control TLVs.
<b>Local DCBX Status: Sequence Number</b>	Sequence number transmitted in Control TLVs.
<b>Local DCBX Status: Acknowledgment Number</b>	Acknowledgement number transmitted in Control TLVs.
<b>Local DCBX Status: Protocol State</b>	Current operational state of the DCBX protocol: ACK or IN-SYNC.
<b>Peer DCBX Status: DCBX Operational Version</b>	DCBX version advertised in Control TLVs received from the peer device.
<b>Peer DCBX Status: DCBX Max Version Supported</b>	Highest DCBX version supported in Control TLVs received from the peer device.
<b>Peer DCBX Status: Sequence Number</b>	Sequence number transmitted in Control TLVs received from the peer device.

Field	Description
<b>Peer DCBX Status: Acknowledgment Number</b>	Acknowledgement number transmitted in Control TLVs received from the peer device.
<b>Total DCBX Frames transmitted</b>	Number of DCBX frames sent from the local port.
<b>Total DCBX Frames received</b>	Number of DCBX frames received from the remote peer port.
<b>Total DCBX Frame errors</b>	Number of DCBX frames with errors received.
<b>Total DCBX Frames unrecognized</b>	Number of unrecognizable DCBX frames received.

### Example

```

Dell(conf)# show interface tengigabitethernet 0/49 dcbx detail
Dell#show interface te 0/49 dcbx detail

E-ETS Configuration TLV enabled
  e-ETS Configuration TLV disabled
R-ETS Recommendation TLV enabled
  r-ETS Recommendation TLV disabled
P-PFC Configuration TLV enabled
  p-PFC Configuration TLV disabled
F-Application priority for FCOE enabled
  f-Application Priority for FCOE disabled
I-Application priority for iSCSI enabled
  i-Application Priority for iSCSI disabled
-----

Interface TenGigabitEthernet 0/49
  Remote Mac Address 00:00:00:00:00:11
  Port Role is Auto-Upstream
  DCBX Operational Status is Enabled
  Is Configuration Source? TRUE

Local DCBX Compatibility mode is CEE
Local DCBX Configured mode is CEE
Peer Operating version is CEE
Local DCBX TLVs Transmitted: ErPfi

Local DCBX Status
-----
  DCBX Operational Version is 0
  DCBX Max Version Supported is 0
  Sequence Number: 2
  Acknowledgment Number: 2
  Protocol State: In-Sync

Peer DCBX Status:
-----
  DCBX Operational Version is 0
  DCBX Max Version Supported is 255
  Sequence Number: 2
  Acknowledgment Number: 2
  Total DCBX Frames transmitted 27
  Total DCBX Frames received 6
  Total DCBX Frame errors 0
  Total DCBX Frames unrecognized 0

```

# show interface ets

Displays the ETS configuration applied to egress traffic on an interface, including priority groups with priorities and bandwidth allocation.

**Syntax** `show interface port-type slot/port ets {summary | detail}`

**Parameters**

<b><i>port-type slot/port ets</i></b>	Enter the port-type slot and port ETS information.
<b>{summary   detail}</b>	Enter the keyword <code>summary</code> for a summary list of results or enter the keyword <code>detail</code> for a full list of results.

**NOTE:** This command also enables you to view information corresponding to a range of ports.

- You can specify multiple ports as `slot/port-range`. For example, if you want to display information corresponding to all ports between 1 and 4, specify the port range as `show interfaces interface-type 1/1 - 4`.

**Command Modes** CONFIGURATION

**Supported Modes** All Modes

Command History	Version	Description
	<b>9.9(0.0)</b>	Introduced on the FN IOM and added support to display the interface configurations corresponding to a range of ports.
	<b>9.4(0.0)</b>	Supported on the FN I/O Aggregator.
	<b>9.2(0.0)</b>	Introduced on the M I/O Aggregator.
	<b>8.3.16.1</b>	Introduced on the MXL 10/40GbE Switch IO Module.

**Usage Information** To clear ETS TLV counters, use the `clear ets counters interface port-type slot/port` command.

The following describes the `show interface summary` command shown in the following example.

Field	Description
<b>Interface</b>	Interface type with stack-unit and port number.
<b>Max Supported TC Group</b>	Maximum number of priority groups supported.
<b>Number of Traffic Classes</b>	Number of 802.1p priorities currently configured.
<b>Admin mode</b>	ETS mode: on or off. When on, the scheduling and bandwidth allocation configured in an ETS output policy or received in a DCBX TLV from a peer can take effect on an interface.
<b>Admin Parameters</b>	ETS configuration on local port, including priority groups, assigned dot1p priorities, and bandwidth allocation.
<b>Remote Parameters</b>	ETS configuration on remote peer port, including admin mode (enabled if a valid TLV was received or disabled), priority groups, assigned dot1p priorities, and bandwidth allocation. If ETS admin mode is enabled on the remote port for DCBX exchange, the Willing bit received in ETS TLVs from the remote peer is included.
<b>Local Parameters</b>	ETS configuration on local port, including admin mode (enabled when a valid TLV is received from a peer), priority groups, assigned dot1p priorities, and bandwidth allocation.
<b>Operational status (local port)</b>	Port state for current operational ETS configuration: <ul style="list-style-type: none"><li><code>Init</code>: Local ETS configuration parameters were exchanged with the peer.</li><li><code>Recommend</code>: Remote ETS configuration parameters were received from the peer.</li></ul>

Field	Description
	<ul style="list-style-type: none"> <li>Internally propagated: ETS configuration parameters were received from the configuration source.</li> </ul>
<b>ETS DCBX Oper status</b>	Operational status of the ETS configuration on the local port: match or mismatch.
<b>Reason</b>	Reason displayed when the DCBX operational status for ETS on a port is down.
<b>State Machine Type</b>	Type of state machine used for DCBX exchanges of ETS parameters: Feature — for legacy DCBX versions; Asymmetric — for an IEEE version.
<b>Conf TLV Tx Status</b>	Status of ETS Configuration TLV advertisements: enabled or disabled.
<b>ETS TLV Statistic: Input Conf TLV pkts</b>	Number of ETS Configuration TLVs received.
<b>ETS TLV Statistic: Output Conf TLV pkts</b>	Number of ETS Configuration TLVs transmitted.
<b>ETS TLV Statistic: Error Conf TLV pkts</b>	Number of ETS Error Configuration TLVs received.

### Example (Summary)

```

Dell(conf)# show interfaces te 0/1 ets summary
Interface TenGigabitEthernet 0/1
Max Supported TC Groups is 4
Number of Traffic Classes is 8
Admin mode is on
Admin Parameters:
-----
Admin is enabled
TC-grp Priority#          Bandwidth TSA
0      0,1,2,3,4,5,6,7    100%      ETS
1      0%                  ETS
2      0%                  ETS
3      0%                  ETS
4      0%                  ETS
5      0%                  ETS
6      0%                  ETS
7      0%                  ETS
Priority#          Bandwidth TSA
0      13%           ETS
1      13%           ETS
2      13%           ETS
3      13%           ETS
4      12%           ETS
5      12%           ETS
6      12%           ETS
7      12%           ETS
Remote Parameters:
-----
Remote is disabled
Local Parameters:
-----
Local is enabled
TC-grp Priority#          Bandwidth TSA
0      0,1,2,3,4,5,6,7    100%      ETS
1      0%                  ETS
2      0%                  ETS
3      0%                  ETS
4      0%                  ETS
5      0%                  ETS
6      0%                  ETS
7      0%                  ETS
Priority#          Bandwidth TSA
0      13%           ETS

```

```

1          13%    ETS
2          13%    ETS
3          13%    ETS
4          12%    ETS
5          12%    ETS
6          12%    ETS
7          12%    ETS
Oper status is init
Conf TLV Tx Status is disabled
Traffic Class TLV Tx Status is disabled

```

### Example (Detail)

```

Dell(conf)# show interfaces tengigabitethernet 0/1 ets detail
Interface TenGigabitEthernet 0/1
Max Supported TC Groups is 4
Number of Traffic Classes is 8
Admin mode is on
Admin Parameters :
-----
Admin is enabled
TC-grp Priority#      Bandwidth TSA
0      0,1,2,3,4,5,6,7  100%    ETS
1          0%    ETS
2          0%    ETS
3          0%    ETS
4          0%    ETS
5          0%    ETS
6          0%    ETS
7          0%    ETS

Priority#            Bandwidth TSA
0          13%    ETS
1          13%    ETS
2          13%    ETS
3          13%    ETS
4          12%    ETS
5          12%    ETS
6          12%    ETS
7          12%    ETS

Remote Parameters:
-----
Remote is disabled

Local Parameters :
-----
Local is enabled
TC-grp Priority#      Bandwidth TSA
0      0,1,2,3,4,5,6,7  100%    ETS
1          0%    ETS
2          0%    ETS
3          0%    ETS
4          0%    ETS
5          0%    ETS
6          0%    ETS
7          0%    ETS

Priority#            Bandwidth TSA
0          13%    ETS
1          13%    ETS
2          13%    ETS
3          13%    ETS
4          12%    ETS
5          12%    ETS
6          12%    ETS
7          12%    ETS

Oper status is init
ETS DCBX Oper status is Down
Reason: Port Shutdown
State Machine Type is Asymmetric
Conf TLV Tx Status is enabled
Reco TLV Tx Status is enabled

```

```
0 Input Conf TLV Pkts, 0 Output Conf TLV Pkts, 0 Error Conf TLV Pkts
0 Input Traffic Class TLV Pkts, 0 Output Traffic Class TLV Pkts, 0 Error
Traffic Class
TLV Pkts
```

## show interface pfc

Displays the PFC configuration applied to ingress traffic on an interface, including priorities and link delay.

**Syntax** `show interface port-type slot/port pfc {summary | detail}`

**Parameters**

<b><i>port-type slot/ port pfc</i></b>	Enter the port-type slot and port PFC information.
<b>{summary   detail}</b>	Enter the keyword <code>summary</code> for a summary list of results or enter the keyword <code>detail</code> for a full list of results.

**NOTE:** This command also enables you to view information corresponding to a range of ports.

- You can specify multiple ports as `slot/port-range`. For example, if you want to display information corresponding to all ports between 1 and 4, specify the port range as `show interfaces interface-type 1/1 - 4`.

**Command Modes** INTERFACE

**Supported Modes** All Modes

<b>Command History</b>	<b>Version</b>	<b>Description</b>
	<b>9.9(0.0)</b>	Introduced on the FN IOM and added support to display the interface configurations corresponding to a range of ports.
	<b>9.4(0.0)</b>	Supported on the FN I/O Aggregator.
	<b>9.2(0.0)</b>	Introduced on the M I/O Aggregator.
	<b>8.3.16.1</b>	Introduced on the MXL 10/40GbE Switch IO Module.

**Usage Information** To clear the PFC TLV counters, use the `clear pfc counters interface port-type slot/port` command.

The following describes the `show interface pfc summary` command shown in the following example.

<b>Field</b>	<b>Description</b>
<b>Interface</b>	Interface type with stack-unit and port number.
<b>Admin mode is on Admin is enabled</b>	PFC admin mode is on or off with a list of the configured PFC priorities. When the PFC admin mode is on, PFC advertisements are enabled to be sent and received from peers; received PFC configuration take effect. The admin operational status for a DCBX exchange of PFC configuration is enabled or disabled.
<b>Remote is enabled, Priority list Remote Willing Status is enabled</b>	Operational status (enabled or disabled) of peer device for DCBX exchange of PFC configuration with a list of the configured PFC priorities. Willing status of peer device for DCBX exchange (Willing bit received in PFC TLV): enabled or disabled.
<b>Local is enabled</b>	DCBX operational status (enabled or disabled) with a list of the configured PFC priorities.
<b>Operational status (local port)</b>	Port state for current operational PFC configuration: <ul style="list-style-type: none"> <li><code>Init</code>: Local PFC configuration parameters were exchanged with the peer.</li> <li><code>Recommend</code>: Remote PFC configuration parameters were received from the peer.</li> </ul>



Field	Description
	<ul style="list-style-type: none"> <li>Internally propagated: PFC configuration parameters were received from the configuration source.</li> </ul>
<b>PFC DCBX Oper status</b>	Operational status for the exchange of the PFC configuration on the local port: match (up) or mismatch (down).
<b>Reason</b>	Reason displayed when the DCBx operational status for PFC on a port is down.
<b>State Machine Type</b>	Type of state machine used for DCBX exchanges of the PFC parameters: Feature — for legacy DCBX versions; Symmetric — for an IEEE version.
<b>TLV Tx Status</b>	Status of the PFC TLV advertisements: enabled or disabled.
<b>PFC Link Delay</b>	Link delay (in quanta) used to pause specified priority traffic.
<b>Application Priority TLV: FCOE TLV Tx Status</b>	Status of FCoE advertisements in application priority TLVs from the local DCBX port: enabled or disabled.
<b>Application Priority TLV: SCSI TLV Tx Status</b>	Status of iSCSI advertisements in application priority TLVs from the local DCBX port: enabled or disabled.
<b>Application Priority TLV: Local FCOE Priority Map</b>	Priority bitmap the local DCBX port uses in FCoE advertisements in application priority TLVs.
<b>Application Priority TLV: Local iSCSI Priority Map</b>	Priority bitmap the local DCBX port uses in iSCSI advertisements in application priority TLVs.
<b>Application Priority TLV: Remote FCOE Priority Map</b>	Status of FCoE advertisements in application priority TLVs from the remote peer port: enabled or disabled.
<b>Application Priority TLV: Remote iSCSI Priority Map</b>	Status of iSCSI advertisements in application priority TLVs from the remote peer port: enabled or disabled.
<b>PFC TLV Statistics: Input TLV pkts</b>	Number of PFC TLVs received.
<b>PFC TLV Statistics: Output TLV pkts</b>	Number of PFC TLVs transmitted.
<b>PFC TLV Statistics: Error pkts</b>	Number of PFC error packets received.
<b>PFC TLV Statistics: Pause Tx pkts</b>	Number of PFC pause frames transmitted.
<b>PFC TLV Statistics: Pause Rx pkts</b>	Number of PFC pause frames received.

**Example (Summary)**

```
Dell# show interfaces tengigabitethernet 0/4 pfc summary
Interface TenGigabitEthernet 0/4
Admin mode is on
```

```

Admin is enabled
Remote is enabled, Priority list is 4
Remote Willing Status is enabled
Local is enabled
Oper status is Recommended
PFC DCBX Oper status is Up
State Machine Type is Feature
TLV Tx Status is enabled
PFC Link Delay 45556 pause quantams
Application Priority TLV Parameters :
-----
FCOE TLV Tx Status is disabled
ISCSI TLV Tx Status is disabled
Local FCOE PriorityMap is 0x8
Local ISCSI PriorityMap is 0x10
Remote FCOE PriorityMap is 0x8
Remote ISCSI PriorityMap is 0x8

Dell# show interfaces tengigabitethernet 0/4 pfc detail
Interface TenGigabitEthernet 0/4
Admin mode is on
Admin is enabled
Remote is enabled
Remote Willing Status is enabled
Local is enabled
Oper status is recommended
PFC DCBX Oper status is Up
State Machine Type is Feature
TLV Tx Status is enabled
PFC Link Delay 45556 pause quanta
Application Priority TLV Parameters :
-----
FCOE TLV Tx Status is disabled
ISCSI TLV Tx Status is disabled
Local FCOE PriorityMap is 0x8
Local ISCSI PriorityMap is 0x10
Remote FCOE PriorityMap is 0x8
Remote ISCSI PriorityMap is 0x8
0 Input TLV pkts, 1 Output TLV pkts, 0 Error pkts,
0 Pause Tx pkts, 0 Pause Rx pkts

```

## show interface pfc statistics

Displays counters for the PFC frames received and transmitted (by dot1p priority class) on an interface.

**Syntax** `show interface port-type slot/port pfc statistics`

**Parameters**

- port-type*** Enter the port type.
- slot/port*** Enter the slot/port number.

**i** **NOTE:** This command also enables you to view information corresponding to a range of ports.

- You can specify multiple ports as `slot/port-range`. For example, if you want to display information corresponding to all ports between 1 and 4, specify the port range as `show interfaces interface-type 1/1 - 4`.

**Command Modes** INTERFACE

**Supported Modes** All Modes

**Command History**

Version	Description
9.9(0.0)	Introduced on the FN IOM and added support to display the interface configurations corresponding to a range of ports.

Version	Description
9.4(0.0)	Supported on the FN I/O aggregator. This command is supported in Programmable-Mux (PMUX) mode only.
9.2(0.0)	Introduced on the M I/O Aggregator.
8.3.16.1	Introduced on the MXL 10/40GbE Switch IO Module.

### Example (Summary)

```
Dell#show interfaces te 0/3 pfc statistics
Interface TenGigabitEthernet 0/3

Priority Rx XOFF Frames Rx Total Frames Tx Total Frames
-----
0          0          0          0
1          0          0          0
2          0          0          0
3          0          0          0
4          0          0          0
5          0          0          0
6          0          0          0
7          0          0          0
```

## show qos dcb-map

Display the DCB parameters configured in a specified DCB map.

**Syntax** `show qos dcb-map map-name`

**Parameters** *map-name* Displays the PFC and ETS parameters configured in the specified map.

**Command Modes**

- EXEC
- EXEC Privilege

**Supported Modes** All Modes

Command History	Version	Description
	9.9(0.0)	Introduced on the FN IOM.
	9.6(0.0)	Supported on the FN I/O Aggregator.
	9.2(0.0)	Introduced on the M I/O Aggregator.

**Usage Information** Use the `show qos dcb-map` command to display the enhanced transmission selection (ETS) and priority-based flow control (PFC) parameters used to configure server-facing Ethernet ports.

The following table describes the `show qos dcb-map` output shown in the example below.

Field	Description
<b>State</b>	Complete: All mandatory DCB parameters are correctly configured. In progress: The DCB map configuration is not complete. Some mandatory parameters are not configured.
<b>PFC Mode</b>	PFC configuration in DCB map: On (enabled) or Off.
<b>PG</b>	Priority group configured in the DCB map.
<b>TSA</b>	Transmission scheduling algorithm used by the priority group: Enhanced Transmission Selection (ETS).
<b>BW</b>	Percentage of bandwidth allocated to the priority group.
<b>PFC</b>	PFC setting for the priority group: On (enabled) or Off.

Field	Description
Priorities	802.1p priorities configured in the priority group.

### Example

```
Dell# show qos dcb-map dcbmap2

State      :Complete
PfcMode:ON
-----
PG:0 TSA:ETS  BW:50  PFC:OFF
Priorities:0 1 2 4 5 6 7

PG:1 TSA:ETS  BW:50  PFC:ON
Priorities:3
```

## show stack-unit stack-ports ets details

Displays the ETS configuration applied to egress traffic on stacked ports, including ETS Operational mode on each unit and the configured priority groups with dot1p priorities, bandwidth allocation, and scheduler type.

**Syntax** `show stack-unit {all | stack-unit} stack-ports {all | port-number} ets details`

**Parameters**

- stack-unit*** Enter the stack unit identification.
- port-number*** Enter the port number.

**Command Modes** CONFIGURATION

**Supported Modes** All Modes

### Command History

Version	Description
9.9(0.0)	Introduced on the FN IOM.
9.4(0.0)	Supported on the FN I/O Aggregator.
9.2(0.0)	Introduced on the M I/O Aggregator.
8.3.16.1	Introduced on the MXL 10/40GbE Switch IO Module.

### Example

```
Dell(conf)# show stack-unit all stack-ports all ets details

Stack unit 0 stack port all
Max Supported TC Groups is 4
Number of Traffic Classes is 1
Admin mode is on

Admin Parameters:
-----
Admin is enabled
TC-grp Priority#          Bandwidth TSA
-----
0          0,1,2,3,4,5,6,7  100%      ETS
1          - -
2          - -
3          - -
4          - -
5          - -
6          - -
7          - -
8          - -

Stack unit 1 stack port all
```

```

Max Supported TC Groups is 4
Number of Traffic Classes is 1
Admin mode is on
Admin Parameters:
-----
Admin is enabled
TC-grp Priority#           Bandwidth TSA
-----
0          0,1,2,3,4,5,6,7  100%      ETS
1          -                -         -
2          -                -         -
3          -                -         -
4          -                -         -
5          -                -         -
6          -                -         -
7          -                -         -
8          -                -         -

```

## show stack-unit stack-ports pfc details

Displays the PFC configuration applied to ingress traffic on stacked ports, including PFC Operational mode on each unit with the configured priorities, link delay, and number of pause packets sent and received.

**Syntax** `show stack-unit {all | stack-unit} stack-ports {all | port-number} pfc details`

**Parameters**

- stack-unit*** Enter the stack unit.
- port-number*** Enter the port number.

**Command Modes** CONFIGURATION

**Supported Modes** All Modes

Command History	Version	Description
	<b>9.9(0.0)</b>	Introduced on the FN IOM.
	<b>9.4(0.0)</b>	Supported on the FN I/O Aggregator.
	<b>9.2(0.0)</b>	Introduced on the M I/O Aggregator.
	<b>8.3.16.1</b>	Introduced on the MXL 10/40GbE Switch IO Module.

### Example

```

Dell(conf)# show stack-unit all stack-ports all pfc details

stack unit 0 stack-port all
  Admin mode is On
  Admin is enabled, Priority list is 4-5
  Local is enabled, Priority list is 4-5
  Link Delay 45556 pause quantum
  0 Pause Tx pkts, 0 Pause Rx pkts

stack unit 1 stack-port all
  Admin mode is On
  Admin is enabled, Priority list is 4-5
  Local is enabled, Priority list is 4-5
  Link Delay 45556 pause quantum
  0 Pause Tx pkts, 0 Pause Rx pkts

```

# Dynamic Host Configuration Protocol

Dynamic host configuration protocol (DHCP) is an application layer protocol that dynamically assigns IP addresses and other configuration parameters to network end-stations (hosts) based on configuration policies determined by network administrators.

An Aggregator can operate as a DHCP client. As a DHCP client, the Aggregator requests an IP address from a DHCP server.

The following types of DHCP commands are described in this chapter:

- DHCP Client Commands
- Other Commands supported by DHCP Client

## DHCP Client Commands

- [clear ip dhcp client statistics](#)
- [ip address dhcp](#)
- [release dhcp interface](#)
- [renew dhcp interface](#)
- [show ip dhcp client statistics](#)
- [show ip dhcp lease](#)

## Other Commands supported by DHCP Client

- [debug ip dhcp client events](#)
- [debug ip dhcp client packets](#)

## Topics:

- [clear ip dhcp client statistics](#)
- [debug ip dhcp client events](#)
- [debug ip dhcp client packets](#)
- [ip address dhcp](#)
- [release dhcp interface](#)
- [renew dhcp interface](#)
- [show ip dhcp client statistics](#)
- [show ip dhcp lease](#)

## clear ip dhcp client statistics

Displays DHCP client statistics, including the number of DHCP messages sent and received on an interface.

**Syntax** `clear ip dhcp client statistics interface type slot/port`

**Parameters**

<b>interface type</b>	<b>slot/port</b>	Clear DHCP client statistics on the specified interface.

- For the management interface on the stack-unit, enter the keyword `managementethernet` followed by slot/port information. The slot and port range is 0.
- For a VLAN, enter the keyword `vlan` followed by a number from 1 to 4094.

**Command Modes** EXEC Privilege

**Supported Modes** All Modes

**Default** None

Command History	Version	Description
	<b>9.9(0.0)</b>	Introduced on the FN IOM.
	<b>9.4(0.0)</b>	Supported on the FN I/O Aggregator.

Version	Description
8.3.17.0	Supported on the M I/O Aggregator.

## debug ip dhcp client events

Enable the display of log messages for the following events on DHCP client interfaces:

- IP address acquisition
- IP address release
- Renewal of IP address and lease time
- Release of an IP address

**Syntax** `debug ip dhcp client events [interface type slot/port]`

**Parameters**

<b>interface type slot/port</b>	Description
	Display log messages for DHCP packets sent and received on the specified interface.
	<ul style="list-style-type: none"> <li>• For the management interface on the stack-unit, enter the keyword <code>managementethernet</code> followed by slot/port information. The slot and port range is 0</li> <li>• For a VLAN, enter the keyword <code>vlan</code> followed by a number from 1 to 4094.</li> </ul>

**Command Modes** EXEC Privilege

**Supported Modes** All Modes

**Default** None

Command History	Version	Description
	9.9(0.0)	Introduced on the FN IOM.
	9.4(0.0)	Supported on the FN I/O Aggregator.
	8.3.17.0	Supported on the M I/O Aggregator.

## debug ip dhcp client packets

Enable the display of log messages for all DHCP packets sent and received on DHCP client interfaces.

**Syntax** `debug ip dhcp client packets [interface type slot/port]`

**Parameters**

<b>interface type slot/port</b>	Description
	Display log messages for DHCP packets sent and received on the specified interface.
	<ul style="list-style-type: none"> <li>• For the management interface on the stack-unit, enter the keyword <code>managementethernet</code> followed by slot/port information. The slot and port range is 0</li> <li>• For a VLAN, enter the keyword <code>vlan</code> followed by a number from 1 to 4094.</li> </ul>

**Command Modes** EXEC Privilege

**Supported Modes** All Modes

**Default** None

Command History	Version	Description
	9.9(0.0)	Introduced on the FN IOM.
	9.4(0.0)	Supported on the FN I/O Aggregator.

Version	Description
8.3.17.0	Supported on the M I/O Aggregator.

## ip address dhcp

Acquire an IP address dynamically on an interface from the DHCP server.

**Syntax** `ip address dhcp [relay | vendor-class-identifier]`  
 To disable DHCP Client on an interface, use the `no ip address dhcp` command.

**Command Modes** INTERFACE

**Supported Modes** All Modes

**Default** Enabled

**Command History**

Version	Description
---------	-------------

9.9(0.0)	Introduced on the FN IOM.
9.4(0.0)	Supported on the FN I/O Aggregator.
8.3.17.0	Supported on the M I/O Aggregator.

**Usage Information** In the I/O Aggregator, the DHCP client is enabled only on the default VLAN and management interface 0/0. Use the `ip address` command to assign a static IP address that overwrites the dynamically assigned IP address.

## release dhcp interface

Release the dynamically-acquired IP address on an Ethernet interface while retaining the DHCP client configuration on the interface.

**Syntax** `release dhcp interface type slot/port`

**Parameters**

interface type slot/port	
	<ul style="list-style-type: none"> <li>For the management interface on the stack-unit, enter the keyword <code>management ethernet</code> followed by slot/port information. The slot and port range is 0.</li> <li>For a VLAN, enter the keyword <code>vlan</code> followed by a number from 1 to 4094.</li> </ul>

**Command Modes** EXEC Privilege

**Supported Modes** All Modes

**Default** None

**Command History**

Version	Description
---------	-------------

9.9(0.0)	Introduced on the FN IOM.
9.4(0.0)	Supported on the FN I/O Aggregator.
9.2(0.0)	Supported on the M I/O Aggregator.

**Usage Information** When you enter the `release dhcp` command, although the IP address that was dynamically-acquired from a DHCP server is released from an interface, the ability to acquire a new DHCP server-assigned address remains in the running configuration for the interface. To acquire a new IP address, enter either the `renew dhcp` command at the EXEC privilege level or the `ip address dhcp` command at the interface configuration level.



# renew dhcp interface

Re-acquire a dynamic IP address on an Ethernet interface enabled as a DHCP client.

**Syntax** `renew dhcp interface type slot/port`

**Parameters**

<b>interface type slot/port</b>	Enter any of the following keywords and slot/port or number to clear counters from a specified interface: <ul style="list-style-type: none"><li>For the management interface on the stack-unit, enter the keyword <code>managementethernet</code> followed by slot/port information. The slot and port range is 0.</li><li>For a VLAN, enter the keyword <code>vlan</code> followed by a number from 1 to 4094.</li></ul>
---------------------------------	---

**Command Modes** EXEC Privilege

**Supported Modes** All Modes

**Default** None.

Command History	Version	Description
	<b>9.9(0.0)</b>	Introduced on the FN IOM.
	<b>9.4(0.0)</b>	Supported on the FN I/O Aggregator.
	<b>8.3.17.0</b>	Supported on the M I/O Aggregator.

**Usage information**

The `renew dhcp` command is used to renew the lease of IP address obtained through dhcp.

To display the currently configure dynamic IP address and lease time, enter the `show ip dhcp lease` command.

# show ip dhcp client statistics

Displays DHCP client statistics, including the number of DHCP messages sent and received on an interface.

**Syntax** `show ip dhcp client statistics interface type slot/port`

**Parameters**

<b>interface type slot/port</b>	Display DHCP client statistics on the specified interface. <ul style="list-style-type: none"><li>For the management interface on the stack-unit, enter the keyword <code>managementethernet</code> followed by slot/port information. The slot and port range is 0.</li><li>For a VLAN, enter the keyword <code>vlan</code> followed by a number from 1 to 4094.</li></ul>
---------------------------------	--

**Command Modes** EXEC Privilege

**Supported Modes** All Modes

**Default** None.

Command History	Version	Description
	<b>9.9(0.0)</b>	Introduced on the FN IOM.
	<b>9.4(0.0)</b>	Supported on the FN I/O Aggregator.
	<b>8.3.17.0</b>	Supported on the M I/O Aggregator.

# show ip dhcp lease

Displays lease information about the dynamic IP address currently assigned to a DHCP client-enabled interface.

**Syntax** `show ip dhcp lease[interface type slot/port]`

**Parameters**

<b>interface type</b> <i>slot/port</i>	Display DHCP client statistics on the specified interface. <ul style="list-style-type: none"><li>• For the management interface on the stack-unit, enter the keyword <code>managementethernet</code> followed by slot/port information. The slot and port range is 0.</li><li>• For a VLAN, enter the keyword <code>vlan</code> followed by a number from 1 to 4094.</li></ul>
---	--

**Command Modes** EXEC Privilege

**Supported Modes** All Modes

**Default** Display DHCP lease information on all DHCP client-enabled interfaces on the switch.

<b>Command History</b>	<b>Version</b>	<b>Description</b>
	<b>9.9(0.0)</b>	Introduced on the FN IOM.
	<b>9.4(0.0)</b>	Supported on the FN I/O Aggregator.
	<b>8.3.17.0</b>	Supported on the M I/O Aggregator.

# FC Flex IO Modules

This chapter provides a generic, broad-level description of the operations, capabilities, and configuration commands of the Fiber Channel (FC) Flex IO module.

## Topics:

- [Fibre Channel over Ethernet for FC Flex IO Modules](#)
- [NPIV Proxy Gateway for FC Flex IO Modules](#)
- [description \(for FCoE maps\)](#)
- [fabric](#)
- [fabric-id vlan](#)
- [fcf-priority](#)
- [fc-map](#)
- [fcoe-map](#)
- [fka-adv-period](#)
- [interface vlan \(NPIV proxy gateway\)](#)
- [keepalive](#)
- [show fc switch](#)
- [show fcoe-map](#)
- [show npiv devices](#)
- [show running-config fcoe-map](#)

## Fibre Channel over Ethernet for FC Flex IO Modules

FCoE provides a converged Ethernet network that allows the combination of storage-area network (SAN) and LAN traffic on a Layer 2 link by encapsulating Fibre Channel data into Ethernet frames.

The Aggregator, installed with the FC Flex IO module, functions as a top-of-rack edge switch that supports converged enhanced Ethernet (CEE) traffic — Fibre channel over Ethernet (FCoE) for storage, Interprocess Communication (IPC) for servers, and Ethernet local area network (LAN) (IP cloud) for data — as well as FC links to one or more storage area network (SAN) fabrics.

FCoE works with the Ethernet enhancements provided in Data Center Bridging (DCB) to support lossless (no-drop) SAN and LAN traffic. In addition, DCB provides flexible bandwidth sharing for different traffic types, such as LAN and SAN, according to 802.1p priority classes of service. DCBx should be enabled on the system before the FIP snooping feature is enabled.

All of the commands that are supported for FCoE on the I/O Aggregator apply to the FC Flex IO modules. Similarly, all of the configuration procedures and the settings that are applicable for FCoE on the I/O Aggregator are valid for the FC Flex IO modules.

## NPIV Proxy Gateway for FC Flex IO Modules

The N-port identifier virtualization (NPIV) Proxy Gateway (NPG) feature provides FCoE-FC bridging capability on the M I/O Aggregator with the FC Flex IO module switch, allowing server CNAs to communicate with SAN fabrics over the M I/O Aggregator with the FC Flex IO module.

To configure the M I/O Aggregator with the FC Flex IO module to operate as an NPIV proxy gateway, use the following commands:

## description (for FCoE maps)

In an FCoE map, add a text description of the FCoE and FC parameters used to transmit storage traffic over an M I/O Aggregator with the FC Flex IO module NPIV proxy gateway in a converged fabric.

### M I/O Aggregator with the FC Flex IO module

**Syntax** `description text`

**Parameters** `text` Enter a maximum of 32 characters.

**Defaults** None

**Command Modes** FCOE MAP

**Supported Modes** Programmable-Mux (PMUX)

Command History	Version	Description
	9.3(0.0)	Introduced on the M I/O Aggregator and MXL 10/40GbE Switch with the FC Flex IO module.

**Usage Information** The text description is displayed in `show fcoe-map` command output.

**Related Commands** [fcoe-map](#) — creates an FCoE map which contains the parameters used in the communication between servers and a SAN fabric.

[show fcoe-map](#) — displays the Fibre Channel and FCoE configuration parameters in FCoE maps.

## fabric

Apply an FCoE map on a fabric-facing Fibre Channel (FC) port.

### M I/O Aggregator with the FC Flex IO module

**Syntax** `fabric map-name`

**Parameters** `map-name` Maximum: 32 alphanumeric characters.

**Defaults** None

**Command Modes** INTERFACE FIBRE\_CHANNEL

**Supported Modes** Programmable-Mux (PMUX)

Command History	Version	Description
	9.3(0.0)	Introduced on the M I/O Aggregator and MXL 10/40GbE Switch with the FC Flex IO module.

**Usage Information** An FCoE map is a template used to map FCoE and FC parameters in a converged fabric. An FCoE map is used to virtualize upstream FC ports on an M I/O Aggregator with the FC Flex IO module NPIV proxy gateway so that they appear to downstream server CNA ports as FCoE forwarder (FCF) ports on an FCoE network. When applied to FC and Ethernet ports on an NPIV proxy gateway, an FCoE map allows the switch to operate as an FCoE-FC bridge between an FC SAN and an FCoE network by providing FCoE-enabled servers and switches with the necessary parameters to log in to a SAN fabric. Use the `fcoe-map` command to create an FCoE map.

On an M I/O Aggregator with the FC Flex IO module NPIV proxy gateway, you cannot apply an FCoE map on fabric-facing FC ports and server-facing Ethernet ports.

After you apply an FCoE map on an FC interface, when the port is enabled (`no shutdown`), the NPIV proxy gateway starts sending FIP multicast advertisements on behalf of the FC port to downstream servers in order to advertise the availability of a new FCF port on the FCoE VLAN.

To remove an FCoE map from an FC interface, enter the `no fabric map-name` command in Interface configuration mode.

#### Related Commands

[fcoe-map](#) — creates an FCoE map which contains the parameters used in the communication between servers and a SAN fabric.

[show fcoe-map](#)— displays the Fibre Channel and FCoE configuration parameters in FCoE maps.

## fabric-id vlan

In an FCoE map, configure the association between the dedicated VLAN used to carry FCoE traffic between servers and a SAN, and the fabric where the desired storage arrays are installed.

## M I/O Aggregator with the FC Flex IO module

**Syntax** `fabric-id fabric-num vlan vlan-id`

#### Parameters

**fabric-id fabric-num** Enter a fabric ID number that is the same as the ID number of the dedicated VLAN used to carry FCoE storage traffic to the fabric specified in the FCoE map. You can enter a fabric ID in the range 1–4094.

**vlan vlan-id** Enter the ID number of the dedicated VLAN used to carry FCoE storage traffic between servers and a SAN fabric and specified with the `vlan` command in the FCoE map.

**Defaults** None

**Command Modes** FCOE MAP

**Supported Modes** Programmable-Mux (PMUX)

#### Command History

Version	Description
9.3(0.0)	Introduced on the M I/O Aggregator and MXL 10/40GbE Switch with the FC Flex IO module.

#### Usage Information

In the `fabric-id vlan` command, the fabric and VLAN ID numbers must be the same.

In each FCoE map, the fabric ID, FC-MAP value, and FCoE VLAN parameters must be unique.

To remove a fabric-VLAN association from an FCoE map, enter the `no fabric-id vlan` command.

You must first create a VLAN and then specify the configured VLAN ID in the `fabric-id vlan` command. Otherwise, the following error message is displayed.

```
FTOS(conf-fcoe-f)#fabric-id 10 vlan 10 % Error: Vlan 10 does not exist
```

#### Related Commands

[fcoe-map](#) — creates an FCoE map which contains the parameters used in the communication between servers and a SAN fabric.

[show fcoe-map](#)— displays the Fibre Channel and FCoE configuration parameters in FCoE maps.

# fcf-priority

In an FCoE map, configure the priority used by a server CNA to select an upstream FCoE forwarder (FCF).

## M I/O Aggregator with the FC Flex IO module

<b>Syntax</b>	<code>fcf-priority priority</code>	
<b>Parameters</b>	<b>priority</b>	Enter the priority assigned to the M I/O Aggregator with the FC Flex IO module NPIV proxy gateway, which appears to a downstream server CNA as an FCF. The range of FCF priority values is from 1 to 255.
<b>Defaults</b>	128	
<b>Command Modes</b>	FCOE MAP	
<b>Supported Modes</b>	Programmable-Mux (PMUX)	
<b>Command History</b>	<b>Version</b>	<b>Description</b>
	<b>9.3(0.0)</b>	Introduced on the M I/O Aggregator and MXL 10/40GbE Switch with the FC Flex IO module.
<b>Usage Information</b>	The FCF priority you assign to an M I/O Aggregator with the FC Flex IO module is used by server CNAs to select an upstream FCF to use for a fabric login (FLOGI). To remove a configured FCF priority from an FCoE map, enter the <code>no fcf-priority</code> command.	
<b>Related Commands</b>	<a href="#">fcoe-map</a> — creates an FCoE map which contains the parameters used in the communication between servers and a SAN fabric. <a href="#">show fcoe-map</a> — displays the Fibre Channel and FCoE configuration parameters in FCoE maps.	

# fc-map

In an FCoE map, configure the FCoE mapped address prefix (FC-MAP) value which is used to identify FCoE traffic transmitted on the FCoE VLAN for the specified fabric.

## M I/O Aggregator with the FC Flex IO module

<b>Syntax</b>	<code>fc-map fc-map-value</code>	
<b>Parameters</b>	<b>fc-map-value</b>	Enter the unique MAC address prefix used by a SAN fabric. The range of FC-MAP values is from 0EFC00 to 0EFCFF.
<b>Defaults</b>	None	
<b>Command Modes</b>	FCOE MAP	
<b>Supported Modes</b>	Programmable-Mux (PMUX)	
<b>Command History</b>	<b>Version</b>	<b>Description</b>
	<b>9.3(0.0)</b>	Introduced on the M I/O Aggregator and MXL 10/40GbE Switch with the FC Flex IO module.
<b>Usage Information</b>	The FC-MAP value you enter must match the FC-MAP value used by an FC switch or FCoE forwarder (FCF) in the fabric. An FCF switch accepts only FCoE traffic that uses the correct FC-MAP value.	

The FC-MAP value is used to generate the fabric-provided MAC address (FP-MAC). The FPMA is used by servers to transmit FCoE traffic to the fabric. An FC-MAP can be associated with only one FCoE VLAN and vice versa.

In an FCoE map, the FC-MAP value, fabric ID, and FCoE VLAN parameters must be unique.

To remove a configured FC-MAP value from an FCoE map, enter the `no fcoe-map` command.

#### Related Commands

`fcoe-map` — creates an FCoE map which contains the parameters used in the communication between servers and a SAN fabric.

## fcoe-map

Create an FCoE map which contains the parameters used to configure the links between server CNAs and a SAN fabric. Apply the FCoE map on a server-facing Ethernet port.

## M I/O Aggregator with the FC Flex IO module

**Syntax** `fcoe-map map-name`

**Parameters** **map-name** Maximum: 32 alphanumeric characters.

**Defaults** On the I/O Aggregator with PMUX modules, the following parameters are applied on all the PMUX module interfaces:

- Description: SAN\_FABRIC
- Fabric-id: 1002
- Fcoe-vlan: 1002
- Fc-map: 0x0efc00
- Fcf-priority: 128
- Fka-adv-period: 8000mSec
- Keepalive: enable
- Vlan priority: 3

**Command Modes** CONFIGURATION  
INTERFACE

**Supported Modes** Programmable-Mux (PMUX)

Command History	Version	Description
	<b>9.3(0.0)</b>	Introduced on the M I/O Aggregator and MXL 10/40GbE Switch with the FC Flex IO module.

#### Usage Information

An FCoE map is a template used to map FCoE and FC parameters in a converged fabric. An FCoE map is used to virtualize upstream FC ports on an M I/O Aggregator with the PMUX module NPIV proxy gateway so that they appear to downstream server CNA ports as FCoE forwarder (FCF) ports on an FCoE network. When applied to FC and Ethernet ports on an NPIV proxy gateway, an FCoE map allows the switch to operate as an FCoE-FC bridge between an FC SAN and an FCoE network by providing FCoE-enabled servers and switches with the necessary parameters to log in to a SAN fabric.

On an M I/O Aggregator with the PMUX module NPIV proxy gateway, you cannot apply an FCoE map is applied on fabric-facing FC ports and server-facing 10-Gigabit Ethernet ports.

An FCoE map consists of the following parameters: the dedicated FCoE VLAN used for storage traffic, the destination SAN fabric (FC-MAP value), FCF priority used by a server, and the FIP keepalive (FKA) advertisement timeout.

In each FCoE map, the fabric ID, FC-MAP value, and FCoE VLAN parameters must be unique. Use one FCoE map to access one SAN fabric. You cannot use the same FCoE map to access different fabrics.

To remove an FCoE map from an Ethernet interface, enter the `no fcoe-map map-name` command in Interface configuration mode.

**Related Commands**

`show fcoe-map`— displays the Fibre Channel and FCoE configuration parameters in FCoE maps.

## fka-adv-period

In an FCoE map, configure the time interval used to transmit FIP keepalive (FKA) advertisements.

### M I/O Aggregator with the FC Flex IO module

**Syntax** `fka-adv-period seconds`

**Parameters** **seconds** Enter the time period (in seconds) used to send FIP keepalive messages to peer devices. The range is from 8 to 90 seconds.

**Defaults** 8 seconds

**Command Modes** FCOE MAP

**Supported Modes** Programmable-Mux (PMUX)

Command History	Version	Description
	9.3(0.0)	Introduced on the M I/O Aggregator and MXL 10/40GbE Switch with the FC Flex IO module.

**Usage Information** To delete the FIP keepalive time period from an FCoE map, enter the `no fka-adv-erpiod` command.

**Related Commands** `fcoe-map` — creates an FCoE map which contains the parameters used in the communication between servers and a SAN fabric.

## interface vlan (NPIV proxy gateway)

Create a dedicated VLAN to be used to send and receive Fibre Channel traffic over FCoE links between servers and a fabric over an M I/O Aggregator with the PMUX module NPIV proxy gateway.

### M I/O Aggregator with the FC Flex IO module

**Syntax** `interface vlan vlan-id`

**Parameters** **vlan-id** Enter a number as the VLAN Identifier. The range is 1 to 4094.

**Defaults** Not configured.

**Command Modes** CONFIGURATION

**Supported Modes** Programmable-Mux (PMUX)

Command History	Version	Description
	9.3(0.0)	Introduced on the M I/O Aggregator and MXL 10/40GbE Switch with the FC Flex IO module configured as an NPIV proxy gateway.



### Usage Information

FCoE storage traffic received from servers on an M I/O Aggregator with the PMUX module NPIV proxy gateway is de-capsulated into Fibre Channel packets and forwarded over FC links to SAN switches in a specified fabric. You must configure a separate FCoE VLAN for each fabric to which FCoE traffic is forwarded. Any non-FCoE traffic sent on a dedicated FCoE VLAN will be dropped.

You configure the association between a dedicated VLAN, which carries FCoE traffic from server CNAs over the NPIV proxy gateway to a SAN fabric in which destination storage arrays are installed, in an FCoE map by using the `fabric id vlan` command.

When you apply an FCoE map to a server-facing Ethernet port, the port is automatically configured as a tagged member of the FCoE VLAN.

For more information about VLANs and the commands to configure them, refer to the [Virtual LAN \(VLAN\) Commands](#) section.

### Example (Single Range)

```
Dell(conf)#interface vlan 10
Dell(conf-if-vl-3)#
```

### Related Commands

`fcoe-map` — creates an FCoE map which contains the parameters used in the communication between servers and a SAN fabric.

## keepalive

In an FCoE map, enable the monitoring of FIP keepalive messages (if it is disabled).

## M I/O Aggregator with the FC Flex IO module

**Syntax** `keepalive`

**Parameters** None

**Defaults** FIP keepalive monitoring is enabled on Ethernet and Fibre Channel interfaces.

**Command Modes** FCOE MAP

**Supported Modes** Programmable-Mux (PMUX)

### Command History

#### Version

#### Description

**9.3(0.0)**

Introduced on the M I/O Aggregator and MXL 10/40GbE Switch with the FC Flex IO module.

### Usage Information

FIP keepalive (FKA) messaging is used to detect if other FCoE devices are reachable.

To remove FIP keepalive monitoring from an FCoE map, enter the `no keepalive` command.

### Related Commands

`fcoe-map` — creates an FCoE map which contains the parameters used in the communication between servers and a SAN fabric.

## show fc switch

Display the switch configuration for Fibre Channel capability.

## M I/O Aggregator with the FC Flex IO module

**Syntax** `show fc switch`

**Parameters** None

- Command Modes**
- EXEC
  - EXEC Privilege

**Supported Modes** All Modes

Command History	Version	Description
	<b>9.7(0.0)</b>	Introduced on the M I/O Aggregator.

**Usage Information** The following table describes the `show fc switch` output shown in the following example.

<b>Switch Mode</b>	Fibre Channel mode of operation of an Aggregator.
<b>Switch WWN</b>	Factory-assigned worldwide node (WWN) name of the Aggregator. The M I/O Aggregator WWN name is not user-configurable.

**Example**

```
Dell(conf)#do show fc switch
Switch Mode : NPG
Switch WWN  : 10:00:aa:00:00:00:00:ac
Dell(conf)#
```

## show fcoe-map

Display the Fibre Channel and FCoE configuration parameters in FCoE maps.

### M I/O Aggregator with the FC Flex IO module

**Syntax** `show fcoe-map [brief | map-name]`

<b>Parameters</b>	<b>brief</b>	Displays an overview of currently configured FCoE maps.
	<b>map-name</b>	Displays the FC and FCoE configuration parameters in a specified FCoE map. The FCoE map is applied on Ethernet (FCoE) and FC ports to transmit FC storage traffic to a specified fabric.

- Command Modes**
- EXEC
  - EXEC Privilege

**Supported Modes** All Modes

Command History	Version	Description
	<b>9.3(0.0)</b>	Introduced on the M I/O Aggregator and MXL 10/40GbE Switch with the FC Flex IO module.

**Usage Information** Use the `show fcoe-map` command to display the FC and FCoE parameters used to configure server-facing Ethernet (FCoE) and fabric-facing FC ports in all FCoE maps on an M I/O Aggregator with the FC Flex IO module NPIV proxy gateway.

In each FCoE map, the values for the fabric ID and FC-MAP that identify the SAN fabric to which FC storage traffic is sent, and the FCoE VLAN to be used must be unique.

An FCoE map is used to identify the SAN fabric to which FCoE storage traffic is sent and to virtualize M I/O Aggregator with the FC Flex IO module FC ports so that they appear to downstream server CNA ports as FCoE Forwarder (FCF) ports on an FCoE network.

The following table describes the `show fcoe-map brief` output shown in the example below.

Field	Description
<b>Fabric-Name</b>	Name of a SAN fabric.

Field	Description
<b>Fabric ID</b>	The ID number of the SAN fabric to which FC traffic is forwarded.
<b>VLAN ID</b>	The dedicated FCoE VLAN used to transport FCoE storage traffic between servers and a fabric over the NPIV proxy gateway. The configured VLAN ID must be the same as the fabric ID.
<b>FC-MAP</b>	FCoE MAC address-prefix value - The unique 24-bit MAC address prefix that identifies a fabric.
<b>FCF Priority</b>	The priority used by a server to select an upstream FCoE forwarder.
<b>Config-State</b>	Indicates whether the configured FCoE and FC parameters in the FCoE map are valid: Active (all mandatory FCoE and FC parameters are correctly configured) or Incomplete (either the FC-MAP value, fabric ID, or VLAN ID are not correctly configured).
<b>Oper-State</b>	Operational status of link to the fabric: Up (link is up and transmitting FC traffic), Down (link is down and not transmitting FC traffic), Link-wait (link is up and waiting for FLOGI to complete on peer FC port), or Removed (port has been shut down).

The following table describes the `show fcoe-map map-name` output shown in the example below.

Field	Description
<b>Fabric-Name</b>	Name of a SAN fabric.
<b>Fabric ID</b>	The ID number of the SAN fabric to which FC traffic is forwarded.
<b>VLAN ID</b>	The dedicated FCoE VLAN used to transport FCoE storage traffic between servers and a fabric over the NPIV proxy gateway. The configured VLAN ID must be the same as the fabric ID.
<b>VLAN priority</b>	FCoE traffic uses VLAN priority 3. (This setting is not user-configurable.)
<b>FC-MAP</b>	FCoE MAC address-prefix value - The unique 24-bit MAC address prefix that identifies a fabric.
<b>FKA-ADV-period</b>	Time interval (in seconds) used to transmit FIP keepalive advertisements.
<b>FCF Priority</b>	The priority used by a server to select an upstream FCoE forwarder.
<b>Config-State</b>	Indicates whether the configured FCoE and FC parameters in the FCoE map are valid: Active (all mandatory FCoE and FC parameters are correctly configured) or Incomplete (either the FC-MAP value, fabric ID, or VLAN ID are not correctly configured).
<b>Oper-State</b>	Operational status of link to the fabric: Up (link is up and transmitting FC traffic), Down (link is down and not transmitting FC traffic), Link-wait (link is up and waiting for FLOGI to complete on peer FC port), or Removed (port has been shut down).
<b>Members</b>	M I/O Aggregator with the FC Flex IO module Ethernet and FC ports that are members of the dedicated FCoE VLAN that carries storage traffic to the specified fabric.

### Example

```
Dell#show fcoe-map brief
Fabric-Name Fabric-Id Vlan-Id FC-MAP FCF-Priority Config-State Oper-
State
test 16 16 0efc02 128 ACTIVE UP
cnatest 1003 1003 0efc03 128 ACTIVE UP
sitest 1004 1004 0efc04 128 ACTIVE DOWN
```

```
Dell#show fcoe-map si
Fabric Name si
Fabric Id 1004
```

```

Vlan Id          1004
Vlan priority    3
FC-MAP           0efc04
FKA-ADV-Period  8
Fcf Priority     128
Config-State    ACTIVE
Oper-State      DOWN
Members

```

**Related Commands**

[fcoe-map](#) — creates an FCoE map which contains the parameters used in the communication between servers and a SAN fabric.

## show npiv devices

Display the FCoE and FC devices currently logged into an M I/O Aggregator with the FC Flex IO module NPIV proxy gateway.

### M I/O Aggregator with the FC Flex IO module

**Syntax** `show npiv devices [brief]`

**Parameters** **brief** Displays an overview of current server CNA-fabric connections over an M I/O Aggregator with the FC Flex IO module NPIV proxy gateway.

**Command Modes**

- EXEC
- EXEC Privilege

**Supported Modes** All Modes

Command History	Version	Description
	<b>9.3(0.0)</b>	Introduced on the M I/O Aggregator and MXL 10/40GbE Switch with the FC Flex IO module.

**Usage Information** Use the `show npiv devices` command to display information on the server CNA, server-facing Ethernet and fabric-facing FC ports, and the SAN fabric in each server-fabric connection over an M I/O Aggregator with the FC Flex IO module that operates as an NPIV proxy gateway.

The following table describes the `show npiv devices brief` output shown in the example below.

Field	Description
<b>ENode-Intf</b>	M I/O Aggregator with the FC Flex IO module Ethernet interface ( <i>slot/port</i> ) to which a server CNA is connected.
<b>ENode-WWPN</b>	Worldwide port name (WWPN) of a server CNA port.
<b>FCoE-Vlan</b>	VLAN ID of the dedicated VLAN used to transmit FCoE traffic to and from the fabric.
<b>Fabric-Intf</b>	Fabric-facing Fibre Channel port ( <i>slot/port</i> ) on which FC traffic is transmitted to the specified fabric.
<b>Fabric-Map</b>	Name of the FCoE map containing the FCoE/FC configuration parameters for the server CNA-fabric connection.
<b>LoginMethod</b>	Method used by the server CNA to log in to the fabric; for example: FLOGI - ENode logged in using a fabric login (FLOGI). FDISC - ENode logged in using a fabric discovery (FDISC).
<b>Status</b>	Operational status of the link between a server CNA port and a SAN fabric: Logged In - Server has logged in to the fabric and is able to transmit FCoE traffic.

## Example

```
Dell# show npiv devices brief
Total NPIV Devices = 2
-----
ENode-Intf  ENode-WWPN          FCoE-Vlan  Fabric-Intf  Fabric-Map  LoginMethod  Status
-----
Te 0/12     20:01:00:10:18:f1:94:20  1003      Fc 0/5      fid_1003    FLOGI        LOGGED_IN
Te 0/13     10:00:00:00:c9:d9:9c:cb  1003      Fc 0/0      fid_1003    FDISC        LOGGED_IN
```

## Usage Information

The following table describes the `show npiv devices` output shown in the example below.

Field	Description
<b>ENode [number]</b>	A server CNA that has successfully logged in to a fabric over an M I/O Aggregator with the FC Flex IO module Ethernet port in ENode mode.
<b>ENode MAC</b>	MAC address of a server CNA port.
<b>ENode Intf</b>	Port number of a server-facing Ethernet port operating in ENode mode.
<b>FCF MAC</b>	Fibre Channel forwarder MAC: MAC address of M I/O Aggregator with the FC Flex IO module FCF interface.
<b>Fabric Intf</b>	Fabric-facing Fibre Channel port ( <i>slot/port</i> ) on which FCoE traffic is transmitted to the specified fabric.
<b>FCoE VLAN</b>	ID of the dedicated VLAN used to transmit FCoE traffic from a server CNA to a fabric and configured on both the server-facing M I/O Aggregator with the FC Flex IO module port and server CNA port.
<b>Fabric Map</b>	Name of the FCoE map containing the FCoE/FC configuration parameters for the server CNA-fabric connection.
<b>ENode WWPN</b>	Worldwide port name of the server CNA port.
<b>ENode WWNN</b>	Worldwide node name of the server CNA.
<b>FCoE MAC</b>	Fabric-provided MAC address (FPMA). The FPMA consists of the FC-MAP value in the FCoE map and the FC-ID provided by the fabric after a successful FLOGI. In the FPMA, the most significant bytes are the FC-MAP; the least significant bytes are the FC-ID.
<b>FC-ID</b>	FC port ID provided by the fabric.
<b>LoginMethod</b>	Method used by the server CNA to log in to the fabric; for example, FLOGI or FDISC.
<b>Secs</b>	Number of seconds that the fabric connection is up.
<b>State</b>	Status of the fabric connection: logged in.

## Example

```
ENode[0]:
ENode MAC      : 00:10:18:f1:94:21
ENode Intf     : Te 0/12
FCF MAC        : 5c:f9:dd:ef:10:c8
Fabric Intf    : Fc 0/5
FCoE Vlan      : 1003
Fabric Map     : fid_1003
ENode WWPN     : 20:01:00:10:18:f1:94:20
ENode WWNN     : 20:00:00:10:18:f1:94:21
FCoE MAC       : 0e:fc:03:01:02:01
FC-ID          : 01:02:01
LoginMethod    : FLOGI
Secs           : 5593
Status         : LOGGED_IN

ENode[1]:
ENode MAC      : 00:10:18:f1:94:22
ENode Intf     : Te 0/13
FCF MAC        : 5c:f9:dd:ef:10:c9
Fabric Intf    : Fc 0/0
FCoE Vlan      : 1003
```

```
Fabric Map      :      fid_1003
ENode WWPN     :      10:00:00:00:c9:d9:9c:cb
ENode WWNN     :      10:00:00:00:c9:d9:9c:cd
FCoE MAC       :      0e:fc:03:01:02:02
FC-ID          :      01:02:01
LoginMethod    :      FDISC
Secs           :      5593
Status         :      LOGGED_IN
```

**Related  
Commands**

[fcoe-map](#) — creates an FCoE map which contains the parameters used in the communication between servers and a SAN fabric.

## show running-config fcoe-map

Displays the current fcoe-map configurations.

## M I/O Aggregator with the FC Flex IO module

**Syntax** `show running-config fcoe-map`

**Command Modes** EXEC Privilege

**Supported Modes** All Modes

**Command  
History**

**Version**

**Description**

**9.6(0.0)**

Supported on the FN2210S Aggregator.

**9.3(0.0)**

Introduced on the M I/O Aggregator and MXL 10/40GbE Switch with the FC Flex IO module.

**Example**

```
Dell(conf)#do show running-config fcoe-map
!
fcoe-map map
fc-map 0efc00
fabric-id 100 vlan 100
```

## FC FLEXIO FPORT

The switch is a blade switch which is plugged into the Dell M1000 Blade server chassis. The blade module contains two slots for pluggable flexible module. With single FC Flex IO module, 4 ports are supported, whereas 8 ports are supported with both FC Flex IO modules. Each port can operate in 2G, 4G or 8G Fiber Channel speed. The topology-wise, FC Flex IOM is directly connected to a FC Storage. In the following topology, the FC flex IOM model offers local connectivity without a SAN switch or fabric.

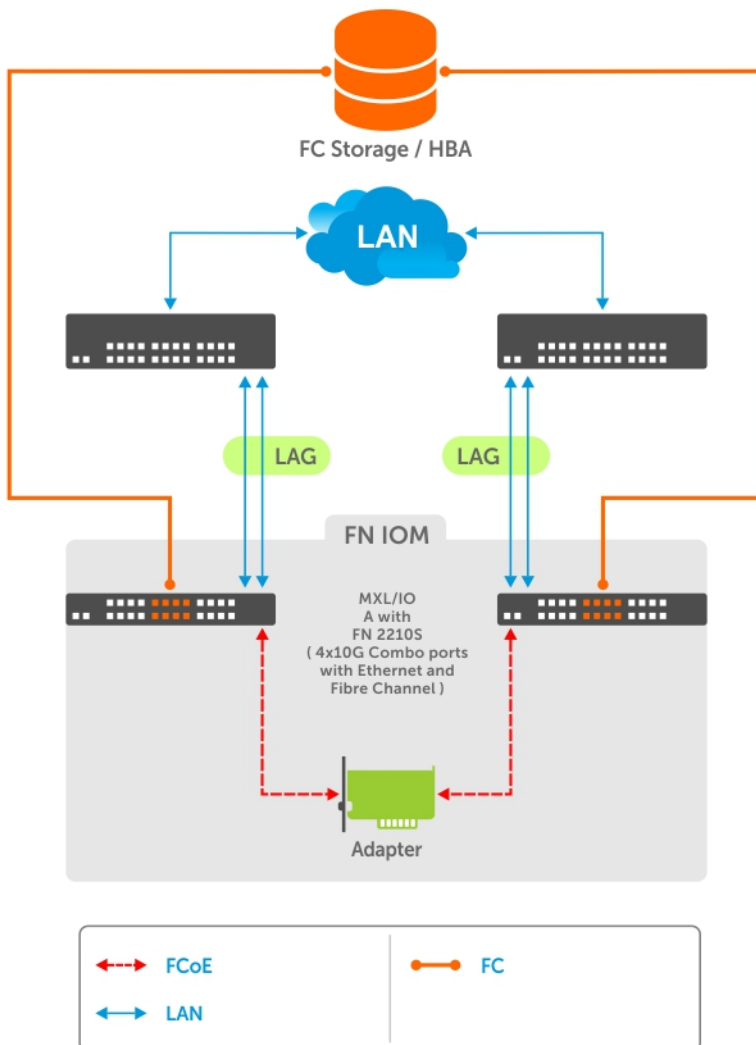

### Topics:

- `active-zoneset`
- `fabric`
- `fc alias`
- `fc zone`
- `fc zoneset`
- `fcoe-map`
- `feature fc`
- `show fc alias`
- `show fc ns`

- [show fc switch](#)
- [show fc zone](#)
- [show fc zoneset](#)
- [show fcoe-map](#)

## active-zoneset

Activate the zoneset.

**Syntax** `active-zoneset zoneset_name`

To change to the default zone behavior, use the `no active-zoneset zoneset_name` command.

**Parameters** `zoneset_name` Enter the zoneset name.

**Command Modes** FC FABRIC CONFIGURATION

**Supported Modes** All Modes

Command History	Version	Description
	<b>9.9(0.0)</b>	Supported on the FN I/O Aggregator.
	<b>9.7(0.0)</b>	Introduced on the M I/O Aggregator.

### Example

```
Dell(conf)# fcoe-map default_full_fabric
Dell(conf-fcoe-default_full_fabric)# fc-fabric
Dell(conf-fmap-default_full_fabric-fcfabric)# active-zoneset zsl
```

**Related Commands** [show fc zoneset](#) — displays the configured and active zoneset.

## fabric

Apply an FCoE map on a fabric-facing Fibre Channel (FC) port.

**Syntax** `fabric map-name`

**Parameters** `map-name` Maximum: 32 alphanumeric characters.

**Defaults** None

**Command Modes** INTERFACE FIBRE\_CHANNEL

**Supported Modes** All Modes

Command History	Version	Description
	<b>9.9(0.0)</b>	Supported on the FN I/O Aggregator.
	<b>9.7(0.0)</b>	Introduced on the M I/O Aggregator.

### Usage Information

An FCoE map is a template used to map FCoE and FC parameters in a converged fabric. An FCoE map virtualizes the upstream FC ports on the switch NPIV proxy gateway to appear to downstream server CNA ports as FCoE forwarder (FCF) ports on an FCoE network. When applied to FC and Ethernet ports on an NPIV proxy gateway, an FCoE map allows the switch to operate as an FCoE-FC bridge between an FC SAN and an FCoE network. It provides necessary parameters to FCoE-enabled servers and switches to log in to a SAN fabric. Use the `fcoe-map` command to create an FCoE map.

On the switch NPIV proxy gateway, an FCoE map is applied on fabric-facing FC ports and server-facing Ethernet ports. Use the `fabric` command to apply an FCoE map on an FC port. Use the `fcoe-map` command to apply an FCoE map on an Ethernet port.



After you apply an FCoE map on an FC interface, when the port is enabled (`no shutdown`), the NPIV proxy gateway starts sending FIP multicast advertisements on behalf of the FC port to downstream servers to advertise the availability of a new FCF port on the FCoE VLAN.

To remove an FCoE map from an FC interface, enter the `no fabric map-name` command in Interface configuration mode.

#### Related Commands

[fcoe-map](#) — creates an FCoE map which contains the parameters used in the communication between servers and a SAN fabric.

[show fcoe-map](#)— displays the Fibre Channel and FCoE configuration parameters in FCoE maps.

## fc alias

Create a zone alias name.

**Syntax** `fc alias ZoneAliasName member name`

To delete a zone alias name, use the `no fc zone ZoneAliasName` command.

#### Parameters

**ZoneAliasName** Enter the zone alias name.  
**member name** Enter the WWPN, port ID, or domain/port.

**Command Modes** CONFIGURATION

**Supported Modes** All Modes

#### Command History

Version	Description
9.9(0.0)	Supported on the FN I/O Aggregator.
9.7(0.0)	Introduced on the M I/O Aggregator.

#### Example

```
Syntax:
Dell(conf)#fc alias test12
Dell(conf-fc-alias-test12)#?
end                               Exit from configuration mode
exit                               Exit from Alias config mode
member                             Add Alias member
no                                 Negate a command or set its defaults
show                               Show alias profile configuration
Dell(conf-fc-alias-test12)#member ?
WORD                               WWN(00:00:00:00:00:00:00:00), or portID(123000)
```

#### Related Commands

[show fc alias](#) — displays the configured alias.

## fc zone

Create a zone.

**Syntax** `fc zone zonename member`

To delete a zone, use the `no fc zone zonename member` command.

#### Parameters

**zonename** Enter the zone name.  
**member** Enter the WWPN, port ID, or domain/port.

**Command Modes** ALIAS CONFIGURATION

**Supported Modes** All Modes

Command History	Version	Description
	9.7(0.0)	Introduced on the M I/O Aggregator.

#### Example without member

```
Dell(conf)# fc zone z1
Dell(conf-fc-zone-z1)#
```

#### Example with member

```
Dell(conf)#fc zone test
Dell(conf-fc-zone-test)#member ?
WORD                               WWN(00:00:00:00:00:00:00:00), portID(000000), or
Alias name(word)
Dell(conf-fc-zone-test)#member
```

**Related Commands**

[show fc zone](#) — displays the configured zone.

[show fcoe-map](#) — displays the fabric parameters.

## fc zoneset

Create a zoneset.

**Syntax** `fc zoneset zoneset_name [member]`

To delete a zoneset, use the `no fc zoneset zoneset_name [member]` command.

**Parameters**

**zoneset\_name** Enter the zoneset name.

**member** Enter the WWPN, FC-ID, or Alias name.

**Command Modes** CONFIGURATION

**Supported Modes** All Modes

Command History	Version	Description
	9.9(0.0)	Supported on the FN I/O Aggregator.
	9.7(0.0)	Introduced on the M I/O Aggregator.

#### Example

```
Dell(conf)#fc zoneset test1
Dell(conf-fc-zoneset-test1)#member ?
WORD                               Zone Name
Dell(conf-fc-zoneset-test1)#member
```

**Related Commands**

[show fc zoneset](#) — displays the configured and active zoneset.

[show fcoe-map](#) — displays the fabric parameters.

## fcoe-map

Create an FCoE map which contains the parameters used to configure the links between server CNAs and a SAN fabric. Apply the FCoE map on a server-facing Ethernet port.

**Syntax** `fcoe-map map-name`

**Parameters**

**map-name** Maximum: 32 alphanumeric characters.

**Defaults** None

**Command Modes** CONFIGURATION

INTERFACE

**Supported Modes** All Modes

**Command History**

Version	Description
9.9(0.0)	Supported on the FN I/O Aggregator.
9.3(0.0)	Introduced on the M I/O Aggregator.

**Usage Information**

An FCoE map is a template to map FCoE and FC parameters in a converged fabric. An FCoE map virtualizes upstream FC ports on the switch NPIV proxy gateway to appear to downstream server CNA ports as FCoE forwarder (FCF) ports on an FCoE network. When applied to FC and Ethernet ports on an NPIV proxy gateway, an FCoE map allows the switch to operate as an FCoE-FC bridge between an FC SAN and an FCoE network. It provides necessary parameters to FCoE-enabled servers and switches to log in to a SAN fabric.

On the switch NPIV proxy gateway, an FCoE map is applied on fabric-facing FC ports and server-facing Ethernet ports. Use the `fcoe-map` command to apply an FCoE map on an Ethernet port. Use the `fabric` command to apply an FCoE map on an FC port.

An FCoE map consists of the following parameters: the dedicated FCoE VLAN for storage traffic, the destination SAN fabric (FC-MAP value), FCF priority, and the FIP keepalive (FKA) advertisement timeout.

To remove an FCoE map from an Ethernet interface, enter the `no fcoe-map map-name` command in Interface configuration mode.

 **NOTE:** You cannot create `fcoe-map` in IOA mode. It can only be created in PMUX mode.

 **NOTE:** In FCF F mode, you can create only one FCoE map. It doesn't get created automatically. If you try to create more than one map, an error message is displayed.

**Related Commands**

`show fcoe-map` — displays the Fibre Channel and FCoE configuration parameters in FCoE maps.

## feature fc

Enable feature `fc` with FPort functionality.

**Syntax** `feature fc fport domain-id range`

**Parameters** **Range** Enter the range from 1 to 239.

**Command Modes** CONFIGURATION

**Supported Modes** All Modes

**Command History**

Version	Description
9.9(0.0)	Supported on the FN I/O Aggregator.
9.7(0.0)	Introduced on the M I/O Aggregator.

**Usage Information**

Enable `remote-fault-signaling rx off` command in FCF FPort mode on interfaces connected to the Compellent and MDF storage devices.

**Example**

```
Dell(conf)#feature fc fport domain-id
```

# show fc alias

Display the configured alias.

- Syntax** `show fc alias [ZoneAliasName ]`
- Parameters** **ZoneAliasName** Enter the zone alias name to display the details.
- Command Modes**
- EXEC
  - EXEC Privilege
- Supported Modes** All Modes

Command History	Version	Description
	<b>9.9(0.0)</b>	Supported on the FN I/O Aggregator.
	<b>9.7(0.0)</b>	Introduced on the M I/O Aggregator.

### Example

```
Dell#show fc alias
Zone Alias Name      all
0x030303
Dell#
```

**Related Commands** [fc alias](#) — creates a zone alias name.

# show fc ns

Display the devices in the name server database.

- Syntax** `show fc ns { switch } [brief]`
- Parameters**
- switch** Enter the keyword `switch` to display all the devices in the name server database of the switch.
  - brief** Enter the keyword `brief` to display in brief devices in the name server database.
- Command Modes**
- EXEC
  - EXEC Privilege
- Supported Modes** All Modes

Command History	Version	Description
	<b>9.9(0.0)</b>	Supported on the FN I/O Aggregator.
	<b>9.7(0.0)</b>	Introduced on the M I/O Aggregator.

### Example

```
Dell#show fc ns switch
Total number of devices =      1
Switch Name                   10:00:5c:f9:dd:ef:0a:00
Domain Id                     1
Switch Port                   53
Port Id                       01:35:00
Port Name                     10:00:8c:7c:ff:17:f8:01
Node Name                     20:00:8c:7c:ff:17:f8:01
Class of Service              8
IP Address
Symbolic Port Name           Brocade-1860 | 3.0.3.0 | DV-SP-SERVER2 |
|
```

```

Symbolic Node Name          (NULL)
Port Type                   Node port
Registered with NameServer  Yes
Registered for SCN         Yes
Display of local name server entries - brief version
Dell#

Dell#show fc ns switch brief
Total number of devices = 1
Intf#   Domain   FC-ID           Enode-WWPN
Enode-WWNN
53      1         01:35:00       10:00:8c:7c:ff:17:f8:01
20:00:8c:7c:ff:17:f8:01
Dell#

Dell#show fc ns fabric
Total number of devices = 3
Switch Name                10:00:5c:f9:dd:ef:0a:80
Domain Id                  2
Switch Port                9
Port Id                    02:09:00
Port Name                  32:11:0e:fc:00:00:00:88
Node Name                  22:11:0e:fc:00:00:00:88
Class of Service          8
IP Address
Symbolic Port Name        (NULL)
Symbolic Node Name        (NULL)
Port Type                 Node port
Registered with NameServer No
Registered for SCN        No
Switch Name                10:00:5c:f9:dd:ef:0a:80
Domain Id                  2
Switch Port                11
Port Id                    02:0b:00
Port Name                  31:11:0e:fc:00:00:00:77
Node Name                  21:11:0e:fc:00:00:00:77
Class of Service          8
IP Address
Symbolic Port Name        (NULL)
Symbolic Node Name        (NULL)
Port Type                 Node port
Registered with NameServer No
Registered for SCN        No
Switch Name                10:00:5c:f9:dd:ef:0a:00
Domain Id                  1
Switch Port                53
Port Id                    01:35:00
Port Name                  10:00:8c:7c:ff:17:f8:01
Node Name                  20:00:8c:7c:ff:17:f8:01
Class of Service          8
IP Address
Symbolic Port Name        Brocade-1860 | 3.0.3.0 | DV-SP-SERVER2 |
|
Symbolic Node Name        (NULL)
Port Type                 Node port
Registered with NameServer Yes
Registered for SCN        Yes
Dell#

Dell#show fc ns fabric brief
Total number of devices = 2
Intf#   Domain   FC-ID           Enode-WWPN
Enode-WWNN
9       2         02:09:00       32:11:0e:fc:00:00:00:88
22:11:0e:fc:00:00:00:88
11      2         02:0b:00       31:11:0e:fc:00:00:00:77
21:11:0e:fc:00:00:00:77
Dell#

```

# show fc switch

Display the switch configuration for Fibre Channel capability.

**Syntax** `show fc switch`

**Parameters** None

**Command Modes**

- EXEC
- EXEC Privilege

**Supported Modes** All Modes

Command History	Version	Description
	<b>9.9(0.0)</b>	Supported on the FN I/O Aggregator.
	<b>9.7(0.0)</b>	Introduced on the M I/O Aggregator.

**Usage Information** The following table describes the `show fc switch` output shown in the following example.

<b>Switch Mode</b>	Fibre Channel mode of operation of an MXL switch.
<b>Switch WWN</b>	Factory-assigned worldwide node (WWN) name of the MXL. The MXL WWN name is not user-configurable.

## Example

```
Dell(conf)#do show fc switch
Switch Mode : FPORT
Switch WWN  : 10:00:aa:00:00:00:00:ac
Dell(conf)#
```

# show fc zone

Display the configured zone.

**Syntax** `show fc zone [zonename ]`

**Parameters** **zonename** Enter the zone name to display the details.

**Command Modes**

- EXEC
- EXEC Privilege

**Supported Modes** All Modes

Command History	Version	Description
	<b>9.9(0.0)</b>	Supported on the FN I/O Aggregator.
	<b>9.7(0.0)</b>	Introduced on the M I/O Aggregator.

## Example

```
Dell#show fc zone

ZoneName                               ZoneMember
=====
brcd_sanb                               brcd_cna1_wwpn1
                                          sanb_p2tgt1_wwpn

Dell#
```

**Related Commands** [fc zone](#) — creates a zone.

# show fc zoneset

Display the configured and active zoneset.

**Syntax** `show fc zoneset [ zoneset_name | active ]`

**Parameters**

- zoneset\_name** Enter the zoneset name to display the zoneset name
- active** Enter the keyword `active` to display the active zonesets.
- merged** Enter the keyword `merged` to display the merge active zones.

**Command Modes**

- EXEC
- EXEC Privilege

**Supported Modes** All Modes

Command History	Version	Description
	9.9(0.0)	Supported on the FN I/O Aggregator.
	9.7(0.0)	Introduced on the M I/O Aggregator.

## Example

```
Dell#show fc zoneset

ZoneSetName                ZoneName                ZoneMember
=====
fcoe_srv_fc_tgt
                        brcd_sanb
                                brcd_cna1_wwpn1
                                sanb_p2tgt1_wwpn

Active Zoneset: fcoe_srv_fc_tgt

ZoneName                    ZoneMember
=====
brcd_sanb
                                10:00:8c:7c:ff:21:5f:8d
                                20:02:00:11:0d:03:00:00
Dell#

Dell#show fc zoneset active

Active Zoneset: fcoe_srv_fc_tgt

ZoneName                    ZoneMember
=====
brcd_sanb
                                10:00:8c:7c:ff:21:5f:8d
                                20:02:00:11:0d:03:00:00
Dell#
```

**Related Commands**

- [fc zone](#) — creates a zone.
- [fc zoneset](#) — creates a zoneset.
- [active-zoneset](#) — activates the zoneset.

# show fcoe-map

Display the Fibre Channel and FCoE configuration parameters in FCoE maps.

**Syntax** show fcoe-map

**Parameters** None

- Command Modes**
- EXEC
  - EXEC Privilege

**Supported Modes** All Modes

**Command History**

Version	Description
9.9(0.0)	Supported on the FN I/O Aggregator.
9.3(0.0)	Introduced on the M I/O Aggregator.

**Usage Information**

Use the show fcoe-map command to display the FC and FCoE parameters used to configure server-facing Ethernet (FCoE) and fabric-facing FC ports in all FCoE maps on an M I/O Aggregator Switch.

In each FCoE map, the values for the fabric ID and FC-MAP that identify the SAN fabric to which FC storage traffic is sent, and the FCoE VLAN to be used must be unique.

An FCoE map is used to identify the SAN fabric to which FCoE storage traffic is sent. It also virtualizes the switch with the FC Flex IO module FC ports so that they appear to downstream server CNA ports as FCoE Forwarder (FCF) ports on an FCoE network.

**Example**

```
Dell(conf)#do show fcoe-map

Fabric Name          SAN_FABRIC

Fabric Type          npiv
Fabric Id            1002
Vlan Id              1002
Vlan priority        3
FC-MAP               0efc00
FKA-ADV-Period       8
Fcf Priority          128
Config-State         ACTIVE
Oper-State           UP
=====
Members
Fc 0/41 Fc 0/42 Fc 0/43 Fc 0/44 Fc 0/49 Fc 0/50 Fc 0/51 Fc 0/52
Te 0/4 Te 0/9 Te 0/16
=====
Dell(conf)#
```

**Related Commands**

[fcoe-map](#) — creates an FCoE map which contains the parameters used in the communication between servers and a SAN fabric.



# FIP Snooping

In a converged Ethernet network, an Aggregator can operate as an intermediate Ethernet bridge to snoop on Fibre Channel over Ethernet Initialization Protocol (FIP) packets during the login process on Fibre Channel over Ethernet (FCoE) forwarders (FCFs). Acting as a transit FIP snooping bridge, the switch uses dynamically-created ACLs to permit only authorized FCoE traffic to be transmitted between an FCoE end-device and an FCF.

This chapter describes the FIP snooping commands.

## Topics:

- [clear fip-snooping database interface vlan](#)
- [show fip-snooping statistics](#)
- [debug fip-snooping](#)
- [show fip-snooping config](#)
- [show fip-snooping enode](#)
- [show fip-snooping fcf](#)
- [show fip-snooping sessions](#)
- [show fip-snooping statistics](#)
- [show fip-snooping system](#)
- [show fip-snooping vlan](#)

## clear fip-snooping database interface vlan

Clear FIP snooping information on a VLAN for a specified FCoE MAC address, ENode MAC address, or FCF MAC address, and remove the corresponding ACLs FIP snooping generates.

**Syntax** `clear fip-snooping database interface vlan vlan-id {fcoe-mac-address | enode-mac-address | fcf-mac-address}`

**Parameters**

<b><i>fcoe-mac-address</i></b>	Enter the FCoE MAC address to be cleared of FIP snooping information.
<b><i>enode-mac-address</i></b>	Enter the ENode MAC address to be cleared of FIP snooping information.
<b><i>fcf-mac-address</i></b>	Enter the FCF MAC address to be cleared of FIP snooping information.

**Command Modes** EXEC Privilege

**Supported Modes** Programmable-Mux (PMUX)

Command History	Version	Description
	<b>9.9(0.0)</b>	Introduced on the FN IOM.
	<b>9.4(0.0)</b>	Supported on the FN I/O Aggregator.
	<b>9.2(0.0)</b>	Introduced on the M I/O Aggregator.
	<b>8.3.16.1</b>	Introduced on the MXL 10/40GbE Switch IO Module.

## clear fip-snooping statistics

Clear the statistics on the FIP packets snooped on all VLANs, a specified VLAN, or a specified port interface.

**Syntax** `clear fip-snooping statistics [interface vlanVlan-id| interfaceport-type port/slot|interface port-channel port-channel-number]`

**Parameters**

<b>vlan-id</b>	Enter the VLAN ID of the FIP packet statistics to be cleared.
<b>port type port/slot</b>	Enter the port-type and slot number of the FIP packet statistics to be cleared.
<b>port-channel-number</b>	Enter the port channel number of the FIP packet statistics to be cleared.

**Command Modes** EXEC Privilege

**Supported Modes** All Modes

Command History	Version	Description
	<b>9.9(0.0)</b>	Introduced on the FN IOM.
	<b>9.4(0.0)</b>	Supported on the FN I/O Aggregator.
	<b>9.2(0.0)</b>	Introduced on the M I/O Aggregator.
	<b>8.3.16.1</b>	Introduced on the MXL 10/40GbE Switch IO Module.

## feature fip-snooping

Enable FCoE transit and FIP snooping on a switch.

**Syntax** `feature fip-snooping`  
To disable the FCoE transit feature, use the `no feature fip-snooping` command.

**Defaults** Disabled

**Command Modes** CONFIGURATION

**Supported Modes** Programmable-Mux (PMUX)

Command History	Version	Description
	<b>9.9(0.0)</b>	Introduced on the FN IOM.
	<b>9.4(0.0)</b>	Supported on the FN I/O Aggregator.
	<b>9.2(0.0)</b>	Introduced on the M I/O Aggregator.
	<b>8.3.16.1</b>	Introduced on the MXL 10/40GbE Switch IO Module.

## fip-snooping enable

Enable FIP snooping on all VLANs or on a specified VLAN.

**Syntax** `fip-snooping enable`  
To disable the FIP snooping feature on all or a specified VLAN, use the `no fip-snooping enable` command.

**Defaults** FIP snooping is disabled on all VLANs.

**Command Modes**

- CONFIGURATION
- VLAN INTERFACE

**Supported Modes** Programmable-Mux (PMUX)

Command History	Version	Description
	<b>9.9(0.0)</b>	Introduced on the FN IOM.
	<b>9.4(0.0)</b>	Supported on the FN I/O Aggregator.
	<b>9.2(0.0)</b>	Introduced on the M I/O Aggregator.
	<b>8.3.16.1</b>	Introduced on the MXL 10/40GbE Switch IO Module.

**Usage Information** The maximum number of FCFs supported per FIP snooping-enabled VLAN is four. The maximum number of FIP snooping sessions supported per ENode server is 16.

## fip-snooping fc-map

Configure the FC-MAP value FIP snooping uses on all VLANs.

**Syntax** `fip-snooping fc-map fc-map-value`  
To return the configured FM-MAP value to the default value, use the `no fip-snooping fc-map` command.

**Parameters** ***fc-map-value*** Enter the FC-MAP value FIP snooping uses. The range is from 0EFC00 to 0EFCFF.

**Defaults** **0x0EFC00**

**Command Modes**

- CONFIGURATION
- VLAN INTERFACE

**Supported Modes** Programmable-Mux (PMUX)

Command History	Version	Description
	<b>9.9(0.0)</b>	Introduced on the FN IOM.
	<b>9.4(0.0)</b>	Supported on the FN I/O Aggregator.
	<b>9.2(0.0)</b>	Introduced on the M I/O Aggregator.
	<b>8.3.16.1</b>	Introduced on the MXL 10/40GbE Switch IO Module.

## fip-snooping port-mode fcf

Configure the port for bridge-to-FCF links.

**Syntax** `fip-snooping port-mode fcf`  
To disable the bridge-to-FCF link on a port, use the `no fip-snooping port-mode fcf` command.

**Command Modes** INTERFACE

**Supported Modes** Programmable-Mux (PMUX)

Command History	Version	Description
	<b>9.9(0.0)</b>	Introduced on the FN IOM.
	<b>9.4(0.0)</b>	Supported on the FN I/O Aggregator.
	<b>9.2(0.0)</b>	Introduced on the M I/O Aggregator.
	<b>8.3.16.1</b>	Introduced on the MXL 10/40GbE Switch IO Module.

**Usage Information** The maximum number of FCFs supported per FIP snooping-enabled VLAN is four.

# show fip-snooping statistics

Displays statistics on the FIP packets snooped on all interfaces, including VLANs, physical ports, and port channels..

**Syntax** `show fip-snooping statistics [interface vlan vlan-id | interface port-type port/slot | interface port-channel port-channel-number]`

**Parameters**

- vlan-id*** Enter the VLAN ID of the FIP packet statistics to be displayed.
- port-type port/slot*** Enter the port-type and slot number of the FIP packet statistics to be displayed.
- port-channel-number*** Enter the port channel number of the FIP packet statistics to be displayed.

**Command Modes**

- EXEC
- EXEC Privilege

**Supported Modes** All Modes

Command History	Version	Description
	9.9(0.0)	Introduced on the FN IOM.
	9.4(0.0)	Supported on the FN I/O Aggregator.
	8.3.17.0	Supported on the M I/O Aggregator.

**Usage Information** The following table describes the `show fip-snooping statistics` command.

Field	Description
<b>Number of Vlan Requests</b>	Number of FIP-snooped VLAN request frames received on the interface.
<b>Number of VLAN Notifications</b>	Number of FIP-snooped VLAN notification frames received on the interface
<b>Number of Multicast Discovery Solicits</b>	Number of FIP-snooped multicast discovery solicit frames received on the interface.
<b>Number of Unicast Discovery</b>	Number of FIP-snooped unicast discovery solicit frames received on the interface.
<b>Number of FLOGI</b>	Number of FIP-snooped FLOGI request frames received on the interface.
<b>Number of FDISC</b>	Number of FIP-snooped FDISC request frames received on the interface
<b>Number of FLOGO</b>	Number of FIP-snooped FLOGO frames received on the interface
<b>Number of ENode Keep Alives</b>	Number of FIP-snooped ENode keep-alive frames received on the interface
<b>Number of VN Port Keep Alives</b>	Number of FIP-snooped VN port keep-alive frames received on the interface
<b>Number of Multicast Discovery Advertisements</b>	Number of FIP-snooped multicast discovery advertisements received on the interface
<b>Number of Unicast Discovery Advertisements</b>	Number of FIP-snooped unicast discovery advertisements received on the interface

Field	Description
<b>Number of FLOGI Accepts</b>	Number of FIP FLOGI accept frames received on the interface
<b>Number of FLOGI Rejects</b>	Number of FIP FLOGI reject frames received on the interface
<b>Number of FDISC Accepts</b>	Number of FIP FDISC accept frames received on the interface
<b>Number of FDISC Rejects</b>	Number of FIP FDISC reject frames received on the interface
<b>Number of FLOGO Accepts</b>	Number of FIP FLOGO accept frames received on the interface
<b>Number of FLOGO Rejects</b>	Number of FIP FLOGO reject frames received on the interface
<b>Number of CVLs</b>	Number of FIP clear virtual link frames received on the interface
<b>Number of FCF Discovery</b>	Number of FCF discovery timeouts that occurred on the interface
<b>Number of VN Port Session</b>	Number of VN port session timeouts that occurred on the interface
<b>Number of Session failures due to Hardware Config</b>	Number of session failures due to hardware configuration that occurred on the interface

#### Example

```

Dell# show fip-snooping statistics interface vlan 100
Number of Vlan Requests                :0
Number of Vlan Notifications           :0
Number of Multicast Discovery Solicits  :2
Number of Unicast Discovery Solicits    :0
Number of FLOGI                        :2
Number of FDISC                         :16
Number of FLOGO                         :0
Number of Enode Keep Alive              :9021
Number of VN Port Keep Alive            :3349
Number of Multicast Discovery Advertisement :4437
Number of Unicast Discovery Advertisement :2
Number of FLOGI Accepts                  :2
Number of FLOGI Rejects                  :0
Number of FDISC Accepts                  :16
Number of FDISC Rejects                  :0
Number of FLOGO Accepts                  :0
Number of FLOGO Rejects                  :0
Number of CVL                           :0
Number of FCF Discovery Timeouts         :0
Number of VN Port Session Timeouts       :0
Number of Session failures due to Hardware Config :0
Dell(conf)#

Dell# show fip-snooping statistics int tengigabitethernet 0/11
Number of Vlan Requests                :1
Number of Vlan Notifications           :0
Number of Multicast Discovery Solicits  :1
Number of Unicast Discovery Solicits    :0
Number of FLOGI                        :1
Number of FDISC                         :16
Number of FLOGO                         :0
Number of Enode Keep Alive              :4416
Number of VN Port Keep Alive            :3136
Number of Multicast Discovery Advertisement :0
Number of Unicast Discovery Advertisement :0
Number of FLOGI Accepts                  :0

```

```

Number of FLOGI Rejects :0
Number of FDISC Accepts :0
Number of FDISC Rejects :0
Number of FLOGO Accepts :0
Number of FLOGO Rejects :0
Number of CVL :0
Number of FCF Discovery Timeouts :0
Number of VN Port Session Timeouts :0
Number of Session failures due to Hardware Config :0

```

**Example (port channel)**

```

Dell# show fip-snooping statistics interface port-channel 22
Number of Vlan Requests :0
Number of Vlan Notifications :2
Number of Multicast Discovery Solicits :0
Number of Unicast Discovery Solicits :0
Number of FLOGI :0
Number of FDISC :0
Number of FLOGO :0
Number of Enode Keep Alive :0
Number of VN Port Keep Alive :0
Number of Multicast Discovery Advertisement :4451
Number of Unicast Discovery Advertisement :2
Number of FLOGI Accepts :2
Number of FLOGI Rejects :0
Number of FDISC Accepts :16
Number of FDISC Rejects :0
Number of FLOGO Accepts :0
Number of FLOGO Rejects :0
Number of CVL :0
Number of FCF Discovery Timeouts :0
Number of VN Port Session Timeouts :0
Number of Session failures due to Hardware Config :0

```

## debug fip-snooping

Enable the debug FIP protocol specific messages.

**Syntax** `debug fip-snooping [all|acl|error|ifm|info|ipc|rx]`

<b>Parameters</b>		
<b>all</b>	Enable all the debug options.	
<b>acl</b>	Enable for ACL specific debugs	
<b>error</b>	Enable for Error specific debugs	
<b>ifm</b>	Enable for IFM specific debugs	
<b>info</b>	Enable for Information specific debugs	
<b>ipc</b>	Enable for IPC specific debugs	
<b>rx</b>	Enable for packet receive specific debugs	

**Command Modes** EXEC Privilege

**Supported Modes** All Modes

Command History	Version	Description
	8.3.17.0	Supported on the M I/O Aggregator.

# show fip-snooping config

Displays the FIP snooping status and configured FC-MAP values.

**Syntax** `show fip-snooping config`

- Command Modes**
- EXEC
  - EXEC Privilege

**Supported Modes** All Modes

Command History	Version	Description
	<b>9.9(0.0)</b>	Introduced on the FN IOM.
	<b>9.4(0.0)</b>	Supported on the FN I/O Aggregator.
	<b>8.3.17.0</b>	Supported on the M I/O Aggregator.

**Example**

```
Dell#show fip-snooping config
FIP Snooping Feature enabled Status: Enabled
FIP Snooping Global enabled Status: Enabled
Global FC-MAP Value: 0X0EFC00
Dell#
```

# show fip-snooping enode

Displays information on the ENodes in FIP-snooped sessions, including the ENode interface and MAC address, FCF MAC address, VLAN ID, and FC-ID.

**Syntax** `show fip-snooping enode [enode-mac-address]`

**Parameters**

***enode-mac-address*** Enter the MAC address of the ENodes to be displayed.

- Command Modes**
- EXEC
  - EXEC Privilege

**Supported Modes** All Modes

Command History	Version	Description
	<b>9.9(0.0)</b>	Introduced on the FN IOM.
	<b>9.4(0.0)</b>	Supported on the FN I/O Aggregator.
	<b>8.3.17.0</b>	Supported on the M I/O Aggregator.

**Usage Information**

The following table describes the `show fip-snooping enode` command.

Field	Description
<b>ENode MAC</b>	MAC address of the ENode
<b>ENode Interface</b>	Slot/ port number of the interface connected to the ENode.
<b>FCF MAC</b>	MAC address of the FCF
<b>VLAN</b>	VLAN ID number used by the session
<b>FC-ID</b>	Fibre Channel session ID assigned by the FCF.

**Example**

```
Dell# show fip-snooping enode
Enode MAC           Enode Interface       FCF MAC
VLAN                FC-ID
```

```

-----
----- d4:ae:52:1b:e3:cd -----
-----
54:7f:ee:37:34:40 100 62:00:11 Te 0/11

```

## show fip-snooping fcf

Displays information on the FCFs in FIP-snooped sessions, including the FCF interface and MAC address, FCF interface, VLAN ID, FC-MAP value, FKA advertisement period, and number of ENodes connected.

**Syntax** `show fip-snooping fcf[fcf-mac-address]`

**Parameters** *fcf-mac-address* Enter the MAC address of the FCF to be displayed.

**Command Modes**

- EXEC
- EXEC Privilege

**Supported Modes** All Modes

Command History	Version	Description
	9.9(0.0)	Introduced on the FN IOM.
	9.4(0.0)	Supported on the FN I/O Aggregator.
	8.3.17.0	Supported on the M I/O Aggregator.

**Usage Information** The following table describes the `show fip-snooping fcf` command.

Field	Description
<b>FCF MAC</b>	MAC address of the FCF
<b>FCF Interface</b>	Slot/ port number of the interface to which the FCF is connected.
<b>VLAN</b>	VLAN ID number used by the session
<b>FC-MAP</b>	FC-MAP value advertised by the FCF.
<b>FKA_ADV_PERIOD</b>	Period of time (in milliseconds) during which FIP keep-alive advertisements are transmitted.
<b>No of ENodes</b>	Number of ENodes connected to the FCF

### Example

```

Dell# show fip-snooping fcf
FCF MAC          FCF Interface  VLAN  FC-MAP  FKA_ADV_PERIOD
No. of Enodes
-----
-----
54:7f:ee:37:34:40  Po 128        100   0e:fc:00  4000
1

```

## show fip-snooping sessions

Displays information on FIP-snooped sessions on all VLANs or a specified VLAN, including the ENode interface and MAC address, the FCF interface and MAC address, VLAN ID, FCoE MAC address and FCoE session ID number (FC-ID), worldwide node name (WWNN) and the worldwide port name (WWPN).

**Syntax** `show fip-snooping sessions[interface vlan vlan-id]`

**Parameters** *vlan-id* Enter the vlan-id of the specified VLAN to be displayed.

**Command Modes**

- EXEC



- EXEC Privilege

**Supported Modes** All Modes

**Command History**

Version	Description
9.9(0.0)	Introduced on the FN IOM.
9.4(0.0)	Supported on the FN I/O Aggregator.
8.3.17.0	Supported on the M I/O Aggregator.

**Usage Information**

The following table describes the `show fip-snooping sessions` command.

Field	Description
<b>ENode MAC</b>	MAC address of the ENode.
<b>ENode Interface</b>	Slot/ port number of the interface connected to the ENode.
<b>FCF MAC</b>	MAC address of the FCF.
<b>FC Interface</b>	Slot/ port number of the interface to which the FCF is connected.
<b>VLAN</b>	VLAN ID number used by the session.
<b>FCoE MAC</b>	MAC address of the FCoE session assigned by the FCF.
<b>FC-ID</b>	Fibre Channel ID assigned by the FCF.
<b>Port WWPN</b>	Worldwide port name of the CNA port.
<b>Port WWNN</b>	Worldwide node name of the CNA port.

**Example**

```
Dell#show fip-snooping sessions
Enode MAC          Enode Intf      FCF MAC        FCF Intf  VLAN  FCoE MAC
FC-ID
00:0e:1e:0c:54:a6 Te 0/14 00:05:73:f2:4f:ae Po128 100 0e:fc:00:9a:00:27
9a:00:27 20:01:00:0e:1e:0c:54:a6
00:0e:1e:06:01:5e Te 0/16 00:05:73:f2:4f:af Po128 100 0e:fc:00:9a:01:18
9a:01:18 20:01:00:0e:1e:06:01:5
Port WWNN
20:00:00:0e:1e:0c:54:a6
20:00:00:0e:1e:0c:54:a6
```

## show fip-snooping statistics

Displays statistics on the FIP packets snooped on all interfaces, including VLANs, physical ports, and port channels..

**Syntax**

`show fip-snooping statistics [interface vlan vlan-id | interface port-type port/slot | interface port-channel port-channel-number]`

**Parameters**

- vlan-id*** Enter the VLAN ID of the FIP packet statistics to be displayed.
- port-type port/slot*** Enter the port-type and slot number of the FIP packet statistics to be displayed.
- port-channel-number*** Enter the port channel number of the FIP packet statistics to be displayed.

**Command Modes**

- EXEC
- EXEC Privilege

**Supported Modes** All Modes

**Command History**

Version	Description
9.9(0.0)	Introduced on the FN IOM.

Version	Description
9.4(0.0)	Supported on the FN I/O Aggregator.
8.3.17.0	Supported on the M I/O Aggregator.

### Usage Information

The following table describes the `show fip-snooping statistics` command.

Field	Description
<b>Number of Vlan Requests</b>	Number of FIP-snooped VLAN request frames received on the interface.
<b>Number of VLAN Notifications</b>	Number of FIP-snooped VLAN notification frames received on the interface
<b>Number of Multicast Discovery Solicits</b>	Number of FIP-snooped multicast discovery solicit frames received on the interface.
<b>Number of Unicast Discovery</b>	Number of FIP-snooped unicast discovery solicit frames received on the interface.
<b>Number of FLOGI</b>	Number of FIP-snooped FLOGI request frames received on the interface.
<b>Number of FDISC</b>	Number of FIP-snooped FDISC request frames received on the interface
<b>Number of FLOGO</b>	Number of FIP-snooped FLOGO frames received on the interface
<b>Number of ENode Keep Alives</b>	Number of FIP-snooped ENode keep-alive frames received on the interface
<b>Number of VN Port Keep Alives</b>	Number of FIP-snooped VN port keep-alive frames received on the interface
<b>Number of Multicast Discovery Advertisements</b>	Number of FIP-snooped multicast discovery advertisements received on the interface
<b>Number of Unicast Discovery Advertisements</b>	Number of FIP-snooped unicast discovery advertisements received on the interface
<b>Number of FLOGI Accepts</b>	Number of FIP FLOGI accept frames received on the interface
<b>Number of FLOGI Rejects</b>	Number of FIP FLOGI reject frames received on the interface
<b>Number of FDISC Accepts</b>	Number of FIP FDISC accept frames received on the interface
<b>Number of FDISC Rejects</b>	Number of FIP FDISC reject frames received on the interface
<b>Number of FLOGO Accepts</b>	Number of FIP FLOGO accept frames received on the interface
<b>Number of FLOGO Rejects</b>	Number of FIP FLOGO reject frames received on the interface
<b>Number of CVLs</b>	Number of FIP clear virtual link frames received on the interface
<b>Number of FCF Discovery</b>	Number of FCF discovery timeouts that occurred on the interface

Field	Description
<b>Number of VN Port Session</b>	Number of VN port session timeouts that occurred on the interface
<b>Number of Session failures due to Hardware Config</b>	Number of session failures due to hardware configuration that occurred on the interface

### Example

```
Dell# show fip-snooping statistics interface vlan 100
Number of Vlan Requests :0
Number of Vlan Notifications :0
Number of Multicast Discovery Solicits :2
Number of Unicast Discovery Solicits :0
Number of FLOGI :2
Number of FDISC :16
Number of FLOGO :0
Number of Enode Keep Alive :9021
Number of VN Port Keep Alive :3349
Number of Multicast Discovery Advertisement :4437
Number of Unicast Discovery Advertisement :2
Number of FLOGI Accepts :2
Number of FLOGI Rejects :0
Number of FDISC Accepts :16
Number of FDISC Rejects :0
Number of FLOGO Accepts :0
Number of FLOGO Rejects :0
Number of CVL :0
Number of FCF Discovery Timeouts :0
Number of VN Port Session Timeouts :0
Number of Session failures due to Hardware Config :0
Dell(conf)#

Dell# show fip-snooping statistics int tengigabitethernet 0/11
Number of Vlan Requests :1
Number of Vlan Notifications :0
Number of Multicast Discovery Solicits :1
Number of Unicast Discovery Solicits :0
Number of FLOGI :1
Number of FDISC :16
Number of FLOGO :0
Number of Enode Keep Alive :4416
Number of VN Port Keep Alive :3136
Number of Multicast Discovery Advertisement :0
Number of Unicast Discovery Advertisement :0
Number of FLOGI Accepts :0
Number of FLOGI Rejects :0
Number of FDISC Accepts :0
Number of FDISC Rejects :0
Number of FLOGO Accepts :0
Number of FLOGO Rejects :0
Number of CVL :0
Number of FCF Discovery Timeouts :0
Number of VN Port Session Timeouts :0
Number of Session failures due to Hardware Config :0
```

### Example (port channel)

```
Dell# show fip-snooping statistics interface port-channel 22
Number of Vlan Requests :0
Number of Vlan Notifications :2
Number of Multicast Discovery Solicits :0
Number of Unicast Discovery Solicits :0
Number of FLOGI :0
Number of FDISC :0
Number of FLOGO :0
Number of Enode Keep Alive :0
Number of VN Port Keep Alive :0
Number of Multicast Discovery Advertisement :4451
```

```

Number of Unicast Discovery Advertisement      :2
Number of FLOGI Accepts                      :2
Number of FLOGI Rejects                     :0
Number of FDISC Accepts                     :16
Number of FDISC Rejects                     :0
Number of FLOGO Accepts                     :0
Number of FLOGO Rejects                     :0
Number of CVL                               :0
Number of FCF Discovery Timeouts             :0
Number of VN Port Session Timeouts          :0
Number of Session failures due to Hardware Config :0

```

## show fip-snooping system

Displays information on the status of FIP snooping on the switch (enabled or disabled), including the number of FCoE VLANs, FCFs, ENodes, and currently active sessions.

**Syntax** `show fip-snooping system`

- Command Modes**
- EXEC
  - EXEC Privilege

**Supported Modes** All Modes

Command History	Version	Description
	<b>9.9(0.0)</b>	Introduced on the FN IOM.
	<b>9.4(0.0)</b>	Supported on the FN I/O Aggregator.
	<b>8.3.17.0</b>	Supported on the M I/O Aggregator.

**Example**

```

Dell# show fip-snooping system
Global Mode                : Enabled
FCOE VLAN List (Operational) : 1, 100
FCFs                       : 1
Enodes                     : 2
Sessions                   : 17

```

## show fip-snooping vlan

Display information on the FIP snooping operational VLANs.

**Syntax** `show fip-snooping vlan`

- Command Modes**
- EXEC
  - EXEC Privilege

**Supported Modes** All Modes

Command History	Version	Description
	<b>9.9(0.0)</b>	Introduced on the FN IOM.
	<b>9.4(0.0)</b>	Supported on the FN I/O Aggregator.
	<b>8.3.17.0</b>	Introduced on the M I/O Aggregator.

**Example**

```

Dell# show fip-snooping vlan
* = Default VLAN

VLAN      FC-MAP      FCFs      Enodes      Sessions
-----

```

*1	-	-	-	-
1002	0X0EFC00	1	1	1

# Internet Group Management Protocol (IGMP)

The Dell Networking OS supports IGMP snooping version 2 and 3 on all Dell Networking systems.

## Topics:

- IGMP Commands
- IGMP Snooping Commands
- clear ip igmp groups
- debug ip igmp
- ip igmp group-join-limit
- ip igmp querier-timeout
- ip igmp query-interval
- ip igmp query-max-resp-time
- ip igmp snooping enable
- ip igmp snooping fast-leave
- ip igmp snooping flood
- ip igmp snooping last-member-query-interval
- ip igmp snooping mrouter
- ip igmp snooping querier
- ip igmp version
- show ip igmp groups
- show ip igmp interface
- show ip igmp snooping mrouter

## IGMP Commands

The Dell Networking OS supports the following IGMP commands:

- clear ip igmp groups
- debug ip igmp
- ip igmp group-join-limit
- ip igmp querier-timeout
- ip igmp query-interval
- ip igmp query-max-resp-time
- ip igmp snooping enable
- ip igmp snooping fast-leave
- ip igmp snooping flood
- ip igmp snooping last-member-query-interval
- ip igmp snooping mrouter
- ip igmp snooping querier
- ip igmp version
- show ip igmp groups
- show ip igmp interface
- show ip igmp snooping mrouter

## Important Points to Remember

- Dell Networking OS supports version 1, version 2, and version 3 hosts.
- Dell Networking OS IGMP snooping implementation is based on IP multicast address (not based on Layer 2 multicast mac-address) and the IGMP snooping entries are in Layer 3 flow table not in Layer 2 forwarding information base (FIB).
- Dell Networking OS IGMP snooping implementation is based on draft-ietf-magma-snoop-10.
- IGMP snooping is supported on all M I/O Aggregator stack members.
- IGMP snooping is enabled by default on the switch.
- A maximum of 8k groups and 4k virtual local area networks (VLAN) are supported.
- IGMP snooping is not supported on default VLAN interface.
- Flooding of unregistered multicast traffic is enabled by default.
- Queries are not accepted from the server side ports and are only accepted from the uplink LAG.
- Reports and Leaves are flooded by default to the uplink LAG irrespective of whether it is an mrouter port or not.

## IGMP Snooping Commands

Dell Networking OS supports IGMP Snooping version 2 and 3 on all Dell Networking systems.

### Important Points to Remember for IGMP Snooping

- Dell Networking OS supports version 1, version 2, and version 3 hosts.
- Dell Networking OS IGMP snooping implementation is based on IP multicast address (not based on Layer 2 multicast mac address) and the IGMP snooping entries are in Layer 3 flow table not in Layer 2 forwarding information base (FIB).
- Dell Networking OS IGMP snooping implementation is based on draft-ietf-magma-snoop-10.
- Dell Networking OS supports IGMP snooping on JUMBO-enabled cards.
- IGMP snooping is not enabled by default on the switch.
- A maximum of 1800 groups and 600 VLAN are supported.
- IGMP snooping is not supported on a default VLAN interface.
- IGMP snooping is not supported over VLAN-Stack-enabled VLAN interfaces (you must disable IGMP snooping on a VLAN interface before configuring VLAN-Stack-related commands).

## clear ip igmp groups

Clear entries from the group cache table.

**Syntax** `clear ip igmp groups [group-address | interface]`

**Parameters**

<b>group-address</b>	(OPTIONAL) Enter the IP multicast group address in dotted decimal format.
<b>interface</b>	(OPTIONAL) Enter the interface type and slot/port information: For a VLAN interface enter the keyword vlan followed by a number from 1 to 4094.

**Command Modes** EXEC Privilege

**Supported Modes** All Modes

<b>Command History</b>	<b>Version</b>	<b>Description</b>
	<b>9.9(0.0)</b>	Introduced on the FN IOM.
	<b>9.4(0.0)</b>	Supported on the FN I/O Aggregator.
	<b>8.3.17.0</b>	Supported on the M I/O Aggregator.

# debug ip igmp

Enable debugging of IGMP packets.

<b>Syntax</b>	<code>debug ip igmp [group address   interface]</code> To disable IGMP debugging, enter the <code>no ip igmp</code> command. To disable all debugging, enter the <code>undebug all</code> command.	
<b>Defaults</b>	Disabled	
<b>Parameters</b>	<b>group-address</b>	(OPTIONAL) Enter the IP multicast group address in dotted decimal format.
	<b>interface</b>	(OPTIONAL) Enter the interface type and slot/port information: For a VLAN interface enter the keyword <code>vlan</code> followed by a number from 1 to 4094.
<b>Command Modes</b>	EXEC Privilege	
<b>Supported Modes</b>	All Modes	
<b>Command History</b>	<b>Version</b>	<b>Description</b>
	<b>9.9(0.0)</b>	Introduced on the FN IOM.
	<b>9.4(0.0)</b>	Supported on the FN I/O Aggregator.
	<b>8.3.17.0</b>	Supported on the M I/O Aggregator.

# ip igmp group-join-limit

To limit the number of IGMP groups that can be joined in a second, use this feature.

<b>Syntax</b>	<code>ip igmp group-join-limit number</code>	
<b>Parameters</b>	<b>number</b>	Enter the number of IGMP groups permitted to join in a second. The range is from 1 to 10000.
<b>Defaults</b>	none	
<b>Command Modes</b>	CONFIGURATION ( <i>conf-if-interface-slot/port</i> )	
<b>Supported Modes</b>	Programmable-Mux (PMUX)	
<b>Command History</b>	<b>Version</b>	<b>Description</b>
	<b>9.9(0.0)</b>	Introduced on the FN IOM.
	<b>9.4(0.0)</b>	Supported on the FN I/O Aggregator.
	<b>9.2(0.0)</b>	Introduced on the M I/O Aggregator.

# ip igmp querier-timeout

Change the interval that must pass before a multicast router decides that there is no longer another multicast router that should be the querier.

<b>Syntax</b>	<code>ip igmp querier-timeout seconds</code> To return to the default value, use the <code>no ip igmp querier-timeout</code> command.	
<b>Parameters</b>	<b>seconds</b>	Enter the number of seconds the router must wait to become the new querier. The range is from 60 to 300. The default is <b>125 seconds</b> .



**Defaults** 125 seconds

**Command Modes** INTERFACE

**Supported Modes** Programmable-Mux (PMUX)

<b>Command History</b>	<b>Version</b>	<b>Description</b>
	<b>9.9(0.0)</b>	Introduced on the FN IOM.
	<b>9.4(0.0)</b>	Supported on the FN I/O Aggregator.
	<b>9.2(0.0)</b>	Introduced on the M I/O Aggregator.

## ip igmp query-interval

Change the transmission frequency of IGMP general queries the Querier sends.

**Syntax** `ip igmp query-interval seconds`  
To return to the default values, use the `no ip igmp query-interval` command.

**Parameters** *seconds* Enter the number of seconds between queries sent out. The range is from 1 to 18000. The default is **60 seconds**.

**Defaults** 60 seconds

**Command Modes** INTERFACE

**Supported Modes** Programmable-Mux (PMUX)

<b>Command History</b>	<b>Version</b>	<b>Description</b>
	<b>9.9(0.0)</b>	Introduced on the FN IOM.
	<b>9.4(0.0)</b>	Supported on the FN I/O Aggregator.
	<b>9.2(0.0)</b>	Introduced on the M I/O Aggregator.

## ip igmp query-max-resp-time

Set the maximum query response time advertised in general queries.

**Syntax** `ip igmp query-max-resp-time seconds`  
To return to the default values, use the `no ip igmp query-max-resp-time` command.

**Parameters** *seconds* Enter the number of seconds for the maximum response time. The range is from 1 to 25. The default is **10 seconds**.

**Defaults** 10 seconds

**Command Modes** INTERFACE

**Supported Modes** Programmable-Mux (PMUX)

<b>Command History</b>	<b>Version</b>	<b>Description</b>
	<b>9.9(0.0)</b>	Introduced on the FN IOM.
	<b>9.4(0.0)</b>	Supported on the FN I/O Aggregator.
	<b>9.2(0.0)</b>	Introduced on the M I/O Aggregator.

# ip igmp snooping enable

Enable IGMP snooping on all or a single VLAN. This command is the master on/off switch to enable IGMP snooping.

**Syntax** `ip igmp snooping enable`  
To disable IGMP snooping, use the `no ip igmp snooping enable` command.

**Defaults** Disabled.

**Command Modes**

- CONFIGURATION
- INTERFACE VLAN

**Supported Modes** Programmable-Mux (PMUX)

Command History	Version	Description
	<b>9.9(0.0)</b>	Introduced on the FN IOM.
	<b>9.4(0.0)</b>	Supported on the FN I/O Aggregator.
	<b>9.2(0.0)</b>	Introduced on the M I/O Aggregator.

**Usage Information** To enable IGMP snooping, enter this command. When you enable this command from CONFIGURATION mode, IGMP snooping enables on all VLAN interfaces (except the default VLAN).  
 **NOTE:** Execute the `no shutdown` command on the VLAN interface for IGMP Snooping to function.

# ip igmp snooping fast-leave

Enable IGMP snooping fast-leave for this VLAN.

**Syntax** `ip igmp snooping fast-leave`  
To disable IGMP snooping fast leave, use the `no igmp snooping fast-leave` command.

**Defaults** Not configured.

**Command Modes** INTERFACE VLAN — (conf-if-vl-n)

**Supported Modes** Programmable-Mux (PMUX)

Command History	Version	Description
	<b>9.9(0.0)</b>	Introduced on the FN IOM.
	<b>9.4(0.0)</b>	Supported on the FN I/O Aggregator.
	<b>9.2(0.0)</b>	Introduced on the M I/O Aggregator.

**Usage Information** Queriers normally send some queries when a leave message is received prior to deleting a group from the membership database. There may be situations when you require a fast deletion of a group. When you enable IGMP fast leave processing, the switch removes an interface from the multicast group as soon as it detects an IGMP version 2 leave message on the interface.

# ip igmp snooping flood

This command controls the flooding behavior of unregistered multicast data packets. When flooding is disabled, unregistered multicast data traffic is forwarded to *only* multicast router ports in a VLAN. If there is no multicast router port in a VLAN, unregistered multicast data traffic is dropped.

**Syntax** `ip igmp snooping flood`  
To disable the flooding, use the `no ip igmp snooping flood` command.

<b>Parameters</b>	Enabled
<b>Command Modes</b>	CONFIGURATION
<b>Supported Modes</b>	All Modes

<b>Command History</b>	<b>Version</b>	<b>Description</b>
	<b>9.9(0.0)</b>	Introduced on the FN IOM.
	<b>9.4(0.0)</b>	Supported on the FN I/O Aggregator.
	<b>8.3.17.0</b>	Supported on the M I/O Aggregator.

## ip igmp snooping last-member-query-interval

The last member query interval is the maximum response time inserted into Group-Specific queries sent in response to Group-Leave messages.

**Syntax** `ip igmp snooping last-member-query-interval milliseconds`

To return to the default value, use the `no ip igmp snooping last-member-query-interval` command.

**Parameters** *milliseconds* Enter the interval in milliseconds. The range is from 100 to 65535. The default is **1000 milliseconds**.

**Defaults** **1000 milliseconds**

**Command Modes** INTERFACE VLAN

**Supported Modes** Programmable-Mux (PMUX)

<b>Command History</b>	<b>Version</b>	<b>Description</b>
	<b>9.9(0.0)</b>	Introduced on the FN IOM.
	<b>9.4(0.0)</b>	Supported on the FN I/O Aggregator.
	<b>9.2(0.0)</b>	Introduced on the M I/O Aggregator.

**Usage Information** This last-member-query-interval is also the interval between successive Group-Specific Query messages. To change the last-member-query interval, use this command.

## ip igmp snooping mrouter

Statically configure a VLAN member port as a multicast router interface.

**Syntax** `ip igmp snooping mrouter interface interface`

To delete a specific multicast router interface, use the `no igmp snooping mrouter interface interface` command.

**Parameters** *interface interface*

Enter the following keywords and slot/port or number information:

- For a 100/1000 Ethernet interface, enter the keyword `gigabitethernet` followed by the slot/port information.
- For a 1-Gigabit Ethernet interface, enter the keyword `gigabitethernet` followed by the slot/port information.
- For a 10-Gigabit Ethernet interface, enter the keyword `TenGigabitEthernet` then the slot/port information.
- For a 40-Gigabit Ethernet interface, enter the keyword `fortyGigE` then the slot/port information.

- For a Port Channel interface, enter the keywords `port-channel` then a number.

**Defaults** Not configured.

**Command Modes** INTERFACE VLAN — (conf-if-vl-n)

**Supported Modes** Programmable-Mux (PMUX)

**Command History** This guide is platform-specific. For command information about other platforms, refer to the relevant *Dell Networking OS Command Line Reference Guide*.

The following is a list of the Dell Networking OS version history for this command.

Version	Description
<b>9.2(0.0)</b>	Introduced on the M I/O Aggregator.

**Usage Information** Dell Networking OS provides the capability of statically configuring the interface to which a multicast router is attached. To configure a static connection to the multicast router, enter the `ip igmp snooping mrouter interface` command in the VLAN context. The interface to the router must be a part of the VLAN where you are entering the command.

## ip igmp snooping querier

Enable IGMP querier processing for the VLAN interface.

**Syntax** `ip igmp snooping querier`

To disable IGMP querier processing for the VLAN interface, use the `no ip igmp snooping querier` command.

**Defaults** Not configured.

**Command Modes** INTERFACE VLAN — (conf-if-vl-n)

**Supported Modes** Programmable-Mux (PMUX)

Command History	Version	Description
	<b>9.9(0.0)</b>	Introduced on the FN IOM.
	<b>9.4(0.0)</b>	Supported on the FN I/O Aggregator.
	<b>9.2(0.0)</b>	Introduced on the M I/O Aggregator.

**Usage Information** This command enables the IGMP switch to send General Queries periodically. This behavior is useful when there is no multicast router present in the VLAN because the multicast traffic is not routed. Assign an IP address to the VLAN interface for the switch to act as a querier for this VLAN.

## ip igmp version

Manually set the version of the router to IGMPv2 or IGMPv3.

**Syntax** `ip igmp version {2 | 3}`

**Parameters**

<b>2</b>	Enter the number 2 to set the IGMP version number to IGMPv2.
<b>3</b>	Enter the number 3 to set the IGMP version number to IGMPv3.

**Defaults** 2 (that is, IGMPv2)

**Command Modes** INTERFACE

**Supported Modes** Programmable-Mux (PMUX)

Command History	Version	Description
	<b>9.9(0.0)</b>	Introduced on the FN IOM.
	<b>9.4(0.0)</b>	Supported on the FN I/O Aggregator.
	<b>9.2(0.0)</b>	Introduced on the M I/O Aggregator.

## show ip igmp groups

View the IGMP groups.

<b>Syntax</b>	show ip igmp groups [group-address [detail]   detail   interface [group-address [detail]]]	
<b>Parameters</b>	<b>group-address</b>	(OPTIONAL) Enter the group address in dotted decimal format to view information on that group only.
	<b>interface</b>	(OPTIONAL) Enter the interface type and slot/port information: For a VLAN interface enter the keyword vlan followed by a number from 1 to 4094.
	<b>detail</b>	(OPTIONAL) Enter the keyword detail to display the IGMPv3 source information.
<b>Command Modes</b>	<ul style="list-style-type: none"> <li>EXEC</li> <li>EXEC Privilege</li> </ul>	

**Supported Modes** All Modes

Command History	Version	Description
	<b>9.9(0.0)</b>	Introduced on the FN IOM.
	<b>9.4(0.0)</b>	Supported on the FN I/O Aggregator.
	<b>8.3.17.0</b>	Supported on the M I/O Aggregator.

### Example

```
Dell#show ip igmp groups
Total Number of Groups: 5
IGMP Connected Group Membership
Group Address Interface Mode Uptime
Expires Last Reporter
225.0.0.0 Vlan 100 IGMPv2 00:00:05
00:02:04 3.0.0.51
Member Ports: Po 2
225.0.0.2 Vlan 100 IGMPv2 00:00:05
00:02:04 3.0.0.51
Member Ports: Po 2
225.0.0.3 Vlan 100 IGMPv2 00:00:05
00:02:04 3.0.0.51
Member Ports: Po 2
225.0.0.4 Vlan 100 IGMPv2 00:00:05
00:02:04 3.0.0.51
Member Ports: Po 2
```

Field	Description
<b>Group Address</b>	Lists the multicast address for the IGMP group.
<b>Interface</b>	Lists the interface type, slot and port number.
<b>Mode</b>	Displays the IGMP version used.
<b>Uptime</b>	Displays the amount of time the group has been operational.
<b>Expires</b>	Displays the amount of time until the entry expires.

Field	Description
<b>Last Reporter</b>	Displays the IP address of the last host to be a member of the IGMP group.
<b>Member Ports</b>	Indicates the member ports of the port channel. If the port channel is VLT, an asterisk (*) after the port channel number indicates the port channel is locally down and that a remote VLT port is up.

## show ip igmp interface

View information on the interfaces participating in IGMP.

**Syntax** show ip igmp interface [*interface*]

**Parameters**

**interface** (OPTIONAL) Enter any of the following keywords and slot/port or number to clear counters from a specified interface:

- For a Port Channel interface, enter the keyword port-channel followed by a number. Range: 1-128
- For a 10-Gigabit Ethernet interface, enter the keyword TenGigabitEthernet followed by the slot/port information.
- For a VLAN, enter the keyword vlan followed by a number from 1 to 4094.

**Command Modes**

- EXEC
- EXEC Privilege

**Supported Modes** All Modes

Command History	Version	Description
	<b>9.9(0.0)</b>	Introduced on the FN IOM.
	<b>9.4(0.0)</b>	Supported on the FN I/O Aggregator.
	<b>8.3.17.0</b>	Supported on the M I/O Aggregator.

### Example

```
Dell#show ip igmp interface
Vlan 2 is up, line protocol is down
Inbound IGMP access group is not set
Interface IGMP group join rate limit is not set
IGMP snooping is enabled on interface
IGMP Snooping query interval is 60 seconds
IGMP Snooping querier timeout is 125 seconds
IGMP Snooping last member query response interval is 1000 ms
IGMP snooping fast-leave is disabled on this interface
IGMP snooping querier is disabled on this interface
Vlan 3 is up, line protocol is down
Inbound IGMP access group is not set
Interface IGMP group join rate limit is not set
IGMP snooping is enabled on interface
IGMP Snooping query interval is 60 seconds
IGMP Snooping querier timeout is 125 seconds
IGMP Snooping last member query response interval is 1000 ms
IGMP snooping fast-leave is disabled on this interface
IGMP snooping querier is disabled on this interface
--More--
```

# show ip igmp snooping mrouter

Displays multicast router interfaces.

**Syntax** `show ip igmp snooping mrouter [vlan number]`

**Parameters** **vlan *number*** Enter the keyword vlan followed by the vlan number. Range: 1 to 4094

**Command Modes**

- EXEC
- EXEC Privilege

**Supported Modes** All Modes

Command History	Version	Description
	<b>9.9(0.0)</b>	Introduced on the FN IOM.
	<b>9.4(0.0)</b>	Supported on the FN I/O Aggregator.
	<b>8.3.17.0</b>	Supported on the M I/O Aggregator.

## Example

```
Dell#show ip igmp snooping mrouter vlan 2
Interface Router Ports
Vlan 2 Po 128
Dell#
```

**Related Commands** [show ip igmp groups](#) — Use this IGMP command to view groups.

# Interfaces

This chapter defines the interface commands on the Aggregator switch.

## Topics:

- Port Interface Commands
- Port Channel Commands
- Time Domain Reflectometer (TDR) Commands
- Virtual LAN (VLAN) Commands
- auto vlan
- channel-member
- clear counters
- clear mac-address-table dynamic
- default vlan-id
- description
- feature fc
- flowcontrol
- interface
- interface ManagementEthernet
- interface port-channel
- interface range
- interface vlan
- intf-type cr4 autoneg
- keepalive
- minimum-links
- monitor interface
- mtu
- name
- negotiation auto
- remote-fault-signaling rx
- show config (INTERFACE mode)
- show config (from INTERFACE RANGE mode)
- show config (from INTERFACE VLAN mode)
- show config (from PROTOCOL LLDP mode)
- show interfaces
- show interfaces configured
- show interfaces description
- show interfaces port-channel
- show interfaces stack-unit
- show interfaces status
- show interfaces switchport
- show tdr
- show vlan
- shutdown
- source (port monitoring for 40-Gigabit Ethernet)
- speed (for 1000/10000 interfaces)
- stack-unit portmode
- wavelength
- tdr-cable-test
- vlan tagged (CMC)
- vlan untagged (CMC)



# Port Interface Commands

The following commands are for physical, loopback, and null interfaces:

- `clear counters`
- `clear mac-address-table dynamic`
- `interface range`
- `interface vlan`
- `keepalive`
- `monitor interface`
- `name`
- `show config (INTERFACE mode)`
- `show config (from INTERFACE RANGE mode)`
- `show config (from INTERFACE VLAN mode)`
- `show interfaces configured`
- `show interfaces description`
- `show interfaces stack-unit`
- `show interfaces port-channel`
- `show interfaces status`
- `show interfaces switchport`
- `show vlan`
- `shutdown`
- `speed (for 1000/10000 interfaces)`

# Port Channel Commands

A Link Aggregation Group (LAG) is a group of links that appear to a MAC client as if they were a single link according to IEEE 802.3ad. In Dell Networking OS, a LAG is referred to as a Port Channel.

- For the Aggregator, the maximum port channel ID is 128 and the maximum members per port channel is 16.

Because each port can be assigned to only one Port Channel, and each Port Channel must have at least one port, some of those nominally available Port Channels might have no function because they could have no members if there are not enough ports installed. In the Aggregator, stack members can provide those ports.

The commands in this section are specific to Port Channel interfaces:

- `auto vlan`
- `monitor interface`
- `show config (from INTERFACE RANGE mode)`
- `show interfaces port-channel`

**i** **NOTE:** The Dell Networking OS implementation of LAG or Port Channel requires that you configure a LAG on both switches manually. For information about Dell Networking OS link aggregation control protocol (LACP) for dynamic LAGs, refer to the [Link Aggregation Control Protocol \(LACP\)](#) chapter. For more information about configuring and using Port Channels, refer to the *Dell PowerEdge M I/O Aggregator Configuration Guide*

# Time Domain Reflectometer (TDR) Commands

TDR is useful for troubleshooting an interface that is not establishing a link; either it is flapping or not coming up at all. TDR detects open or short conditions of copper cables on 100/1000/10G Base-T modules.

- `tdr-cable-test`
- `show tdr`

## Important Points to Remember

- The interface and port must be enabled (configured—see the `interface` command) before running TDR. An error message is generated if you have not enabled the interface.
- The interface on the far-end device must be shut down before running TDR.
- Because TDR is an intrusive test on an interface that is not establishing a link, do not run TDR on an interface that is passing traffic.
- When testing between two devices, do not run the test on both ends of the cable.

## Virtual LAN (VLAN) Commands

The following commands configure and monitor virtual local area networks (VLANs). VLANs are a virtual interface and use many of the same commands as physical interfaces.

You can configure an IP address only on the default VLAN. FTP, TFTP, ACLs, and SNMP are not supported on a VLAN.

Occasionally, while sending broadcast traffic over multiple VLANs, state of a VLAN interface may continually switch between Master and Backup.

- `auto vlan`
- `default vlan-id`
- `name`
- `show config` (from `INTERFACE VLAN` mode)
- `show vlan`
- `vlan tagged`
- `vlan untagged`

## auto vlan

Change the port to auto or admin vlan mode (enable or disable all auto VLANs).

<b>Syntax</b>	<code>auto vlan</code> To remove membership from 4K VLAN, use the <code>no auto vlan</code> command.						
<b>Defaults</b>	none						
<b>Parameters</b>	<table><tr><td><b>description</b></td><td>Enter a text string description to identify the VLAN (80 characters maximum).</td></tr></table>	<b>description</b>	Enter a text string description to identify the VLAN (80 characters maximum).				
<b>description</b>	Enter a text string description to identify the VLAN (80 characters maximum).						
<b>Command Modes</b>	INTERFACE						
<b>Supported Modes</b>	Standalone Mode						
<b>Usage Information</b>	The <code>auto vlan</code> command adds the port as untagged to default vlan and tagged to all other 4094 VLAN.						
<b>Command History</b>	<table><thead><tr><th>Version</th><th>Description</th></tr></thead><tbody><tr><td>9.4(0.0)</td><td>Supported on the FN I/O Aggregator.</td></tr><tr><td>8.3.17.0</td><td>Supported on the M I/O Aggregator.</td></tr></tbody></table>	Version	Description	9.4(0.0)	Supported on the FN I/O Aggregator.	8.3.17.0	Supported on the M I/O Aggregator.
Version	Description						
9.4(0.0)	Supported on the FN I/O Aggregator.						
8.3.17.0	Supported on the M I/O Aggregator.						

## channel-member

Add an interface to the Port Channel, while in `INTERFACE PORTCHANNEL` mode.

<b>Syntax</b>	<code>channel-member interface</code> To delete an interface from a Port Channel, use the <code>no channel-member interface</code> command.
---------------	--

**Parameters**      *interface*      (OPTIONAL) Enter any of the following keywords and slot/port or number information:

- For a 10-Gigabit Ethernet interface, enter the keyword `TenGigabitEthernet` then the slot/port information.
- For a 40-Gigabit Ethernet interface, enter the keyword `fortyGigE` then the slot/port information.

**Defaults**      Not configured.

**Command Modes**      INTERFACE PORTCHANNEL

**Supported Modes**      Programmable-Mux (PMUX)

Command History	Version	Description
	<b>9.2(0.0)</b>	Introduced on the M I/O Aggregator.
	<b>8.3.16.1</b>	Introduced on the MXL 10/40GbE Switch IO Module.

**Usage Information**

Use the `interface port-channel` command to access this command.

You cannot add an interface to a Port Channel if the interface contains an IP address in its configuration.

Link MTU and IP MTU considerations for Port Channels are:

- All members must have the same link MTU value and the same IP MTU value.
- The Port Channel link MTU and IP MTU must be less than or equal to the link MTU and IP MTU values configured on the channel members. For example, if the members have a link MTU of 2100 and an IP MTU 2000, the Port Channel's MTU values cannot be higher than 2100 for link MTU or 2000 bytes for IP MTU.

When an interface is removed from a Port Channel with the `no channel-member` command, the interface reverts to its configuration prior to joining the Port Channel.

An interface can belong to only one Port Channel.

You can add up to 16 interfaces to a Port Channel on the MXL switch. The interfaces can be located on different line cards but must be the same physical type and speed (for example, all 10-Gigabit Ethernet interfaces). However, you can combine 100/1000 interfaces and GE interfaces in the same Port Channel.

If the Port Channel contains a mix of interfaces with 100 Mb/s speed and 1000 Mb/s speed, the software disables those interfaces whose speed does not match the speed of the first interface configured and enabled in the Port Channel. If that first interface goes down, the Port Channel does not change its designated speed; disable and re-enable the Port Channel or change the order of the channel members configuration to change the designated speed. If the Port Channel contains a mix of interfaces with 100 Mb/s speed and 1000 Mb/s speed, the software disables those interfaces whose speed does not match the speed of the first interface configured and enabled in the Port Channel. If that first interface goes down, the Port Channel does not change its designated speed; disable and re-enable the Port Channel or change the order of the channel members configuration to change the designated speed. For more information about Port Channels, refer to the *Dell Networking OS Configuration Guide*.

**Related Commands**      [interface port-channel](#) — creates a Port Channel interface.

## clear counters

Clear the counters used in the `show interfaces` commands for VLANs, and physical interfaces, or selected ones.

**Syntax**      `clear counters interface`

**Defaults**      Without a specific interface specified, the command clears all interface counters.

**Parameters**      *interface*      (OPTIONAL) Enter any of the following keywords and slot/port or number to clear counters from a specified interface:

- For the management interface on the stack-unit, enter the keyword `managementethernet` followed by slot/port information. The slot and port range is 0.
- For a 10-Gigabit Ethernet interface, enter the keyword `TenGigabitEthernet` followed by the slot/port information.
- For a Port Channel interface, enter the keyword `port-channel` followed by a number. Range: 1-128

**NOTE:** This command also enables you to clear the port configurations corresponding to a range of ports.

- You can specify multiple ports as `slot/port-range`. For example, if you want to clear the port configurations corresponding to all ports between 1 and 4, specify the port range as `show interfaces interface-type 1/1 - 4`.

**Command Modes** EXEC Privilege

**Supported Modes** All Modes

Command History	Version	Description
	<b>9.9(0.0)</b>	Introduced on the FN IOM and added support to clear the interface configurations corresponding to a range of ports.
	<b>9.4(0.0)</b>	Supported on the FN I/O Aggregator.
	<b>8.3.17.0</b>	Supported on the M I/O Aggregator.

#### Example

```
Dell#clear counters
Clear counters on all interfaces [confirm]
```

## clear mac-address-table dynamic

Clear the MAC address table of all MAC addresses learned dynamically.

**Syntax** `clear mac-address-table dynamic {interface tengigabitethernet slot/port-id}`

**Parameters** **interface** Enter the keyword `interface range` and one of the interfaces — slot/port, port-channel or VLAN number. Select the range of interfaces for bulk configuration. You can enter up to six comma separated ranges-spaces are not required between the commas. Comma-separated ranges can include VLANs, port-channels and physical interfaces.

Slot/Port information must contain a space before and after the dash. For example, `interface range tengigabitethernet 0/1 - 5` is valid; `interface range tengigabitethernet 0/1-5` is not valid.

- For a 10-Gigabit Ethernet interface, enter the keyword `TenGigabitEthernet` followed by the slot/port information.

**Command Modes** EXEC Privilege

**Supported Modes** All Modes

Command History	Version	Description
	<b>9.4(0.0)</b>	Supported on the FN I/O Aggregator.
	<b>8.3.17.0</b>	Supported on the M I/O Aggregator.

# default vlan-id

Set the default VLAN ID.

**Syntax** `default vlan-id <vlan-id>`  
To reset the default VLAN ID, use the `no default vlan-id` command.

**Defaults** none

**Command Modes** CONFIGURATION

**Supported Modes** All Modes

Command History	Version	Description
	<b>9.4(0.0)</b>	Supported on the FN I/O Aggregator.
	<b>8.3.17.0</b>	Supported on the M I/O Aggregator.

**Related commands** [show vlan](#) — Displays VLAN configuration.

## description

Assign a descriptive text string to the interface.

**Syntax** `description desc_text`  
To delete a description, enter `no description` command.

**Parameters** *desc\_text* Enter a text string up to 240 characters long.

**Defaults** No description is defined.

**Command Modes** INTERFACE

**Supported Modes** All Modes

Command History	Version	Description
	<b>9.9(0.0)</b>	Introduced on the FN IOM.
	<b>9.4(0.0)</b>	Supported on the FN I/O Aggregator.
	<b>8.3.17.0</b>	Supported on the M I/O Aggregator.

**Usage Information**

- Spaces between characters are not preserved after entering this command unless you enclose the entire description in quotation marks (“desc\_text”).
- Entering a text string after the `default vlan-id` command overwrites any previous text string configured as the description.
- The `show tdr` and `default vlan-id` commands are the only commands that you can configure on an interface that is a member of a port-channel.
- Use the `show interfaces description` command to display descriptions configured for each interface.

**Related commands** [show interfaces description](#) — Displays the description field of interfaces.

# feature fc

Enables the Fibre channel communication via the NPG functionality.

<b>Syntax</b>	<code>feature fc</code>
<b>Command Modes</b>	CONFIGURATION
<b>Default</b>	Enabled
<b>Supported Modes</b>	Programmable-Mux (PMUX)

Command History	Version	Description
	<b>9.6(0.0)</b>	Supported on the FN 2210S Aggregator and M I/O Aggregator.

# flowcontrol

Controls how the system responds to and generates 802.3x pause frames on 10G and 40Gig stack units.

**Syntax** `flowcontrol rx {off | on} tx {off | on} pause-threshold value`

<b>Parameters</b>	<b>rx on</b>	Enter the keywords <code>rx on</code> to process the received flow control frames on this port. This is the default value for the receive side.
	<b>rx off</b>	Enter the keywords <code>rx off</code> to ignore the received flow control frames on this port.
	<b>tx on</b>	Enter the keywords <code>tx on</code> to send control frames from this port to the connected device when a higher rate of traffic is received. This is the default value on the send side.
	<b>tx off</b>	Enter the keywords <code>tx off</code> so that flow control frames are not sent from this port to the connected device when a higher rate of traffic is received.
	<b>pause-threshold</b>	Enter the buffer threshold limit for generating PAUSE frames.

- Defaults**
- `rx off`
  - `tx off`

**Command Modes** INTERFACE

**Supported Modes** Programmable-Mux (PMUX)

Command History	Version	Description
	<b>9.9(0.0)</b>	Introduced on the FN IOM.
	<b>9.4(0.0)</b>	Supported on the FN I/O Aggregator.
	<b>9.2(0.0)</b>	Introduced on the M I/O Aggregator.
	<b>8.3.16.1</b>	Introduced on the MXL 10/40GbE Switch IO Module.

**Usage Information** The globally assigned 48-bit Multicast address 01-80-C2-00-00-01 is used to send and receive pause frames. To allow full-duplex flow control, stations implementing the pause operation instruct the MAC to enable the reception of frames with a destination address equal to this multicast address.

The pause:

- Starts when *either* the packet pointer or the buffer threshold is met (whichever is met first). When the discard threshold is met, packets are dropped.
- Ends when *both* the packet pointer and the buffer threshold fall below 50% of the threshold settings.

The *discard threshold* defines when the interface starts dropping the packet on the interface. This may be necessary when a connected device does not honor the flow control frame sent by the switch. The

discard threshold should be larger than the *buffer threshold* so that the buffer holds at least hold at least three packets.

### Important Points to Remember

- Do not enable `tx pause` when buffer carving is enabled. For information and assistance, consult Dell Networking TAC.
- Asymmetric flow control (`rx on tx off`, or `rx off tx on`) setting for the interface port less than 100 Mb/s speed is not permitted. The following error is returned:

```
Can't configure Asymmetric flowcontrol when speed <1G, config ignored
```

- The only configuration applicable to half duplex ports is `rx off tx off`. The following error is returned:

```
Cannot configure Asymmetric flowcontrol when speed <1G, config ignored>
```

- You cannot configure half duplex when the flow control configuration is on (default is `rx on tx on`). The following error is returned: `Cannot configure half duplex when flowcontrol is on, config ignored`

**NOTE:** The flow control must be off (`rx off tx off`) before configuring the half duplex.

### Example (partial)

```
Dell(conf-if-tengig-0/1)#show config
!
interface TenGigabitEthernet 0/1
no ip address
switchport
no negotiation auto
flowcontrol monitor session 5 rx off tx on
no shutdown
...
```

**Example (Values)** This Example shows how the Dell Networking OS negotiates the flow control values between two Dell Networking chassis connected back-to-back using 1G copper ports.

```
Configured
LocRxConf  LocTxConf  RemoteRxConf  RemoteTxConf
off         off         off           off
off         off         off           on
off         off         on            off
off         off         on            on

off         on          off           off
off         on          off           on
off         on          on            off
off         on          on            on

on          off         off           off
on          off         off           on
on          off         on            off
on          off         on            on

on          on          off           off
on          on          off           on
on          on          on            off
on          on          on            off

LocNegRx   LocNegTx   RemNegRx   RemNegTx
off         off         off         off
off         off         off         off
off         off         off         off
off         off         off         off

off         off         off         off
off         off         off         off
off         on          on          off
off         off         off         off

off         off         off         off
```

```

on      off      off      on
on      on       on       on
on      on       on       on

off     off     off     off
off     off     off     off
on      on      on      on
on      on      on      on

```

**Related Commands**

[show running-config](#) — displays the flow configuration parameters (non-default values only).  
[show interfaces](#) — displays the negotiated flow control parameters.

## interface

Configure a physical interface on the switch.

**Syntax** `interface interface`

**Parameters** ***interface*** Enter one of the following keywords and slot/port or number information:

- For a 10-Gigabit Ethernet interface, enter the keyword `TenGigabitEthernet` then the slot/port information.

**Defaults** Not configured.

**Command Modes** CONFIGURATION

**Supported Modes** All Modes

Command History	Version	Description
	<b>9.9(0.0)</b>	Introduced on the FN IOM.
	<b>9.4(0.0)</b>	Supported on the FN I/O Aggregator.
	<b>8.3.17.0</b>	Supported on the M I/O Aggregator.

**Usage Information** You cannot delete a physical interface.

By default, physical interfaces are disabled (`shutdown`) and are in Layer 3 mode. To place an interface in mode, ensure that the interface's configuration does not contain an IP address and enter the `Port Channel Commands` command. By default, in PMUX mode, the interface is shut down when the `portmode hybrid` and `switchport` are enabled.

The tunnel interface operates as an ECMP (equal cost multipath) only when the next hop to the tunnel destination is over a physical interface. If you select any other interface as the next hop to the tunnel destination, the tunnel interface does not operate as an ECMP.

**Example**

```

Dell(conf)#interface tengig 0/1
Dell(conf-if-te-0/1)#exit#

```

**Related Commands**

[interface port-channel](#) — configures a port channel.  
[interface vlan](#) — configures a VLAN.  
[show interfaces](#) — displays the interface configuration.

## interface ManagementEthernet

Configure the Management port on the system.

**Syntax** `interface ManagementEthernet slot/port`



<b>Parameters</b>	<b><i>slot/port</i></b>	Enter the keyword <code>ManagementEthernet</code> , then the slot number (0) and port number zero (0).
<b>Defaults</b>	Not configured.	
<b>Command Modes</b>	CONFIGURATION	
<b>Supported Modes</b>	All Modes	
<b>Command History</b>	<b>Version</b>	<b>Description</b>
	<b>9.9(0.0)</b>	Introduced on the FN IOM.
	<b>9.4.(0.0)</b>	Supported on the FN I/O Aggregator and M I/O Aggregator.
<b>Usage Information</b>	<p>You cannot delete a Management port.</p> <p>The Management port is enabled by default (<code>no shutdown</code>). To assign an IP address to the Management port, use the <code>ip address</code> command.</p>	
<b>Example</b>	<pre>Dell(conf)#interface managementethernet 0/0 Dell(conf-if-ma-0/0)#</pre>	

## interface port-channel

Create a Port Channel interface, which is a link aggregation group (LAG) containing physical interfaces on the Aggregator.

<b>Syntax</b>	<code>interface port-channel <i>channel-number</i></code>	
	To delete a Port Channel, use the <code>no interface port-channel <i>channel-number</i></code> command.	
<b>Parameters</b>	<b><i>channel-number</i></b>	For a Port Channel interface, enter the keywords <code>port-channel</code> then a number. The range is from 1 to 128.
<b>Defaults</b>	Not configured.	
<b>Command Modes</b>	CONFIGURATION	
<b>Supported Modes</b>	Programmable-Mux (PMUX)	
<b>Command History</b>	<b>Version</b>	<b>Description</b>
	<b>9.9(0.0)</b>	Introduced on the FN IOM.
	<b>9.4(0.0)</b>	Supported on the FN I/O Aggregator.
	<b>9.2(0.0)</b>	Introduced on the M I/O Aggregator.
	<b>8.3.16.1</b>	Introduced on the MXL 10/40GbE Switch IO Module.
<b>Usage Information</b>	<p>Port Channel interfaces are logical interfaces and can be either in Layer 2 mode (by using the <code>switchport</code> command) or Layer 3 mode (by configuring an IP address). You can add a Port Channel in Layer 2 mode to a VLAN.</p> <p>A Port Channel can contain both 100/1000 interfaces and GE interfaces. Based on the first interface configured in the Port Channel and enabled, the Dell Networking OS determines if the Port Channel uses 100 Mb/s or 1000 Mb/s as the common speed. For more information, refer to <a href="#">channel-member</a>.</p> <p>If the line card is in a Jumbo mode chassis, you can also configure the <code>mtu</code> and <code>ip mtu</code> commands. The Link MTU and IP MTU values configured on the channel members must be greater than the Link MTU and IP MTU values configured on the Port Channel interface.</p> <p> <b>NOTE:</b> In a Jumbo-enabled system, you must configure all members of a Port Channel with the same link MTU values and the same IP MTU values.</p>	

## Example

```
Dell(conf)#int port-channel 2
Dell(conf-if-po-2)#
```

## Related Commands

- [channel-member](#) — adds a physical interface to the LAG.
- [interface](#) — configures a physical interface.
- [interface vlan](#) — configures a VLAN.

# interface range

This command permits configuration of a range of interfaces to which subsequent commands are applied (bulk configuration). Using the interface range command, you can enter identical commands for a range of interface.

## Syntax

```
interface range interface, interface,...
```

To delete a description, enter `no description` command.

## Parameters

**interface,**  
**interface,...**

Enter the keyword `interface range` and one of the interfaces — slot/port, port-channel or VLAN number. Select the range of interfaces for bulk configuration. You can enter up to six comma separated ranges—spaces are not required between the commas. Comma-separated ranges can include VLANs, port-channels and physical interfaces.

Slot/Port information must contain a space before and after the dash. For example, `interface range tengigabitethernet 0/1 - 5` is valid; `interface range tengigabitethernet 0/1-5` is not valid.

- For a 10-Gigabit Ethernet interface, enter the keyword `TenGigabitEthernet` followed by the slot/port information.
- For a VLAN, enter the keyword `vlan` followed by a number from 1 to 4094.

## Defaults

none

## Command Modes

CONFIGURATION

## Supported Modes

All Modes

## Command History

### Version

8.3.17.0

### Description

Supported on the M I/O Aggregator.

## Usage

### Information

When creating an interface range, interfaces appear in the order they are entered; they are not sorted. The command verifies that interfaces are present (physical) or configured (logical). Important things to remember:

- Bulk configuration is created if at least one interface is valid.
- Non-existing interfaces are excluded from the bulk configuration with a warning message.
- The interface range prompt includes interface types with slot/port information for valid interfaces. The prompt allows for a maximum of 32 characters. If the bulk configuration exceeds 32 characters, it is represented by an ellipsis ( ... ).
- When the interface range prompt has multiple port ranges, the smaller port range is excluded from the prompt.
- If overlapping port ranges are specified, the port range is extended to the smallest start port and the biggest end port.

## Example-Bulk Configuration

### Warning Message

```
Dell(conf)#interface range tengig 2/0 - 1 , tengig 10/0 , tengig 3/0
, fa 0/0
% Warning: Non-existing ports (not configured) are ignored by
interface-range
```

### Example-Interface Range prompt with Multiple Ports

```
Dell(conf)#interface range tengig 2/0 - 23 , tengig 2/1 - 10
Dell(conf-if-range-tengig-2/0-23#
```

### Example-Interface Range prompt Overlapping Port Ranges

```
Dell(conf)#interface range tengig 2/1 - 11 , tengig 2/1 - 23
Dell(conf-if-range-tengig-2/1-23#
```

Only VLAN and port-channel interfaces created using the `interface vlan` and `vlan tagged` commands can be used in the `interface range` command.

Use the `show running-config` command to display the VLAN and port-channel interfaces. VLAN or port-channel interfaces that are not displayed in the `show running-config` command cannot be used with the bulk configuration feature of the `interface range` command. You cannot create virtual interfaces (VLAN, Port-channel) using the `interface range` command.

**NOTE:** If a range has VLAN, physical, and port-channel interfaces, only commands related to physical interfaces can be bulk configured. To configure commands specific to VLAN or port-channel, only those respective interfaces should be configured in a particular range.

### Example-Single Range Bulk Configuration

```
Dell(conf)# interface range tengigabitethernet 5/1 - 23
Dell(conf-if-range)# no shutdown
Dell(conf-if-range)#
```

### Example-Multiple Range Bulk Configuration Gigabit Ethernet and Ten Gigabit Ethernet

The following example shows how to use commas to add different interface types to the range enabling all TenGigabit Ethernet interfaces in the range 5/1 to 5/23 and both Ten Gigabit Ethernet interfaces 1/1 and 1/2.

```
Dell(conf-if)# interface range tengigabitethernet 5/1 - 23,
tengigabitethernet 1/1 - 2
Dell(conf-if-range)# no shutdown
Dell(conf-if-range)#
```

### Example-Multiple Range Bulk Configuration with VLAN and port channel

The following example shows how to use commas to add VLAN and port-channel interfaces to the range.

```
Dell(conf-if)# interface range tengigabitethernet 5/1 - 23,
tengigabitethernet 1/1 - 2,
Vlan 2 - 100 , Port 1 - 25
Dell(conf-if-range)# no shutdown
Dell(conf-if-range)#
```

### Related commands

[show config \(from INTERFACE RANGE mode\)](#)— Shows the bulk configuration interfaces.

[show interfaces status](#)— Displays a summary of interface information.

## interface vlan

Configure a VLAN. Configure the default VLAN to enable Static or DHCP IP configuration. You can configure up to 4094 VLANs.

**Syntax** `interface vlan vlan-id`

To delete a VLAN, use the `no interface vlan vlan-id` command.

**Parameters** `vlan-id` Enter 1 for the default VLAN. Enter a number as the VLAN identifier. The range is from 1 to 4096.

**Defaults** Not configured, except for the default VLAN, which is configured as VLAN 1.

**Command Modes** CONFIGURATION

**Supported Modes** All Modes

<b>Command History</b>	<table border="0"> <thead> <tr> <th style="text-align: left;"><b>Version</b></th> <th style="text-align: left;"><b>Description</b></th> </tr> </thead> <tbody> <tr> <td><b>9.9(0.0)</b></td> <td>Introduced on the FN IOM.</td> </tr> <tr> <td><b>9.4(0.0)</b></td> <td>Supported on the FN I/O Aggregator.</td> </tr> <tr> <td><b>8.3.17.0</b></td> <td>Supported on the M I/O Aggregator.</td> </tr> </tbody> </table>	<b>Version</b>	<b>Description</b>	<b>9.9(0.0)</b>	Introduced on the FN IOM.	<b>9.4(0.0)</b>	Supported on the FN I/O Aggregator.	<b>8.3.17.0</b>	Supported on the M I/O Aggregator.
<b>Version</b>	<b>Description</b>								
<b>9.9(0.0)</b>	Introduced on the FN IOM.								
<b>9.4(0.0)</b>	Supported on the FN I/O Aggregator.								
<b>8.3.17.0</b>	Supported on the M I/O Aggregator.								
<b>Usage Information</b>	<p>For more information about VLANs and the commands to configure them, refer to <a href="#">Virtual LAN (VLAN) Commands</a>.</p> <p>FTP, TFTP, and SNMP operations are not supported on a VLAN. MAC/IP ACLs are not supported.</p>								
<b>Examples</b>	<pre>Dell(conf)#int vlan 1 Dell(conf-if-vl-1)#</pre> <pre>Dell(conf)#int vlan 3 Dell(conf-if-vl-3)#</pre>								
<b>Related commands</b>	<p><a href="#">show vlan</a> — Displays the current VLAN configuration on the switch.</p> <p><a href="#">vlan tagged</a> — Adds a Layer 2 interface to a VLAN as a tagged interface.</p> <p><a href="#">vlan untagged</a> — Adds a Layer 2 interface to a VLAN as an untagged interface.</p>								

## intf-type cr4 autoneg

Set the interface type as CR4 with auto-negotiation enabled.

<b>Syntax</b>	<pre>intf-type cr4 autoneg</pre> <p>If you configure <code>intf-type cr4 autoneg</code>, use the <code>no intf-type cr4 autoneg</code> command to set the interface type as cr4 with autonegotiation disabled.</p>								
<b>Defaults</b>	Not configured								
<b>Command Modes</b>	CONFIGURATION								
<b>Supported Modes</b>	All Modes								
<b>Command History</b>	<table border="0"> <thead> <tr> <th style="text-align: left;"><b>Version</b></th> <th style="text-align: left;"><b>Description</b></th> </tr> </thead> <tbody> <tr> <td><b>9.9(0.0)</b></td> <td>Introduced on the FN IOM.</td> </tr> <tr> <td><b>9.4(0.0)</b></td> <td>Supported on the FN I/O Aggregator.</td> </tr> <tr> <td><b>8.3.17.0</b></td> <td>Supported on the M I/O Aggregator.</td> </tr> </tbody> </table>	<b>Version</b>	<b>Description</b>	<b>9.9(0.0)</b>	Introduced on the FN IOM.	<b>9.4(0.0)</b>	Supported on the FN I/O Aggregator.	<b>8.3.17.0</b>	Supported on the M I/O Aggregator.
<b>Version</b>	<b>Description</b>								
<b>9.9(0.0)</b>	Introduced on the FN IOM.								
<b>9.4(0.0)</b>	Supported on the FN I/O Aggregator.								
<b>8.3.17.0</b>	Supported on the M I/O Aggregator.								
<b>Usage Information</b>	If you configure <code>interface type</code> as CR4 with auto-negotiation enabled, also configure CR4 with auto-negotiation. Many DAC cable link issues are resolved by setting the interface type as CR4.								
<b>Related Commands</b>	<p><a href="#">interface</a> — configures a physical interface.</p> <p><a href="#">interface port-channel</a> — configures a port channel group.</p>								

## keepalive

Send keepalive packets periodically to keep an interface alive when it is not transmitting data.

<b>Syntax</b>	<pre>keepalive [seconds]</pre> <p>To stop sending keepalive packets, use the <code>no keepalive</code> command.</p>
---------------	---

**Parameters**            *seconds*            (OPTIONAL) For interfaces with PPP encapsulation enabled, enter the number of seconds between keepalive packets. The range is from 0 to 23767. The default is **10 seconds**.

**Defaults**            Enabled.

**Command Modes**    INTERFACE

**Supported Modes**    All Modes

<b>Command History</b>	<b>Version</b>	<b>Description</b>
	<b>9.9(0.0)</b>	Introduced on the FN IOM.
	<b>9.4(0.0)</b>	Supported on the FN I/O Aggregator.
	<b>9.2(0.0)</b>	Supported on the M I/O Aggregator.
	<b>8.3.16.1</b>	Introduced on the MXL 10/40GbE Switch IO Module.

**Usage Information**            When you configure `keepalive`, the system sends a self-addressed packet out of the configured interface to verify that the far end of a WAN link is up. When you configure `no keepalive`, the system does not send keepalive packets and so the local end of a WAN link remains up even if the remote end is down.

## minimum-links

Configure the minimum number of links in a LAG (Port Channel) that must be in “oper up” status for the LAG to be also in “oper up” status.

**Syntax**            `minimum-links number`

**Parameters**            *number*            Enter the number of links in a LAG that must be in “oper up” status. The range is from 1 to 16. The default is **1**.

**Defaults**            **1**

**Command Modes**    INTERFACE

**Supported Modes**    Programmable-Mux (PMUX)

<b>Command History</b>	<b>Version</b>	<b>Description</b>
	<b>9.9(0.0)</b>	Introduced on the FN IOM.
	<b>9.4(0.0)</b>	Supported on the FN I/O Aggregator.
	<b>9.2(0.0)</b>	Introduced on the M I/O Aggregator.
	<b>8.3.16.1</b>	Introduced on the MXL 10/40GbE Switch IO Module.

**Usage Information**            If you use this command to configure the minimum number of links in a LAG that must be in “oper up” status, the LAG must have at least that number of “oper up” links before it can be declared as up. For example, if the required minimum is four, and only three are up, the LAG is considered down.

## monitor interface

Monitor counters on a single interface or all interfaces on a stack unit. The screen is refreshed every five seconds and the CLI prompt disappears.

**Syntax**            `monitor interface [interface]`

To disable monitoring and return to the CLI prompt, press the `q` key.

**Parameters*****interface***

(OPTIONAL) Enter the following keywords and slot/port or number information:

- For the management port, enter the keyword `managementethernet` followed by the slot (0 or 1) and the port (0).
- For a 10-Gigabit Ethernet interface, enter the keyword `TenGigabitEthernet` followed by the slot/port information.
- For a Port Channel interface, enter the keyword `port-channel` followed by a number. The range is from 1 to 4094.

**Command Modes**

- EXEC
- EXEC Privilege

**Supported Modes** All Modes**Command History****Version****8.3.17.0****Description**

Supported on M I/O Aggregator.

**Usage Information**

The delta column displays changes since the last screen refresh.

The following are the `monitor` command menu options.**Key****Description****systest-3**

Displays the host name assigned to the system.

**monitor time**Displays the amount of time since the `monitor interface` command was entered.**time**

Displays the amount of time the chassis is up (since last reboot).

**m**

Change the view from a single interface to all interfaces on the stack unit or visa-versa.

**c**

Refresh the view.

**b**

Change the counters displayed from Packets on the interface to Bytes.

**r**

Change the [delta] column from change in the number of packets/bytes in the last interval to rate per second.

**l**

Change the view to the next interface on the stack unit, or if in the stack unit mode, the next stack unit in the chassis.

**a**

Change the view to the previous interface on the stack unit, or if in line stack unit mode, the previous stack unit in the chassis.

**T**

Increase the screen refresh rate.

**t**

Decrease the screen refresh rate.

**q**

Return to the CLI prompt.

**Example (Single Interface)**

```
systest-3 Monitor time: 00:00:06 Refresh Intvl.: 2s Time: 03:26:26
Interface: tengig 0/3, Enabled, Link is Up, Linespeed is 1000 Mbit

Traffic statistics:      Current      Rate      Delta
  Input bytes:          9069828    43 Bps    86
  Output bytes:        606915800    43 Bps    86
  Input packets:         54001      0 pps     1
  Output packets:       9401589      0 pps     1
    64B packets:         67      0 pps     0
  Over 64B packets:     49166      0 pps     1
  Over 127B packets:     350      0 pps     0
  Over 255B packets:    1351      0 pps     0
  Over 511B packets:     286      0 pps     0
  Over 1023B packets:   2781      0 pps     0
Error statistics:
  Input underruns:         0      0 pps     0
  Input giants:          0      0 pps     0
```

```

Input throttles:          0    0 pps    0
      Input CRC:          0    0 pps    0
Input IP checksum:       0    0 pps    0
      Input overrun:      0    0 pps    0
Output underruns:       0    0 pps    0
Output throttles:       0    0 pps    0

m - Change mode          c - Clear screen
l - Page up              a - Page down
T - Increase refresh interval  t - Decrease refresh interval
q - Quit

```

### Example (All Interfaces)

```

systest-3 Monitor time: 00:01:31 Refresh Intvl.: 2s Time: 03:54:14

Interface  Link   In Packets  [delta]  Out Packets
[delta]
  Gi 0/0   Down         0         0         0         0
  Gi 0/1   Down         0         0         0         0
  Gi 0/2   Up          61512     52        66160      42
  Gi 0/3   Up          63086     20       9405888     24
  Gi 0/4   Up    14697471418  2661481  13392989657
2661385
  Gi 0/5   Up           3759         3    161959604    832816
  Gi 0/6   Up           4070         3     8680346         5
  Gi 0/7   Up          61934        34    138734357        72
  Gi 0/8   Up          61427         1       59960         1
  Gi 0/9   Up          62039        53    104239232         3
  Gi 0/10  Up    17740044091    372    7373849244        79
  Gi 0/11  Up    18182889225     44    7184747584       138
  Gi 0/12  Up    18182682056         0         3682         1
  Gi 0/13  Up    18182681434     43    6592378911       144
  Gi 0/14  Up          61349        55     86281941        15
  Gi 0/15  Up          59808        58         62060        27
  Gi 0/16  Up          59889         1         61616         1
  Gi 0/17  Up           0         0    14950126    81293
  Gi 0/18  Up           0         0         0         0
  Gi 0/19  Down         0         0         0         0
  Gi 0/20  Up          62734        54         62766        18
  Gi 0/21  Up          60198         9         200899         9
  Gi 0/22  Up    17304741100  3157554  10102508511
1114221
  Gi 0/23  Up    17304769659  3139507  7133354895
523329
  m - Change mode          c - Clear screen
  b - Display bytes        r - Display pkts/bytes per sec
  l - Page up              a - Page down

```

## mtu

Set the link maximum transmission unit (MTU) (frame size) for an Ethernet interface.

**Syntax** `mtu value`

To return to the default MTU value, use the `no mtu` command.

**Parameters** **value** Enter a maximum frame size in bytes. The range is from 594 to 9252. The default is **1554**.

**Defaults** **1554**

**Command Modes** INTERFACE

**Supported Modes** Programmable-Mux (PMUX)

## Command History

Version	Description
9.9(0.0)	Introduced on the FN IOM.
9.4(0.0)	Supported on the FN I/O Aggregator.
9.2(0.0)	Introduced on the M I/O Aggregator.
8.3.16.1	Introduced on the MXL 10/40GbE Switch IO Module.

## Usage Information

If the packet includes a Layer 2 header, the difference between the link MTU and IP MTU (`ip mtu` command) must be enough bytes to include the Layer 2 header.

- The IP MTU is adjusted automatically when you configure the Layer 2 MTU with the `mtu` command.

When you enter the `no mtu` command, The Dell Networking OS reduces the IP MTU value to 1536 bytes.

Link MTU and IP MTU considerations for port channels and VLANs are as follows.

### port channels:

- All members must have the same link MTU value and the same IP MTU value.
- The port channel link MTU and IP MTU must be less than or equal to the link MTU and IP MTU values configured on the channel members. For example, if the members have a link MTU of 2100 and an IP MTU 2000, the port channel's MTU values cannot be higher than 2100 for link MTU or 2000 bytes for IP MTU.

### VLANs:

- All members of a VLAN must have same IP MTU value.
- Members can have different Link MTU values. Tagged members must have a link MTU 4 bytes higher than untagged members to account for the packet tag.
- The VLAN link MTU and IP MTU must be less than or equal to the link MTU and IP MTU values configured on the VLAN members. For example, the VLAN contains tagged members with Link MTU of 1522 and IP MTU of 1500 and untagged members with Link MTU of 1518 and IP MTU of 1500. The VLAN's Link MTU cannot be higher than 1518 bytes and its IP MTU cannot be higher than 1500 bytes.

The following shows the difference between Link MTU and IP MTU.

Layer 2 Overhead	Link MTU and IP MTU Delta
Ethernet (untagged)	18 bytes
VLAN Tag	22 bytes
Untagged Packet with VLAN-Stack Header	22 bytes
Tagged Packet with VLAN-Stack Header	26 bytes

## name

Assign a name to the Default VLAN.

**Syntax** `namevlan-name`

To remove the name from the VLAN, use the `no name` command.

**Parameters** `vlan-name` Enter up to 32 characters as the name of the VLAN.

**Defaults** Not configured.

**Command Modes** INTERFACE VLAN

**Supported Modes** All Modes



<b>Command History</b>	<table border="0"> <thead> <tr> <th style="text-align: left;">Version</th> <th style="text-align: left;">Description</th> </tr> </thead> <tbody> <tr> <td>9.4(0.0)</td> <td>Supported on the FN I/O Aggregator.</td> </tr> <tr> <td>8.3.17.0</td> <td>Supported on the M I/O Aggregator.</td> </tr> </tbody> </table>	Version	Description	9.4(0.0)	Supported on the FN I/O Aggregator.	8.3.17.0	Supported on the M I/O Aggregator.
Version	Description						
9.4(0.0)	Supported on the FN I/O Aggregator.						
8.3.17.0	Supported on the M I/O Aggregator.						
<b>Usage Information</b>	<p>This CLI applies only to the Default VLAN.</p> <p>To display information about a named VLAN, enter the <code>show vlan</code> command with the name parameter or the <code>show interfaces description</code> command.</p>						
<b>Related commands</b>	<p><a href="#">default vlan-id</a> — Assigns a descriptive text string to the interface.</p> <p><a href="#">interface vlan</a> — Configures a VLAN.</p> <p><a href="#">show vlan</a> — Displays the current VLAN configurations on the switch.</p>						

## negotiation auto

Enable auto-negotiation on an interface.

**Syntax** `negotiation auto`

To disable auto-negotiation, enter `no negotiation auto` command.

**Defaults** Enabled.

**Command Modes** INTERFACE

**Supported Modes** All Modes

<b>Command History</b>	<table border="0"> <thead> <tr> <th style="text-align: left;">Version</th> <th style="text-align: left;">Description</th> </tr> </thead> <tbody> <tr> <td>8.3.17.0</td> <td>Supported on the M I/O Aggregator</td> </tr> </tbody> </table>	Version	Description	8.3.17.0	Supported on the M I/O Aggregator
Version	Description				
8.3.17.0	Supported on the M I/O Aggregator				

**Usage Information** The `no negotiation auto` command is only available if you first manually set the speed of a port to **10Mbits** or **100Mbits**.

The `negotiation auto` command provides a mode option for configuring an individual port to forced-master/forced slave once auto-negotiation is enabled.

If the mode option is not used, the default setting is slave. If you do not configure forced-master or forced slave on a port, the port negotiates to either a master or a slave state. Port status is one of the following:

- Forced-master
- Force-slave
- Master
- Slave
- Auto-neg Error—typically indicates that both ends of the node are configured with forced-master or forced-slave

**CAUTION:** Ensure that one end of your node is configured as forced-master and one is configured as forced-slave. If both are configured the same (that is forced-master or forced-slave), the `show interfaces` command will flap between an auto-neg-error and forced-master/slave states.

You can display master/slave settings with the `show interfaces` command.

**Example (Master/Slave)**

```
Dell(conf)# interface tengig 0/0
Dell(conf-if)#neg auto
Dell(conf-if-autoneg)# ?
```

```

end          Exit from configuration mode
exit        Exit from autoneg configuration mode
mode        Specify autoneg mode
no          Negate a command or set its defaults
show        Show autoneg configuration information
Dell(conf-if-autoneg)#mode ?
forced-master Force port to master mode
forced-slave Force port to slave mode
Dell(conf-if-autoneg)#

```

### Example (Configured)

```

Dell#show interfaces configured
TenGigabitEthernet 13/18 is up, line protocol is up
Hardware is Dell Eth, address is 00:01:e8:05:f7:fc
  Current address is 00:01:e8:05:f7:fc
Interface index is 474791997
Internet address is 1.1.1.1/24
MTU 1554 bytes, IP MTU 1500 bytes
LineSpeed 1000 Mbit, Mode full duplex, Master
ARP type: ARPA, ARP Timeout 04:00:00
Last clearing of "show interfaces" counters 00:12:42
Queueing strategy: fifo
Input Statistics:
...

```

**User Information** Both sides of the link must have auto-negotiation enabled or disabled for the link to come up.

The following details the possible speed and auto-negotiation combinations for a line between two 10/100/1000 Base-T Ethernet interfaces.

#### Port 0

- auto-negotiation enabled\* speed 1000 or auto
- auto-negotiation enabled speed 100
- auto-negotiation disabled speed 100
- auto-negotiation disabled speed 100
- auto-negotiation enabled\* speed 1000 or auto

#### Port 1

- auto-negotiation enabled\* speed 1000 or auto
- auto-negotiation enabled speed 100
- auto-negotiation disabled speed 100
- auto-negotiation enabled speed 100
- auto-negotiation disabled speed 100

#### Link Status Between Port 1 and Port 2

- Up at 1000 Mb/s
- Up at 100 Mb/s
- Up at 100 Mb/s
- Down
- Down

\* You cannot disable auto-negotiation when the speed is set to 1000 or auto.

### Related Commands

[speed \(for 1000/10000 interfaces\)](#) — sets the link speed to 1000, 10000, or auto-negotiate the speed.

## remote-fault-signaling rx

Brings the interface up or down when a Remote Fault Indication (RFI) error is detected.

**Syntax** `remote-fault-signaling rx {on | off}`

**Parameters** `on` Brings the interface up when an RFI error is detected.

**off** Brings the interface down when an RFI error is detected.

**Defaults** ON.

**Command Modes** INTERFACE CONFIGURATION

**Command History** **Version 9.7(0.0)** Introduced on the M I/O Aggregator.

**Usage Information** By default, the M I/O Aggregator processes RFI errors transmitted by remote peers and brings down the interface when an RFI error is detected.

**Example**

```
Dell(conf-if-te-1/3)#remote-fault-signaling rx ?
on Enable
off Disable
```

## show config (INTERFACE mode)

Displays the interface configuration.

**Syntax** show config

**Command Modes** INTERFACE

**Supported Modes** All Modes

Command History	Version	Description
	<b>9.4(0.0)</b>	Supported on the FN I/O Aggregator.
	<b>8.3.17.0</b>	Supported on the M I/O Aggregator.

**Example**

```
Dell(conf-if)#show conf
!
interface TenGigabitEthernet 1/7
  no ip address
  switchport
  no shutdown
Dell(conf-if)#
```

## show config (from INTERFACE RANGE mode)

Display the bulk configured interfaces (group).

**Syntax** show config

**Command Modes** CONFIGURATION INTERFACE (conf-if-range)

**Supported Modes** All Modes

Command History	Version	Description
	<b>9.9(0.0)</b>	Introduced on the FN IOM.
	<b>9.4(0.0)</b>	Supported on the FN I/O Aggregator.
	<b>8.3.17.0</b>	Supported on the M I/O Aggregator.

**Example**

```
Dell(conf)#interface range tengigabitethernet 1/1 - 2
Dell(conf-if-range-tengig-1/1-2)#show config
!
interface TenGigabitEthernet 1/1
```

```

no ip address
switchport
no shutdown
!
interface TenGigabitEthernet 1/2
no ip address
switchport
no shutdown
Dell(conf-if-range-tengig-1/1-2)#

```

## show config (from INTERFACE VLAN mode)

Displays the current configuration of the Default VLAN.

**Syntax** show config

**Command Modes** INTERFACE VLAN

**Supported Modes** All Modes

Command History	Version	Description
	<b>9.4(0.0)</b>	Supported on the FN I/O Aggregator.
	<b>8.3.17.0</b>	Supported on the M I/O Aggregator.

### Example

```

Dell(conf-if-vl-1)#show config
!
interface Vlan 1
description a
no ip address
mtu 2500
shutdown
Dell(conf-if-vl-1)#

```

## show config (from PROTOCOL LLDP mode)

Displays the LLDP configuration.

**Syntax** show config

**Command Modes** PROTOCOL LLDP

**Supported Modes** All Modes

Command History	Version	Description
	<b>9.4(0.0)</b>	Supported on the FN I/O Aggregator.
	<b>8.3.17.0</b>	Supported on the M I/O Aggregator.

### Example

```

Dell(conf-lldp)#show conf
!
protocol lldp
Dell(conf-lldp)#

```

# show interfaces

Displays information on a specific physical interface or virtual interface.

**Syntax** `show interfaces interface`

**Parameters** *interface* Enter one of the following keywords and slot/port or number information:

- For the management interface on the stack-unit, enter the keyword `managementethernet` followed by slot/port information. The slot and port range is 0.
- For a 10-Gigabit Ethernet interface, enter the keyword `TenGigabitEthernet` then the slot/port information.
- For a VLAN interface, enter the keyword `vlan` followed by a number from 1 to 4094.
- For a Port Channel interface, enter the keyword `port-channel` followed by a number. The range is from 1 to 128.

**NOTE:** This command also enables you to view information corresponding to a range of ports.

- You can specify multiple ports as `slot/port-range`. For example, if you want to display information corresponding to all ports between 1 and 4, specify the port range as `show interfaces interface-type 1/1 - 4`.

**Command Modes**

- EXEC
- EXEC Privilege

**Supported Modes** All Modes

Command History	Version	Description
	9.9(0.0)	Added support to display the interface configurations corresponding to a range of ports.
	9.6(0.0)	Added support for Auto-LAG on the M I/O Aggregator.
	8.3.17.0	Supported on the M I/O Aggregator

**Usage Information** Use this `show interfaces` command for details on a specific interface. Use the `show interfaces stack-unit` command for details on all interfaces on the designated stack unit.

On the M I/O Aggregator, the show interface output displays incorrect rate information details over time for link monitoring when the rate-interval is configured for 5 seconds. Dell Networking recommends using higher rate-intervals such as 15 to 299 seconds to minimize the errors seen.

**NOTE:** In the CLI output, the power value will be rounded to a 3-digit value. For receive/transmit power that is less than 0.000, an snmp query will return the corresponding dbm value even though the CLI displays as 0.000.

**NOTE:** After the counters are cleared, the line-rate continues to increase until it reaches the maximum line rate. When the maximum line rate is reached, there will be no change in the line-rate.

**User Information** The following describes the `show interfaces` command shown in the 10G example below.

Line	Description
<b>TenGigabitEthernet 2/0...</b>	Displays the interface's type, slot/port, and administrative and line protocol status.
<b>Hardware is...</b>	Displays the interface's hardware information and its assigned MAC address.
<b>Interface index...</b>	Displays the interface index number used by SNMP to identify the interface.

Line	Description
<b>Internet address...</b>	States whether an IP address is assigned to the interface. If an IP address is assigned, that address is displayed.
<b>MTU 1554...</b>	Displays link and IP MTU information. If the chassis is in Jumbo mode, this number can range from 576 to 12000.
<b>LineSpeed</b>	Displays the interface's line speed.
<b>ARP type:...</b>	Displays the ARP type and the ARP timeout value for the interface.
<b>Last clearing...</b>	Displays the time when the <code>show interfaces</code> counters were cleared.
<b>Queuing strategy...</b>	States the packet queuing strategy. FIFO means first in first out.
<b>Input Statistics:</b>	<p>Displays all the input statistics including:</p> <ul style="list-style-type: none"> <li>• Number of packets and bytes into the interface</li> <li>• Number of packets with IP headers and VLAN tagged headers. <ul style="list-style-type: none"> <li> <b>NOTE:</b> The sum of the number of packets may not be as expected since a VLAN tagged IP packet counts as both a VLAN packet and an IP packet.</li> </ul> </li> <li>• Packet size and the number of those packets inbound to the interface</li> <li>• Number of symbol errors, runts, giants, and throttles packets: <ul style="list-style-type: none"> <li>○ symbol errors = number packets containing bad data. That is, the port MAC detected a physical coding error in the packet.</li> <li>○ runts = number of packets that are less than 64B</li> <li>○ giants = packets that are greater than the MTU size</li> <li>○ throttles = packets containing PAUSE frames</li> </ul> </li> <li>• Number of CRC, IP Checksum, overrun, and discarded packets: <ul style="list-style-type: none"> <li>○ CRC = packets with CRC/FCS errors</li> <li>○ IP Checksum = packets with IP Checksum errors</li> <li>○ overrun = number of packets discarded due to FIFO overrun conditions</li> <li>○ discarded = the sum of runts, giants, CRC, IP Checksum, and overrun packets discarded without any processing</li> </ul> </li> </ul>
<b>Output Statistics:</b>	<p>Displays output statistics sent out of the interface including:</p> <ul style="list-style-type: none"> <li>• Number of packets, bytes, and underruns out of the interface <ul style="list-style-type: none"> <li>○ packets = total number of packets</li> <li>○ bytes = total number of bytes</li> <li>○ underruns = number of packets with FIFO underrun conditions</li> </ul> </li> <li>• Number of Multicast, Broadcast, and Unicast packets: <ul style="list-style-type: none"> <li>○ Multicasts = number of MAC multicast packets</li> <li>○ Broadcasts = number of MAC broadcast packets</li> <li>○ Unicasts = number of MAC unicast packets</li> </ul> </li> <li>• Number of throttles and discards packets: <ul style="list-style-type: none"> <li>○ throttles = packets containing PAUSE frames</li> <li>○ discarded = number of packets discarded without any processing</li> </ul> </li> </ul>
<b>Rate information...</b>	Estimate of the input and output traffic rate over a designated interval (30 to 299 seconds). Traffic rate is displayed in bits, packets per second, and percent of line rate.
<b>Time since...</b>	Elapsed time since the last interface status change (hh:mm:ss format).

### Usage Information

The interface counter "over 1023-byte pkts" does not increment for packets in the range  $9216 > x < 1023$ . The Management port is enabled by default (`no shutdown`). If necessary, use the `ip address` command to assign an IP address to the Management port.

### Example 10G Port

```
Dell-IOA-A1(conf-if-te-0/1)#do show int te 0/1
TenGigabitEthernet 0/1 is up, line protocol is down(error-disabled[UFD])
Hardware is DellEth, address is f8:b1:56:07:1d:8e
```

```

Current address is f8:b1:56:07:1d:8e
Server Port AdminState is Up
Pluggable media not present
Interface index is 15274753
Internet address is not set
Mode of IPv4 Address Assignment : NONE
DHCP Client-ID :f8b156071d8e
MTU 12000 bytes, IP MTU 11982 bytes
LineSpeed auto
Auto-lag is disabled
Flowcontrol rx on tx off
ARP type: ARPA, ARP Timeout 04:00:00
Last clearing of "show interface" counters 00:12:53
Queueing strategy: fifo
Input Statistics:
    0 packets, 0 bytes
    0 64-byte pkts, 0 over 64-byte pkts, 0 over 127-byte pkts
    0 over 255-byte pkts, 0 over 511-byte pkts, 0 over 1023-byte pkts
    0 Multicasts, 0 Broadcasts
    0 runts, 0 giants, 0 throttles
    0 CRC, 0 overrun, 0 discarded
Output Statistics:
    0 packets, 0 bytes, 0 underruns
    0 64-byte pkts, 0 over 64-byte pkts, 0 over 127-byte pkts
    0 over 255-byte pkts, 0 over 511-byte pkts, 0 over 1023-byte pkts
    0 Multicasts, 0 Broadcasts, 0 Unicasts
    0 throttles, 0 discarded, 0 collisions, 0 wredrops
Rate info (interval 299 seconds):
    Input 00.00 Mbits/sec,          0 packets/sec, 0.00% of line-rate
    Output 00.00 Mbits/sec,        0 packets/sec, 0.00% of line-rate
Time since last interface status change: 00:11:36

```

### Example (ManagementEthernet)

```

Dell#show interface managementethernet ?
0/0 Management Ethernet interface number
Dell#show interface managementethernet 0/0
ManagementEthernet 0/0 is up, line protocol is up
Hardware is DellForce10Eth, address is 00:1e:c9:f1:00:05
Current address is 00:1e:c9:f1:00:05
Pluggable media not present
Interface index is 235159752
Internet address is 10.11.209.87/16
Mode of IP Address Assignment : MANUAL
DHCP Client-ID: mgmt001ec9f10005
Virtual-IP is not set
Virtual-IP IPv6 address is not set
MTU 1554 bytes, IP MTU 1500 bytes
LineSpeed 100 Mbit, Mode full duplex
ARP type: ARPA, ARP Timeout 04:00:00
Last clearing of "show interface" counters 5d4h57m
Queueing strategy: fifo
Input 3448753 packets, 950008323 bytes, 3442163 multicast
Received 0 errors, 0 discarded
Output 4627 packets, 814226 bytes, 0 multicast
Output 0 errors, 0 invalid protocol

```

### Related Commands

- [show interfaces configured](#)—Displays any interface with a non-default configuration.
- [show interfaces port-channel](#)— Displays information on all interfaces on a specific stack unit.
- [show interfaces switchport](#)— Displays Layer 2 information about the interfaces.
- [show inventory](#)— Displays the M I/O Aggregator type, components (including media), Dell Networking OS version including hardware identification numbers and configured protocols.
- [show ip interface](#)— Displays Layer 3 information about the interfaces.
- [show memory](#)— Displays the stack unit(s) status.
- [show interfaces status](#)— Displays all interfaces configured using the interface range command.

# show interfaces configured

Displays any interface with a non-default configuration.

**Syntax** `show interfaces configured`

- Command Modes**
- EXEC
  - EXEC Privilege

**Supported Modes** All Modes

Command History	Version	Description
	<b>9.9(0.0)</b>	Introduced on the FN IOM.
	<b>9.4(0.0)</b>	Supported on the FN I/O Aggregator.
	<b>8.3.17.0</b>	Supported on the M I/O Aggregator.

## Example (ManagementEthernet)

```
Dell#show interfaces configured
TenGigabitEthernet 1/1 is up, line protocol is down(error-disabled[UFD])
Hardware is DellForce10Eth, address is 00:01:e8:00:ab:01
Current address is 00:01:e8:00:ab:01
Server Port AdminState is Down
Pluggable media not present
Interface index is 67703553
Internet address is not set
Mode of IP Address Assignment : NONE
DHCP Client-ID :tenG2580001e800ab01
MTU 12000 bytes, IP MTU 11982 bytes
LineSpeed auto
Flowcontrol rx off tx off
ARP type: ARPA, ARP Timeout 04:00:00
Last clearing of "show interface" counters 05:15:07
Queueing strategy: fifo
Input Statistics:
 0 packets, 0 bytes
 0 64-byte pkts, 0 over 64-byte pkts, 0 over 127-byte pkts
 0 over 255-byte pkts, 0 over 511-byte pkts, 0 over 1023-byte pkts
 0 Multicasts, 0 Broadcasts
 0 runts, 0 giants, 0 throttles
 0 CRC, 0 overrun, 0 discarded
Output Statistics:
 0 packets, 0 bytes, 0 underruns
 0 64-byte pkts, 0 over 64-byte pkts, 0 over 127-byte pkts
 0 over 255-byte pkts, 0 over 511-byte pkts, 0 over 1023-byte pkts
 0 Multicasts, 0 Broadcasts, 0 Unicasts
 0 throttles, 0 discarded, 0 collisions, 0 wredrops
Rate info (interval 299 seconds):
Input 00.00 Mbits/sec, 0 packets/sec, 0.00% of line-rate
Output 00.00 Mbits/sec, 0 packets/sec, 0.00% of line-rate
Time since last interface status change: 05:14:12
TenGigabitEthernet 1/2 is up, line protocol is down(error-disabled[UFD])
Dell#
```

# show interfaces description

Display the descriptions configured on the interface.

**Syntax** `show interfaces [interface] description`

- Parameters** *interface*
- Enter one of the following keywords and slot/port or number information:
- For the management interface on the stack unit enter the keyword ManagementEthernet followed by the slot/port information. The slot range is 0-0 and the port range is 0.



- For a 10-Gigabit Ethernet interface, enter the keyword `TenGigabitEthernet` followed by the slot/port information.
- For VLAN interfaces, enter the keyword `vlan` followed by a number from 1 to 4094.

**NOTE:** This command also enables you to view information corresponding to a range of ports.

- You can specify multiple ports as `slot/port-range`. For example, if you want to display information corresponding to all ports between 1 and 4, specify the port range as `show interfaces interface-type 1/1 - 4`.

- Command Modes**
- EXEC
  - EXEC Privilege

**Supported Modes** All Modes

Command History	Version	Description
	<b>9.9(0.0)</b>	Introduced on the FN IOM and added support to display the interface configurations corresponding to a range of ports.
	<b>9.4(0.0)</b>	Supported on the FN I/O Aggregator.
	<b>8.3.17.0</b>	Supported on the M I/O Aggregator.

**Usage Information** The following describes the `show interfaces description` command shown in the Example below.

Field	Description
<b>Interface</b>	Displays the type of interface and associated slot and port number.
<b>OK?</b>	Indicates if the hardware is functioning properly.
<b>Status</b>	States whether the interface is enabled (up) or disabled (administratively down).
<b>Protocol</b>	States whether IP is enabled (up) or disabled (down) on the interface.
<b>Description</b>	Displays the description (if any) manually configured for the interface.

**Example**

```
Dell#show interface description
Interface          OK  Status      Protocol  Description
TenGigabitEthernet 0/1 NO  admin down  down
TenGigabitEthernet 0/2 NO  admin up    down
TenGigabitEthernet 0/3 NO  admin up    down
TenGigabitEthernet 0/4 NO  admin up    down
TenGigabitEthernet 0/5 NO  admin up    down
TenGigabitEthernet 0/6 NO  admin up    down
TenGigabitEthernet 0/7 NO  up down
TenGigabitEthernet 0/8 YES up up
```

## show interfaces port-channel

Display information on configured Port Channel groups.

**Syntax** `show interfaces port-channel [channel-number] [brief|description]`

- Parameters**
- channel-number** For a Port Channel interface, enter the keyword `port-channel` followed by a number. The range is from 1 to 128.
  - brief** (OPTIONAL) Enter the keyword `brief` to display only the port channel number, the state of the port channel, and the number of interfaces in the port channel.

**description** (OPTIONAL) Enter the keyword description to display interface information with description.

**NOTE:** This command also enables you to view information corresponding to a range of ports.

- For port-channel interfaces, you can specify multiple ports as `port-range`. For example, if you want to display information corresponding to all ports between 1 and 4, specify the port range as `show interfaces port-channel 1 - 4`.

- Command Modes**
- EXEC
  - EXEC Privilege

**Supported Modes** All Modes

**Command History**

Version	Description
9.9(0.0)	Introduced on the FN IOM and added support to display the interface configurations corresponding to a range of ports.
9.7(0.0)	Introduced on the M I/O Aggregator.
9.4(0.0)	Supported on the FN I/O Aggregator.

**Usage Information**

The following describes the `show interfaces port-channel` command shown in the following example.

Field	Description
<b>Port-Channel 1...</b>	Displays the status of LAG. In the Example, the status of the LAG, LAG fate-sharing group ("Failover-group") is listed.
<b>Hardware is...</b>	Displays the interface's hardware information and its assigned MAC address.
<b>Port-channel is part...</b>	Indicates whether the LAG is part of a LAG fate-sharing group ("Failover-group").
<b>Internet address...</b>	States whether an IP address is assigned to the interface. If an IP address is assigned, that address is displayed.
<b>MTU 1554...</b>	Displays link and IP MTU.
<b>LineSpeed</b>	Displays the interface's line speed. For a port channel interface, it is the line speed of the interfaces in the port channel.
<b>Members in this...</b>	Displays the interfaces belonging to this port channel.
<b>ARP type:...</b>	Displays the ARP type and the ARP timeout value for the interface.
<b>Last clearing...</b>	Displays the time when the <code>show interfaces</code> counters were cleared.
<b>Queueing strategy.</b>	States the packet queuing strategy. FIFO means first in first out.
<b>packets input...</b>	Displays the number of packets and bytes into the interface.
<b>Input 0 IP packets...</b>	Displays the number of packets with IP headers, VLAN tagged headers, and MPLS headers. The number of packets may not add correctly because a VLAN tagged IP packet counts as both a VLAN packet and an IP packet.
<b>0 64-byte...</b>	Displays the size of packets and the number of those packets entering that interface. This information is displayed over two lines.
<b>Received 0...</b>	Displays the type and number of errors or other specific packets received. This information is displayed over three lines.
<b>Output 0...</b>	Displays the type and number of packets sent out the interface. This information is displayed over three lines.
<b>Rate information...</b>	Displays the traffic rate information into and out of the interface. Traffic rate is displayed in bits and packets per second.

Field	Description
<b>Time since...</b>	Displays the time since the last change in the configuration of this interface.

**Example  
(EtherScale)**

```
Dell#show interfaces port-channel
Port-channel 1 is down, line protocol is down
Hardware address is 00:1e:c9:f1:00:05, Current address is
00:1e:c9:f1:00:05
Interface index is 1107755009
Minimum number of links to bring Port-channel up is 1
Internet address is not set
Mode of IP Address Assignment : NONE
DHCP Client-ID :lag1001ec9f10005
MTU 12000 bytes, IP MTU 1500 bytes
LineSpeed auto
Members in this channel:
ARP type: ARPA, ARP Timeout 04:00:00
Last clearing of "show interface" counters 03:28:00
Queueing strategy: fifo
Input Statistics:
0 packets, 0 bytes
0 64-byte pkts, 0 over 64-byte pkts, 0 over 127-byte pkts
0 over 255-byte pkts, 0 over 511-byte pkts, 0 over 1023-byte pkts
0 Multicasts, 0 Broadcasts
0 runts, 0 giants, 0 throttles
0 CRC, 0 overrun, 0 discarded
Output Statistics:
0 packets, 0 bytes, 0 underruns
0 64-byte pkts, 0 over 64-byte pkts, 0 over 127-byte pkts
0 over 255-byte pkts, 0 over 511-byte pkts, 0 over 1023-byte pkts
0 Multicasts, 0 Broadcasts, 0 Unicasts
0 throttles, 0 discarded, 0 collisions
```

**User Information** The following describes the `show interfaces port-channel brief` command shown in the following example.

Field	Description
<b>LAG</b>	Lists the port channel number.
<b>Mode</b>	Lists the mode: <ul style="list-style-type: none"> <li>• L3 — for Layer 3</li> <li>• L2 — for Layer 2</li> </ul>
<b>Status</b>	Displays the status of the port channel. <ul style="list-style-type: none"> <li>• down — if the port channel is disabled (<code>shutdown</code>)</li> <li>• up — if the port channel is enabled (<code>no shutdown</code>)</li> </ul>
<b>Uptime</b>	Displays the age of the port channel in hours:minutes:seconds.
<b>Ports</b>	Lists the interfaces assigned to this port channel.
<b>(untitled)</b>	Displays the status of the physical interfaces (up or down). <ul style="list-style-type: none"> <li>• In Layer 2 port channels, an * (asterisk) indicates which interface is the primary port of the port channel. The primary port sends out interface PDU.</li> <li>• In Layer 3 port channels, the primary port is not indicated.</li> </ul>

**Example**

```
Dell#show int po bri
Codes: L - LACP Port-channel
       O - OpenFlow Controller Port-channel
       A - Auto Port-channel
       I - Internally Lagged
LAG Mode Status Uptime Ports
L 128 L3 down 00:00:00
Dell#
```

To indicate the LACP fallback, Internally lagged is added to the list. When the LAG auto-configures itself, the LAG status describes as 'I'.

### Related Commands

`show lacp` — displays the LACP matrix.

## show interfaces stack-unit

Display information on all interfaces on a specific Aggregator stack member.

**Syntax** `show interfaces stack-unit unit-number`

**Parameters** *unit-number* Enter the stack member number (0 to 5).

**Command Modes**

- EXEC
- EXEC Privilege

**Supported Modes** All Modes

Command History	Version	Description
	<b>9.9(0.0)</b>	Introduced on the FN IOM.
	<b>9.4(0.0)</b>	Supported on the FN I/O Aggregator.
	<b>8.3.17.0</b>	Supported on the M I/O Aggregator.

### Example

```
Dell#show interfaces stack-unit 0
TenGigabitEthernet 0/1 is down, line protocol is down
Hardware is DellForce10Eth, address is 00:1e:c9:f1:00:05
Current address is 00:1e:c9:f1:00:05
Server Port AdminState is Down
Pluggable media not present
Interface index is 34148609
Internet address is not set
Mode of IP Address Assignment : NONE
DHCP Client-ID :tenG130001ec9f10005
MTU 1554 bytes, IP MTU 1500 bytes
LineSpeed auto
Flowcontrol rx off tx off
ARP type: ARPA, ARP Timeout 04:00:00
Last clearing of "show interface" counters 5d5h24m
Queueing strategy: fifo
Input Statistics:
0 packets, 0 bytes
0 64-byte pkts, 0 over 64-byte pkts, 0 over 127-byte pkts
0 over 255-byte pkts, 0 over 511-byte pkts, 0 over 1023-byte pkts
0 Multicasts, 0 Broadcasts
0 runts, 0 giants, 0 throttles
0 CRC, 0 overrun, 0 discarded
Output Statistics:
0 packets, 0 bytes, 0 underruns
0 64-byte pkts, 0 over 64-byte pkts, 0 over 127-byte pkts
0 over 255-byte pkts, 0 over 511-byte pkts, 0 over 1023-byte pkts
0 Multicasts, 0 Broadcasts, 0 Unicasts
0 throttles, 0 discarded, 0 collisions
Rate info (interval 299 seconds):
Input 00.00 Mbits/sec, 0 packets/sec, 0.00% of line-rate
Output 00.00 Mbits/sec, 0 packets/sec, 0.00% of line-rate
Time since last interface status change: 5d5h23m
!-----output truncated -----!
```

### Related Commands

`show diag` — Displays data plane and management plane input/output statistics.

# show interfaces status

Displays a summary of interface information or specify a stack unit and interface to display status information for that specific interface only.

**Syntax** `show interfaces [interface | stack-unit unit-number] status`

**Parameters**

**interface** (OPTIONAL) Enter one of the following keywords and slot/port or number information:

- For a 10-Gigabit Ethernet interface, enter the keyword `TenGigabitEthernet` followed by the slot/port information.

**unit-number** Enter the stack unit's ID number. The range is from 0 to 5.

**NOTE:** This command also enables you to view information corresponding to a range of ports.

- You can specify multiple ports as `slot/port-range`. For example, if you want to display information corresponding to all ports between 1 and 4, specify the port range as `show interfaces interface-type 1/1 - 4`.

**Defaults** none

**Command Modes**

- EXEC
- EXEC Privilege

**Supported Modes** All Modes

Command History	Version	Description
	9.9(0.0)	Introduced on the FN IOM and added support to display the interface configurations corresponding to a range of ports.
	9.4(0.0)	Supported on the FN I/O Aggregator.
	8.3.17.0	Supported on the M I/O Aggregator.

## Example

```
Dell#show interface status
Port      Description      Status      Speed      Duplex      Vlan
Te 0/1    Te 0/1            Down        Auto        Auto        --
Te 0/2    Te 0/2            Down        Auto        Auto        --
Te 0/3    Te 0/3            Down        Auto        Auto        --
Te 0/4    Te 0/4            Down        Auto        Auto        --
Te 0/5    Te 0/5            Down        Auto        Auto        --
Te 0/6    Te 0/6            Down        Auto        Auto        --
Te 0/7    Te 0/7            Down        Auto        Auto        --
Te 0/8    Te 0/8            Up 1        0000 Mbit  Full        --
Te 0/9    Te 0/9            Down        Auto        Auto        --
Te 0/10   Te 0/10           Down        Auto        Auto        --
Te 0/11   Te 0/11           Down        Auto        Auto        --
Te 0/12   Te 0/12           Down        Auto        Auto        --
Te 0/13   Te 0/13           Down        Auto        Auto        --
Te 0/14   Te 0/14           Down        Auto        Auto        --
Te 0/15   Te 0/15           Down        Auto        Auto        --
Te 0/16   Te 0/16           Up          10000 Mbit Full    --
```

# show interfaces switchport

Display only virtual and physical interfaces in Layer 2 mode. This command displays the Layer 2 mode interfaces' IEEE 802.1Q tag status and VLAN membership.

**Syntax** `show interfaces switchport [interface | stack-unit unit-id ]`

**Parameters**

**interface** (OPTIONAL) Enter one of the following keywords and slot/port or number information:

- For a 10-Gigabit Ethernet interface, enter the keyword `TenGigabitEthernet` followed by the slot/port information.
- Enter the keyword `backup` to view the backup interface for this interface.

**i** **NOTE:** This command also enables you to view information corresponding to a range of ports.

- For physical interfaces, you can specify multiple ports as `slot/port-range`. For example, if you want to display information corresponding to all ports between 1 and 4, specify the port range as `show interfaces interface-type 1/1 - 4`.
- For port-channel interfaces, you can specify multiple ports as `port-range`. For example, if you want to display information corresponding to all ports between 1 and 4, specify the port range as `show interfaces port-channel 1 - 4`.

**stack-unit *unit-id*** (OPTIONAL) Enter the keywords `stack-unit` followed by the stack member number. The range is from 0 to 5.

- Command Modes**
- EXEC
  - EXEC Privilege

**Supported Modes** All Modes

**Command History**

Version	Description
9.9(0.0)	Introduced on the FN IOM and added support to display the interface configurations corresponding to a range of ports.
9.4(0.0)	Supported on the FN I/O Aggregator.
8.3.17.0	Supported on the M I/O Aggregator.

**Usage Information**

The following describes the `show interfaces switchport` command for the following example.

Items	Description
<b>Name</b>	Displays the interface's type, slot, and port number.
<b>802.1QTagged</b>	Displays whether if the VLAN tagged ("True"), untagged ("False"), or hybrid ("Hybrid"), which supports both untagged and tagged VLANs by port 13/0.
<b>Vlan membership</b>	Lists the VLANs to which the interface is a member. Starting with Dell Networking OS version 7.6.1, this field can display native VLAN membership by port 13/0.

**Example**

```
Dell#show interfaces switchport
Codes: U - Untagged, T - Tagged
x - Dot1x untagged, X - Dot1x tagged
G - GVRP tagged, M - Trunk, H - VSN tagged
i - Internal untagged, I - Internal tagged, v - VLT untagged, V - VLT
tagged
Name: TenGigabitEthernet 1/1
802.1QTagged: Hybrid
IO-AGG port mode: Auto VLANs enabled
Vlan membership:
Q Vlans
U 1
T 2-4094
Native VlanId: 1.
Name: TenGigabitEthernet 1/2
802.1QTagged: Hybrid
IO-AGG port mode: Auto VLANs enabled
Vlan membership:
Q Vlans
U 1
T 2-4094
```

```
Native VlanId: 1.  
--More--
```

## Related Commands

[show ip interface](#) — displays Layer 3 information about the interfaces.

# show tdr

Displays the TDR test results.

**Syntax** `show tdr interface`

**Parameters** ***interface*** Enter the keyword `TenGigabitEthernet` followed by the slot/port information for the 100/1000/10 GbaseT Ethernet interface.

**Defaults** none

**Command Modes** EXEC

**Supported Modes** All Modes

## Command History

Version	Description
9.9(0.0)	Introduced on the FN IOM.
9.4(0.0)	Supported on the FN I/O Aggregator.
8.3.17.0	Supported on the M I/O Aggregator.

## Usage Information

If the TDR test has not been run, an error message is generated:

```
%Error: Please run the TDR test first
```

The following describes the TDR test status.

Status	Definition
<b>OK Status: Terminated</b>	TDR test is complete, no fault is detected on the cable, and the test is terminated.
<b>Length: 92 (+/- 1) meters, Status: Shorted</b>	A short is detected on the cable. The location, in this Example is 92 meters. The short is accurate to plus or minus one meter.
<b>Length: 93 (+/- 1) meters, Status: Open</b>	An opening is detected on the cable. The location, in this Example is 93 meters. The open is accurate to plus or minus one meter.
<b>Status: Impedance Mismatch</b>	There is an impedance mismatch in the cables.

## Example

```
Dell#show tdr tengigabitethernet 1/1  
Time since last test: 00:00:02  
Pair A, Length: OK Status: Terminated  
Pair B, Length: 92 (+/- 1) meters, Status: Short  
Pair C, Length: 93 (+/- 1) meters, Status: Open  
Pair D, Length: 0 (+/- 1) meters, Status: Impedance Mismatch
```

## Related Commands

[tdr-cable-test](#) — Runs the TDR test.

# show vlan

Displays the current VLAN configurations on the switch.

**Syntax** `show vlan [brief |id vlan-id | name vlan-name]`

- Parameters**
- brief** (OPTIONAL) Enter the keyword `brief` to display the following information:
    - VLAN ID
    - VLAN name (left blank if none is configured.)
    - Spanning Tree Group ID
    - MAC address aging time
    - IP address
  - id *vlan-id*** (OPTIONAL) Enter the keyword `id` followed by a number from 1 to 4094. Only information on the VLAN specified is displayed
  - name *vlan-name*** (OPTIONAL) Enter the keyword `name` followed by the name configured for the VLAN. Only information on the VLAN named is displayed.

- Command Modes**
- EXEC
  - EXEC Privilege

**Supported Modes** All Modes

Command History	Version	Description
	9.4(0.0)	Supported on the FN I/O Aggregator.
	8.3.17.0	Supported on the M I/O Aggregator.

**Usage Information** The following describes the `show vlan` command information given in the following example

Column Heading	Description
<b>(Column 1 — no heading)</b>	<ul style="list-style-type: none"><li>• asterisk symbol (*) = Default VLAN</li><li>• G = GVRP VLAN</li><li>• P = primary VLAN</li><li>• C = community VLAN</li><li>• I = isolated VLAN</li></ul>
<b>NUM</b>	Displays existing VLAN IDs.
<b>Status</b>	Displays the word Inactive for inactive VLANs and the word Active for active VLANs.
<b>Q</b>	Displays G for GVRP tagged, M for member of a VLAN-Stack VLAN, T for tagged interface, U (for untagged interface), x (uncapitalized x) for Dot1x untagged, or X (capitalized X) for Dot1x tagged.
<b>Ports</b>	Displays the type, slot, and port information. For the type, Po = port channel, Fo= fortygigabit ethernet, and Te = ten gigabit ethernet.

## Example

```
Dell# show vlan id 40
Codes: * - Default VLAN, G - GVRP VLANs, R - Remote Port Mirroring
        VLANs, P - Primary, C - Community, I - Isolated
Q: U - Untagged, T - Tagged
x - Dot1x untagged, X - Dot1x tagged
G - GVRP tagged, M - Vlan-stack, H - VSN tagged
i - Internal untagged, I - Internal tagged, v - VLT untagged, V
- VLT tagged
NUM Status Description Q Ports
1 Inactive a
Dell#
```



### Example (Brief)

```
Dell#show vlan brief
VLAN Name                               STG MAC Aging   IP Address
-----
1                                         0   0   0   unassigned
2                                         0   0   0   unassigned
20                                        0   0   0   unassigned
1002                                     0   0   0   unassigned
Dell#
```

### Example (Using a VLAN Name)

```
Dellconf)#interface vlan 222
Dell(conf-if-vl-222)#name test
Dell(conf-if-vl-222)#do show vlan name test
Codes: * - Default VLAN, G - GVRP VLANs
Q: U - Untagged, T - Tagged
x - Dot1x untagged, X - Dot1x tagged
G - GVRP tagged, M - Vlan-stack
NUM Status Description Q Ports
222 Inactive U TenGig 1/22
Dell(conf-if-vl-222)#
Dell#
```

### Related Commands

[interface vlan](#) — Configures a VLAN.

## shutdown

Disable an interface.

### Syntax

```
shutdown
```

To activate an interface, use the `no shutdown` command.

### Defaults

The interface is disabled.

**Command Modes** INTERFACE

**Supported Modes** All Modes

### Command History

#### Version

#### Description

**9.9(0.0)**

Introduced on the FN IOM.

**9.4(0.0)**

Supported on the FN I/O Aggregator.

**8.3.17.0**

Supported on the M I/O Aggregator.

### Usage Information

The `shutdown` command marks a physical interface as unavailable for traffic. To discover if an interface is disabled, use the `show ip interface` command. Disabled interfaces are listed as down.

Disabling a VLAN or a port channel causes different behavior. When a VLAN is disabled, the Layer 3 functions within that VLAN are disabled. Layer 2 traffic continues to flow. Entering the `shutdown` command on a port channel disables all traffic on the port channel and the individual interfaces within the port channel. To enable a port channel, you must enter `no shutdown` on the port channel interface and at least one interface within that port channel.

The `shutdown` and `description` commands are the only commands that you can configure on an interface that is a member of a port channel.

### Related Commands

[vlan tagged](#) — Test the condition of copper cables on 100/1000/10G Base-T modules.

[interface vlan](#) — Creates a VLAN.

[show ip interface](#) — Displays the interface routing status. Add the keyword `brief` to display a table of interfaces and their status.

# source (port monitoring for 40-Gigabit Ethernet)

Configure a port monitor source and destination. Starting with Dell Networking OS Release 9.3(0.0), you can also configure a 40-Gigabit Ethernet interface as the destination interface or port to which the monitored traffic is sent .

**Syntax** `source interface destination interface direction {rx | tx | both}`  
To disable a monitor source, use the `no source interface destination interface direction {rx | tx | both}` command.

**Parameters**

**interface** Enter the one of the following keywords and slot/port information:

- For a 10-Gigabit Ethernet interface, enter the keyword `TenGigabitEthernet` then the slot/port information.
- For a 40-Gigabit Ethernet interface, enter the keyword `fortyGigE` then the slot/port information.

**destination** Enter the keyword `destination` to indicate the interface destination.

**direction {rx | tx | both}** Enter the keyword `direction` then one of the packet directional indicators.

- `rx`: to monitor receiving packets only.
- `tx`: to monitor transmitting packets only.
- `both`: to monitor both transmitting and receiving packets.

**Defaults** none

**Command Modes** MONITOR SESSION (`conf-mon-sess-session-ID`)

**Supported Modes** All Modes

Command History	Version	Description
	<b>9.3(0.0)</b>	Added support for the <code>fortyGigE</code> keyword on M I/O Aggregator.
	<b>8.3.17.0</b>	Supported on M I/O Aggregator.

## Example

```
Dell(conf-mon-sess-1)# source tengigabitethernet 0/1 destination
tengigabitethernet 0/45 direction rx
Dell(conf-mon-sess-1)#
Dell(conf-mon-sess-1)#do show monitor session
  SessID  Source          Destination          Dir  Mode  Source IP
Dest IP
-----  -
1       Te 0/1                Te 0/45              rx   Port  N/A
N/A
Dell(conf-mon-sess-1)#
```

# speed (for 1000/10000 interfaces)

Set the speed for 1000/10000 interfaces. Both sides of a link must be set to the same speed (1000/10000) or to auto or the link may not come up.

**Syntax** `speed {1000 | 10000 | auto}`  
To return to the default setting, use the `no speed {1000 | 10000 | auto}` command.

**Parameters**

**1000** Enter the keyword `1000` to set the interface's speed to 1000 Mb/s.

**10000** Enter the keyword `10000` to set the interface's speed to 10000 Mb/s. Auto-negotiation is enabled.

**auto** Enter the keyword `auto` to set the interface to auto-negotiate its speed. Auto-negotiation is enabled. For more information, refer to `name`.

**Defaults** `auto`

**Command Modes** INTERFACE

**Supported Modes** All Modes

Command History	Version	Description
	<b>9.10(0.0)</b>	Added support for fanned-out 1 Gigabit SFP port.
	<b>9.4(0.0)</b>	Supported on the FN I/O Aggregator.
	<b>8.3.17.0</b>	Supported on the M I/O Aggregator.

**Usage Information**

This command is found on the 1000/10000 Base-T Ethernet interfaces.

When you enable `auto`, the system performs an automatic discovery to determine the optics installed and configure the appropriate speed.

When you configure a speed for the 1000/10000 interface, confirm the `negotiation auto` command setting. Both sides of the link must have auto-negotiation either enabled or disabled. For speed settings of 1000 or `auto`, the software sets the link to auto-negotiation and you cannot change that setting.

If you use an active optical cable (AOC), you can convert the QSFP+ port to a 10 Gigabit SFP+ port or 1 Gigabit SFP port. You can use the `speed` command to enable the required speed.

**Related Commands** `negotiation auto` — enables or disables auto-negotiation on an interface.

## stack-unit portmode

Split a single 40G port into 4-10G ports on the MXL switch.

**Syntax** `stack-unit stack-unit port number portmode quad`

**Parameters**

***stack-unit*** Enter the stack member unit identifier of the stack member to reset. The range is 0 to 5.

 **NOTE:** The MXL switch commands accept Unit ID numbers from 0 to 5, though the MXL switch supports stacking up to three units only with the Dell Networking OS version 8.3.7.1.

***number*** Enter the port number of the 40G port to be split. Enter one of the following port numbers for the MXL switch: 48, 52, 56, or 60.

**Defaults** Disabled.

**Command Modes** CONFIGURATION

**Supported Modes** Programmable-Mux (PMUX)

Command History	Version	Description
	<b>9.2(0.0)</b>	Introduced on the M I/O Aggregator.
	<b>8.3.16.1</b>	Introduced on the MXL 10/40GbE Switch IO Module.

**Usage Information**

Splitting a 40G port into 4x10G port is supported on standalone and stacked units.

- You cannot use split ports as stack-link to stack an MXL Switch.
- The split ports MXL switch unit cannot be a part of any stacked system.
- The unit number with the split ports must be the default (stack-unit 0).
- This set up can be verified using `show system brief` command. If the unit ID is different than 0, it must be renumbered to 0 before ports are split by using the `stackunit id renumber 0` command in EXEC mode.

The quad port must be in a default configuration before it can be split into 4x10G ports. The 40G port is lost in the config when the port is split, so be sure that the port is also removed from other L2/L3 feature configurations.

The system must be reloaded after issuing the CLI for the change to take effect.

## wavelength

Set the wavelength for tunable 10-Gigabit SFP+ optics.

**Syntax** `wavelength`

To retain the existing wavelength, use the `no wavelength` command.

**Defaults** none

**Command Modes** INTERFACE

**Command History** This guide is platform-specific. For command information about other platforms, see the relevant *Dell Networking OS Command Line Reference Guide*.

Version	Description
9.10(0.0)	Introduced on the S6000, S6000-ON, S5000, S4810, S4820T, S3048-ON, S4048-ON, M I/O Aggregator, FN I/O Module, MXL, C9010, S3100 series, and Z9100-ON.

**Usage Information** The wavelength can be configured only on a tunable 10-Gigabit SFP+ optic. The wavelength range is from 1528.3 nm to 1568.77nm.

If you configure the wavelength on a non-tunable optic, there is no change to the existing wavelength. The configured wavelength is saved in the running configuration and is applicable, when a tunable optic is used.

If you do not configure the wavelength on an inserted tunable optic, the existing wavelength is used.

**Example** The following example shows the wavelength set for a tunable 10-Gigabit SFP+ optic:

**Related Commands**

- [show config](#) — displays the interface configuration.

## tdr-cable-test

Test the condition of copper cables on 100/1000/10GBase-T modules.

**Syntax** `tdr-cable-test interface`

**Parameters** *interface* Enter the keyword `TenGigabitEthernet` followed by the slot/port information for the 100/1000/10GBase-T Ethernet interface.

**Defaults** none

**Command Modes** EXEC

**Supported Modes** All Modes

Command History	Version	Description
	9.9(0.0)	Introduced on the FN IOM.
	9.4(0.0)	Supported on the FN I/O Aggregator.
	8.3.17.0	Supported on the M I/O Aggregator.

**Usage Information** The interface must be enabled to run the test or an error message is generated:  
Dell#tdr-cable-test tengigabitethernet 5/2  
%Error: Interface is disabled TenGIG 5/2

**Related Commands** [show tdr](#) — Displays the results of the TDR test.

## vlan tagged (CMC)

Add a Layer 2 interface to a VLAN as a tagged interface.

**Syntax** `vlan tagged [vlan-id]`  
To remove a tagged interface from a VLAN, use the `no vlan tagged vlan-id` command.

**Parameters** **vlan-id** Enter the VLAN ID. The range is from 1 to 4094.

**Defaults** **All interfaces in Layer 2 mode are untagged.**

**Command Modes** INTERFACE

**Supported Modes** All Modes

Command History	Version	Description
	<b>9.4(0.0)</b>	Supported on the FN I/O Aggregator.
	<b>8.3.17.0</b>	Supported on the M I/O Aggregator.

**Usage Information** If the interface belongs to several VLANs, you must remove it from all VLANs to change it to an untagged interface.

Tagged interfaces can belong to multiple VLANs, while untagged interfaces can only belong to one VLAN at a time.

When two or more ports configured for VLANs form a LAG, the resulting LAG is a tagged member of all the configured VLANs and an untagged member of the VLAN to which the port with the lowest port ID belongs.

For example, if port 0/1-32 is an untagged member of VLAN 2 and port 0/41 is an untagged member of VLAN 3, the resulting LAG consisting of the two ports is an untagged member of VLAN 2 and a tagged member of VLAN3.

### Example

```
Dell(conf-if-te-0/2)#vlan tagged ?
VLAN-RANGE          Comma/Hyphen separated VLAN ID set
Dell(conf-if-te-0/2)#vlan tagged 2,3-4
Dell(conf-if-te-0/2)#show config
!
interface TenGigabitEthernet 0/2
mtu 12000
vlan tagged 2-4
!
port-channel-protocol LACP
port-channel 1 mode active
!
protocol lldp
advertise management-tlv system-name
dcbx port-role auto-downstream
no shutdown
Dell(conf-if-te-0/2)#
```

**Related Commands** [interface vlan](#) — Configures a VLAN.

[vlan untagged](#) — Specifies which interfaces in a VLAN are untagged.

# vlan untagged (CMC)

Add a Layer 2 interface to a VLAN as an untagged interface.

**Syntax** `vlan untagged [vlan-id]`  
To remove a untagged interface from a VLAN, use the `no vlan untagged [vlan-id]` command.

**Parameters** `vlan-id` Enter the VLAN ID. The range is from 1 to 4094.

**Defaults** All interfaces in Layer 2 mode are untagged.

**Command Modes** INTERFACE

**Supported Modes** All Modes

Command History	Version	Description
	9.4(0.0)	Supported on the FN I/O Aggregator.
	8.3.17.0	Supported on the M I/O Aggregator.

**Usage Information** Untagged interfaces can only belong to one VLAN.  
In the default VLAN, you cannot use the `no untagged interface` command. To remove an untagged interface from all VLANs, including the default VLAN, enter INTERFACE mode and use the `no vlan tagged` command.

Tagged interfaces can belong to multiple VLANs, while untagged interfaces can only belong to one VLAN at a time.

When two or more ports configured for VLANs form a LAG, the resulting LAG is a tagged member of all the configured VLANs and an untagged member of the VLAN to which the port with the lowest port ID belongs.

For example, if port 0/33 is an untagged member of VLAN 2 and port 0/41 is an untagged member of VLAN 3, the resulting LAG consisting of the two ports is an untagged member of VLAN 2 and a tagged member of VLANs 2 and 3.

## Example

```
Dell(conf-if-te-0/2)#vlan untagged ?
<1-4094> Untagged VLAN id
Dell(conf-if-te-0/2)#
Dell(conf-if-te-0/2)#vlan untagged 4094
Dell(conf-if-te-0/2)#show config
!
interface TenGigabitEthernet 0/2
mtu 12000
vlan untagged 4094
!
port-channel-protocol LACP
port-channel 1 mode active
!
protocol lldp
advertise management-tlv system-name
dcbx port-role auto-downstream
no shutdown
Dell(conf-if-te-0/2)#
```

**Related Commands** [interface vlan](#) — Configures a VLAN.  
[vlan tagged](#) — Specifies which interfaces in a VLAN are tagged.

# IPv4 Routing

The aggregator supports both IPv4 and IPv6 routing and these are used only for the management purpose.

This chapter describes the IPv4 related commands. They are:

- `clear tcp statistics`
- `debug ip dhcp`
- `debug ip icmp`
- `ip route`
- `management route`
- `show arp`
- `show ip management-route`
- `show ip multicast-cam stack-unit`
- `show ip interface`
- `show ip route`
- `show tcp statistics`

## Topics:

- `clear tcp statistics`
- `debug ip dhcp`
- `debug ip icmp`
- `ip route`
- `management route`
- `show arp`
- `show ip interface`
- `show ip management-route`
- `show ip multicast-cam stack-unit`
- `show ip route`
- `show tcp statistics`

## clear tcp statistics

Clear the TCP counters.

**Syntax** `clear tcp statistics`

**Command Modes** EXEC Privilege

**Supported Modes** All Modes

Command History	Version	Description
	<b>9.9(0.0)</b>	Introduced on the FN IOM.
	<b>9.4(0.0)</b>	Supported on the FN I/O Aggregator.
	<b>8.3.17.0</b>	Supported on the M I/O Aggregator.

## debug ip dhcp

Enable debug information for DHCP relay transactions and display the information on the console.

**Syntax** `debug ip dhcp`

<b>Parameters</b>	<b><i>debug ip dhcp</i></b>	To disable debug, use the no debug ip dhcp command.
<b>Defaults</b>	Debug disabled	
<b>Command Mode</b>	EXEC Privilege	
<b>Supported Modes</b>	All Modes	

<b>Command History</b>	<b>Version</b>	<b>Description</b>
	<b>9.9(0.0)</b>	Introduced on the FN IOM.
	<b>9.4(0.0)</b>	Supported on the FN I/O Aggregator.
	<b>8.3.17.0</b>	Supported on the M I/O Aggregator.

### Example

```

FTOS#debug ip dhcp
00:12:21 : %RELAY-I-PACKET: BOOTP REQUEST (Unicast) received at
interface 113.3.3.17 BOOTP
Request, hops = 0, XID = 0xbf05140f, secs = 0, hwaddr =
00:60:CF:20:7B:8C, giaddr = 0.0.0.0
00:12:21 : %RELAY-I-BOOTREQUEST: Forwarded BOOTREQUEST for
00:60:CF:20:7B:8C to 14.4.4.2
00:12:26 : %RELAY-I-PACKET: BOOTP REQUEST (Unicast) received at
interface 113.3.3.17 BOOTP
Request, hops = 0, XID = 0xbf05140f, secs = 5, hwaddr =
00:60:CF:20:7B:8C, giaddr = 0.0.0.0
00:12:26 : %RELAY-I-BOOTREQUEST: Forwarded BOOTREQUEST for
00:60:CF:20:7B:8C to 14.4.4.2
00:12:40 : %RELAY-I-PACKET: BOOTP REQUEST (Unicast) received at
interface 113.3.3.17 BOOTP
Request, hops = 0, XID = 0xda4f9503, secs = 0, hwaddr =
00:60:CF:20:7B:8C, giaddr = 0.0.0.0
00:12:40 : %RELAY-I-BOOTREQUEST: Forwarded BOOTREQUEST for
00:60:CF:20:7B:8C to 14.4.4.2
00:12:42 : %RELAY-I-PACKET: BOOTP REPLY (Unicast) received at interface
14.4.4.1 BOOTP Reply,
hops = 0, XID = 0xda4f9503, secs = 0, hwaddr = 00:60:CF:20:7B:8C, giaddr
= 113.3.3.17
00:12:42 : %RELAY-I-BOOTREPLY: Forwarded BOOTREPLY for 00:60:CF:20:7B:8C
to 113.3.3.254
00:12:42 : %RELAY-I-PACKET: BOOTP REQUEST (Unicast) received at
interface 113.3.3.17 BOOTP
Request, hops = 0, XID = 0xda4f9503, secs = 0, hwaddr =
00:60:CF:20:7B:8C, giaddr = 0.0.0.0
00:12:42 : %RELAY-I-BOOTREQUEST: Forwarded BOOTREQUEST for
00:60:CF:20:7B:8C to 14.4.4.2
00:12:42 : %RELAY-I-PACKET: BOOTP REPLY (Unicast) received at interface
14.4.4.1 BOOTP Reply,
hops = 0, XID = 0xda4f9503, secs = 0, hwaddr = 00:60:CF:20:7B:8C, giaddr
= 113.3.3.17
00:12:42 : %RELAY-I-BOOTREPLY: Forwarded BOOTREPLY for 00:60:CF:20:7B:8C
to 113.3.3.254
FTOS#

```

## debug ip icmp

View information on the internal control message protocol (ICMP).

**Syntax** `debug ip icmp [interface] [count value]`  
 To disable debugging, use the no debug ip icmp command.

**Parameters**

***interface*** (OPTIONAL) Enter the following keywords and slot/port or number information:

- For the management interface, enter the keyword ManagementEthernet then the slot/port information. The slot range is 0 and the port range is 0.



- For a 10 Gigabit Ethernet interface, enter the keyword `TenGigabitEthernet` then the slot/port information.
- For VLAN, enter the keyword `vlan` then by a number from 1 to 4094.

**count value**

(OPTIONAL) Enter the keywords `count` then the count value. The ranges from 1 to 65534. The default is **Infinity**.

**Command Modes** EXEC Privilege

**Supported Modes** All Modes

**Command History**

**Version**

**Description**

**9.9(0.0)**

Introduced on the FN IOM.

**9.4(0.0)**

Supported on the FN I/O Aggregator.

**8.3.17.0**

Supported on the M I/O Aggregator.

**Usage Information**

To stop packets from flooding the user terminal when debugging is turned on, use the `count` option.

**Example**

```
ICMP: echo request rcvd from src 40.40.40.40
ICMP: src 40.40.40.40, dst 40.40.40.40, echo reply
ICMP: src 40.40.40.40, dst 40.40.40.40, echo reply
ICMP: echo request sent to dst 40.40.40.40
ICMP: echo request rcvd from src 40.40.40.40
ICMP: src 40.40.40.40, dst 40.40.40.40, echo reply
ICMP: src 40.40.40.40, dst 40.40.40.40, echo reply
ICMP: echo request sent to dst 40.40.40.40:
```

## ip route

Assign a static route to the switch.

**Syntax**

```
ip route destination mask {ip-address | interface [ip-address]}[distance]
[permanent][tag tag-value]
```

To delete a specific static route, use the `no ip route destination mask {address | interface [ip-address]}` command.

To delete all routes matching a certain route, use the `no ip route destination mask` command.

**Parameters**

**destination**

Enter the IP address in dotted decimal format of the destination device.

**mask**

Enter the mask in the slash prefix format (/x) of the destination device's IP address.

**ip-address**

Enter the IP address in dotted decimal format of the forwarding router.

**interface**

Enter the following keywords and slot/port or number information:

- For a 10-Gigabit Ethernet interface, enter the keyword `TenGigabitEthernet` followed by the slot/port information.
- For a VLAN, enter the keyword `vlan` followed by a number from 1 to 4094.

**distance**

(OPTIONAL) Enter a number as the distance metric assigned to the route. The range is from 1 to 255.

**permanent**

(OPTIONAL) Enter the keyword `permanent` to specify the route is not removed, even if the interface assigned to that route goes down. The route must be up initially to install it in the routing table.

If you disable the interface with an IP address associated with the keyword `permanent`, the route disappears from the routing table.

**tag tag-value** (OPTIONAL) Enter the keyword `tag` followed by a number to assign to the route. The range is from 1 to 4294967295.

**Defaults** Not configured.

**Command Modes** CONFIGURATION

**Supported Modes** All Modes

Command History	Version	Description
	8.3.17.0	Supported on the M I/O Aggregator.

**Usage Information**

Using the following example of a static route: `ip route 33.33.33.0 /24 tengigabitethernet 0/0 172.31.5.43`

- The software installs a next hop that is not on the directly connected subnet but which recursively resolves to a next hop on the interface's configured subnet. In the example, if `gig 0/0` has an ip address on subnet `2.2.2.0` and if `172.31.5.43` recursively resolves to `2.2.2.0`, Dell Networking OS installs the static route.
- When the interface goes down, Dell Networking OS withdraws the route.
- When the interface comes up, Dell Networking OS re-installs the route.
- When recursive resolution is "broken," Dell Networking OS withdraws the route.
- When recursive resolution is satisfied, Dell Networking OS re-installs the route.

**Related Commands** [show ip route](#)— views the switch routing table.

## management route

Configure a static route that points to the Management interface or a forwarding router.

**Syntax** `management route {ipv4-address}/mask{forwarding-router-address | managementethernet}`

**Parameters**

***{ipv4-address}/mask*** Enter an IPv4 address (A.B.C.D) followed by the prefix-length for the IP address of the management interface.

***forwarding-router-address*** Enter an IPv4 address of a forwarding router.

***managementethernet*** Enter the keyword `managementethernet` for the Management interface.

**Defaults** Not configured.

**Command Modes** CONFIGURATION

**Supported Modes** All Modes

Command History	Version	Description
	8.3.17.0	Supported on the M I/O Aggregator.

**Usage Information**

When a static route (or a protocol route) overlaps with Management static route, the static route (or a protocol route) is preferred over the Management Static route. Also, Management static routes and the Management Connected prefix are not reflected in the hardware routing tables. Separate routing tables are maintained for IPv4 management routes. This command manages both tables.

# show arp

Displays the ARP table.

**Syntax** `show arp [interface interface | ip ip-address [mask] | macaddress mac-address [mac-address mask]] [static | dynamic] [summary]`

- Parameters**
- interface *interface*** (OPTIONAL) Enter the following keywords and slot/port or number information:
    - For the Management interface, enter the keyword `managementethernet` followed by the slot/port information.
    - For a 10-Gigabit Ethernet interface, enter the keyword `TenGigabitEthernet` followed by the slot/port information.
    - For a VLAN, enter the keyword `vlan` followed by a number from 1 to 4094.
  - ip *ip-address mask*** (OPTIONAL) Enter the keyword `ip` followed by an IP address in the dotted decimal format. Enter the optional IP address mask in the slash prefix format (`/x`).
  - macaddress *mac-address mask*** (OPTIONAL) Enter the keyword `macaddress` followed by a MAC address in `nn:nn:nn:nn:nn:nn` format. Enter the optional MAC address mask in `nn:nn:nn:nn:nn` format also.
  - static** (OPTIONAL) Enter the keyword `static` to view entries entered manually.
  - retries** (OPTIONAL) Enter the keyword `retries` to view the number of ARP retries before a 20-second back off.
  - dynamic** (OPTIONAL) Enter the keyword `dynamic` to view dynamic entries.
  - summary** (OPTIONAL) Enter the keyword `summary` to view a summary of ARP entries.
  - inspection** (OPTIONAL) Enter the keyword `inspection` to view dynamic ARP Inspection details.

**Command Modes** EXEC Privilege

**Supported Modes** All Modes

Command History	Version	Description
	8.3.17.0	Supported on the M I/O Aggregator.

**Usage Information** The following describes the `show arp` command shown in the following example.

Row Heading	Description
<b>Protocol</b>	Displays the protocol type.
<b>Address</b>	Displays the IP address of the ARP entry.
<b>Age(min)</b>	Displays the age (in minutes) of the ARP entry.
<b>Hardware Address</b>	Displays the MAC address associated with the ARP entry.
<b>Interface</b>	Displays the first two letters of the interfaces type and the slot/port associated with the ARP entry.
<b>VLAN</b>	Displays the VLAN ID, if any, associated with the ARP entry.
<b>CPU</b>	Lists which CPU the entries are stored on.

## Example

```
Dell#show arp
Protocol Address      Age (min)   Hardware Address   Interface   VLAN   CPU
-----
Internet 10.11.8.6         167        00:01:e9:45:00:03  Ma 0/0     -      CP
Internet 10.11.68.14      124        00:01:e9:45:00:03  Ma 0/0     -      CP
Internet 10.11.209.254    0          00:01:e9:45:00:03  Ma 0/0     -      CP
```

### Example (Private VLAN)

**NOTE:** In this example, Line 1 shows community VLAN 200 (in primary VLAN 10) in a PVLAN. Line 2 shows primary VLAN 10.

```
Dell#show arp
-----
Protocol Address      Age (min)  Hardware Address  Interface  VLAN  CPU
-----
Internet 5.5.5.1        -          00:01:e8:43:96:5e -          V1 10 pv 200  CP
Internet 5.5.5.10      -          00:01:e8:44:99:55 -          V1 10         CP
Internet 10.1.2.4       1          00:01:e8:d5:9e:e2 Ma 0/0     -          CP
Internet 10.10.10.4    1          00:01:e8:d5:9e:e2 Ma 0/0     -          CP
Internet 10.16.127.53  1          00:01:e8:d5:9e:e2 Ma 0/0     -          CP
Internet 10.16.134.254 20         00:01:e8:d5:9e:e2 Ma 0/0     -          CP
Internet 133.33.33.4   1          00:01:e8:d5:9e:e2 Ma 0/0     -          CP
```

### Usage Information

The following describes the `show arp summary` command shown in the following example.

#### Row Heading Description

<b>Total Entries</b>	Lists the total number of ARP entries in the ARP table.
<b>Static Entries</b>	Lists the total number of configured or static ARP entries.
<b>Dynamic Entries</b>	Lists the total number of learned or dynamic ARP entries.
<b>CPU</b>	Lists which CPU the entries are stored on.

### Example (Summary)

```
Dell#show arp summary
-----
TotalEntries Static Entries Dynamic Entries CPU
-----
3             0             3             CP
Dell#
```

## show ip interface

View IP-related information on all interfaces.

### Syntax

```
show ip interface [interface | brief] [configuration]
```

### Parameters

<b><i>interface</i></b>	(OPTIONAL) Enter the following keywords and slot/port or number information: <ul style="list-style-type: none"><li>For the Management interface, enter the keyword <code>ManagementEthernet</code> followed by zero (0).</li><li>For a Port Channel interface, enter the keywords <code>port-channel</code> followed by a number. The range is from 1 to 128.</li><li>For a 10-Gigabit Ethernet interface, enter the keyword <code>TenGigabitEthernet</code> followed by the slot/port information.</li><li>For a VLAN, enter the keyword <code>vlan</code> followed by a number from 1 to 4094.</li></ul>
<b><i>brief</i></b>	(OPTIONAL) Enter the keyword <code>brief</code> to view a brief summary of the interfaces and whether an IP address is assigned.
<b><i>configuration</i></b>	(OPTIONAL) Enter the keyword <code>configuration</code> to display the physical interfaces with non-default configurations only.

- Command Modes**
- EXEC
  - EXEC Privilege

**Supported Modes** All Modes

### Command History

Version	Description
<b>9.11(0.0)</b>	Updated the command output to include the unicast reverse path forwarding (uRPF) status.
<b>9.4(0.0)</b>	Supported on the FN I/O Aggregator.
<b>8.3.17.0</b>	Supported on the M I/O Aggregator.

## Usage Information

The following describes the `show ip interface` command shown in the following example.

Lines	Description
<b>TenGigabitEthernet 0/0...</b>	Displays the interface's type, slot/port and physical and line protocol
<b>Internet address...</b>	States whether an IP address is assigned to the interface. If one is, that address is displayed.
<b>IP MTU is...</b>	Displays IP MTU value.
<b>Inbound access...</b>	Displays the name of the any configured incoming access list. If none is configured, the phrase "not set" is displayed.
<b>Proxy ARP...</b>	States whether proxy ARP is enabled on the interface.
<b>Split horizon...</b>	States whether split horizon for RIP is enabled on the interface.
<b>Poison Reverse...</b>	States whether poison for RIP is enabled on the interface
<b>ICMP redirects...</b>	States if ICMP redirects are sent.
<b>ICMP unreachable...</b>	States if ICMP unreachable messages are sent.

## Example

```
Dell#show ip interface tengigabitethernet 0/0
TenGigabitEthernet 0/0 is down, line protocol is down
Internet address is not set
IP MTU is 1500 bytes
Inbound access list is not set
Proxy ARP is enabled
Split Horizon is enabled
Poison Reverse is disabled
ICMP redirects are not sent
ICMP unreachables are not sent
IP unicast RPF check is not supported
Dell#
```

## Usage Information

The following describes the `show ip interface brief` command shown in the following example.

Fields	Description
<b>Interface</b>	Displays type of interface and the associated slot and port number.
<b>IP-Address</b>	Displays the IP address for the interface, if configured.
<b>Ok?</b>	Indicates if the hardware is functioning properly.
<b>Method</b>	Displays "Manual" if the configuration is read from the saved configuration.
<b>Status</b>	States whether the interface is enabled (up) or disabled (administratively down).
<b>Protocol</b>	States whether IP is enabled (up) or disabled (down) on the interface.

## Example (Brief)

```
Dell#show ip interface brief
Interface          IP-Address  OK?  Method  Status  Protocol
TenGigabitEthernet 0/1 unassigned NO   None    up      down
TenGigabitEthernet 0/2 unassigned YES  None    up      up
TenGigabitEthernet 0/3 unassigned YES  None    up      up
TenGigabitEthernet 0/4 unassigned NO   None    up      down
TenGigabitEthernet 0/5 unassigned NO   None    up      down
TenGigabitEthernet 0/6 unassigned NO   None    up      down
TenGigabitEthernet 0/7 unassigned NO   None    up      down
TenGigabitEthernet 0/8 unassigned NO   None    up      down
TenGigabitEthernet 0/9 unassigned NO   None    up      down
```

# show ip management-route

View the IP addresses assigned to the Management interface.

**Syntax** `show ip management-route [all | connected | summary | static]`

- Parameters**
- all** (OPTIONAL) Enter the keyword `all` to view all IP addresses assigned to all Management interfaces on the switch.
  - connected** (OPTIONAL) Enter the keyword `connected` to view only routes directly connected to the Management interface.
  - summary** (OPTIONAL) Enter the keyword `summary` to view a table listing the number of active and non-active routes and their sources.
  - static** (OPTIONAL) Enter the keyword `static` to view non-active routes also.

- Command Modes**
- EXEC
  - EXEC Privilege

**Supported Modes** All Modes

Command History	Version	Description
	<b>9.9(0.0)</b>	Introduced on the FN IOM.
	<b>9.4(0.0)</b>	Supported on the FN I/O Aggregator.
	<b>8.3.17.0</b>	Supported on the M I/O Aggregator.

## Example

```
Dell#show ip management-route
Destination      Gateway          State
-----
10.1.2.0/24      ManagementEthernet 0/0  Connected
172.16.1.0/24    10.1.2.4        Active
Dell#
```

# show ip multicast-cam stack-unit

Displays content-addressable memory (CAM) entries.

**Syntax** `show ip multicast-cam stack-unit 0-5 port-set pipe-number [ip-address mask [longer-prefixes] | detail | member-info | summary]`

- Parameters**
- 0-5** Enter the stack-unit ID, from 0 to 5.
  - pipe-number** Enter the number of the Port-Pipe number. The range is from 0 to 0.
  - ip-address mask [longer-prefix]** (OPTIONAL) Enter the IP address and mask of a route to CAM entries for that route only.  
Enter the keyword `longer-prefixes` to view routes with a common prefix.
  - detail** Enter the keyword `detail` to display the group index ID used by the ecmp routes in the CAM.
  - member-info** Enter the keyword `member-info` to display the group index used by the ecmp, the number of egress ports (members) for the ecmp, and the port details of each member. The detail information under `member-info` will give the MAC address, VLAN ID and gateway of every member port of the ecmp.
  - summary** (OPTIONAL) Enter the keyword `summary` to view a table listing route prefixes and the total number routes which can be entered in to CAM.

- Command Modes**
- EXEC
  - EXEC Privilege

**Supported Modes** All Modes

**Command History**

Version	Description
9.9(0.0)	Introduced on the FN IOM.
9.4(0.0)	Supported on the FN I/O Aggregator.
8.3.17.0	Supported on the M I/O Aggregator.

**Usage Information**

The following describes the `show ip fib stack-unit` command shown in the following example.

Field	Description
<b>Destination</b>	Displays the destination route of the index.
<b>CG</b>	Displays 0.
<b>V</b>	Displays a 1 if the entry is valid and a 0 otherwise.
<b>C</b>	Displays the CPU bit.  1 indicates that a packet hitting this entry is forwarded to the control processor, depending on Egress port.
<b>V Id</b>	Displays the VLAN ID. If the entry is 0, the entry is not part of a VLAN.
<b>Mac Addr</b>	Displays the next-hop router's MAC address.
<b>Port</b>	Displays the egress interface. Use the second half of the entry to determine the interface. For example, in the entry 17cl CP, the CP is the pertinent portion. <ul style="list-style-type: none"> <li>• CP = control processor</li> <li>• Fo= 40 Gigabit Ethernet interface</li> <li>• Te = 10 Gigabit Ethernet interface</li> </ul>

**Example**

```
Dell#show ip multicast-cam stack-unit 0 port-set 0 10.10.10.10/32
longer-prefixes
Destination      EC      CG      V      C      VId      Mac-Addr      Port
-----
10.10.10.10      0       0       0       1       1 0 00:00:00:00:00:00      3f01 CP
Dell#
```

## show ip route

View information, including how they were learned, about the IP routes on the switch.

**Syntax**

```
show ip route [hostname | ip-address [mask] [longer-prefixes] | list
prefix-list [process-id] | connected | static | summary]
```

**Parameters**

- ip-address** (OPTIONAL) Specify a name of a device or the IP address of the device to view more detailed information about the route.
- mask** (OPTIONAL) Specify the network mask of the route. Use this parameter with the IP address parameter.
- longer-prefixes** (OPTIONAL) Enter the keywords `longer-prefixes` to view all routes with a common prefix.
- list prefix-list** (OPTIONAL) Enter the keyword `list` and the name of a configured prefix list.
- process-id** (OPTIONAL) Specify that only OSPF routes with a certain process ID must be displayed.

- connected** (OPTIONAL) Enter the keyword `connected` to view only the directly connected routes.
- static** (OPTIONAL) Enter the keyword `static` to view only routes configured by the `ip route` command.
- summary** (OPTIONAL) Enter the keyword `summary`.

- Command Modes**
- EXEC
  - EXEC Privilege

**Supported Modes** All Modes

**Command History**

Version	Description
9.9(0.0)	Introduced on the FN IOM.
9.4(0.0)	Supported on the FN I/O Aggregator.
8.3.17.0	Supported on the M I/O Aggregator.

**Usage Information**

The following describes the `show ip route all` command in the following example.

Field	Description
<b>(undefined)</b>	Identifies the type of route: <ul style="list-style-type: none"> <li>• C = connected</li> <li>• S = static</li> <li>• R = RIP</li> <li>• B = BGP</li> <li>• IN = internal BGP</li> <li>• EX = external BGP</li> <li>• LO = Locally Originated</li> <li>• O = OSPF</li> <li>• IA = OSPF inter area</li> <li>• N1 = OSPF NSSA external type 1</li> <li>• N2 = OSPF NSSA external type 2</li> <li>• E1 = OSPF external type 1</li> <li>• E2 = OSPF external type 2</li> <li>• i = IS-IS</li> <li>• L1 = IS-IS level-1</li> <li>• L2 = IS-IS level-2</li> <li>• IA = IS-IS inter-area</li> <li>• * = candidate default</li> <li>• &gt; = non-active route</li> <li>• + = summary routes</li> </ul>
<b>Destination</b>	Identifies the route's destination IP address.
<b>Gateway</b>	Identifies whether the route is directly connected and on which interface the route is configured.
<b>Dist/Metric</b>	Identifies if the route has a specified distance or metric.
<b>Last Change</b>	Identifies when the route was last changed or configured.

**Example**

**Example (Summary)**

```
Dell#show ip route summary
Route Source      Active Routes      Non-active Routes
connected         2                   0
static            1                   0
Total             3                   0
Total 3 active route(s) using 612 bytes
Dell#show ip route static ?
```



```

| Pipe through a command
Dell#show ip route static
      Destination          Gateway                Dist/Metric   Last Change
      -----
*S    0.0.0.0/0            via 10.10.91.9, Te 1/2    1/0          3d2h
Dell#

```

## show tcp statistics

View information on TCP traffic through the switch.

**Syntax** `show tcp statistics`

**Command Modes** EXEC Privilege

**Supported Modes** All Modes

Command History	Version	Description
	<b>9.9(0.0)</b>	Introduced on the FN IOM.
	<b>9.4(0.0)</b>	Supported on the FN I/O Aggregator.
	<b>8.3.17.0</b>	Supported on the M I/O Aggregator.

**Usage Information** The following describes the `show tcp statistics cp` command shown in the following example.

Field	Description
<b>Rcvd:</b>	Displays the number and types of TCP packets received by the switch. <ul style="list-style-type: none"> <li>Total = total packets received</li> <li>no port = number of packets received with no designated port</li> </ul>
<b>0 checksum error...</b>	Displays the number of packets received with the following: <ul style="list-style-type: none"> <li>checksum errors</li> <li>bad offset to data</li> <li>too short</li> </ul>
<b>329 packets...</b>	Displays the number of packets and bytes received in sequence.
<b>17 dup...</b>	Displays the number of duplicate packets and bytes received.
<b>0 partially...</b>	Displays the number of partially duplicated packets and bytes received.
<b>7 out-of-order...</b>	Displays the number of packets and bytes received out of order.
<b>0 packets with data after window</b>	Displays the number of packets and bytes received that exceed the switch's window size.
<b>0 packets after close</b>	Displays the number of packet received after the TCP connection was closed.
<b>0 window probe packets...</b>	Displays the number of window probe and update packets received.
<b>41 dup ack...</b>	Displays the number of duplicate acknowledgement packets and acknowledgement packets with data received.
<b>10184 ack...</b>	Displays the number of acknowledgement packets and bytes received.
<b>Sent:</b>	Displays the total number of TCP packets sent and the number of urgent packets sent.
<b>25 control packets...</b>	Displays the number of control packets sent and the number retransmitted.

Field	Description
<b>11603 data packets...</b>	Displays the number of data packets sent.
<b>24 data packets retransmitted</b>	Displays the number of data packets resent.
<b>355 ack..</b>	Displays the number of acknowledgement packets sent and the number of packet delayed.
<b>0 window probe...</b>	Displays the number of window probe and update packets sent.
<b>7 Connections initiated...</b>	Displays the number of TCP connections initiated, accepted, and established.
<b>14 Connections closed...</b>	Displays the number of TCP connections closed, dropped.
<b>20 Total rxmt...</b>	Displays the number of times the switch tried to re-send data and the number of connections dropped during the TCP retransmit timeout period.
<b>0 Keepalive....</b>	Lists the number of keepalive packets in timeout, the number keepalive probes and the number of TCP connections dropped during keepalive.

### Example

```
Dell#show tcp statistics

Rcvd: 9849 Total, 0 no port
0 checksum error, 0 bad offset, 0 too short
5735 packets (7919 bytes) in sequence
20 dup packets (2 bytes)
0 partially dup packets (0 bytes)
1 out-of-order packets (0 bytes)
0 packets ( 0 bytes) with data after window
0 packets after close
0 window probe packets, 0 window update packets
0 dup ack packets, 0 ack packets with unsend data
6671 ack packets (152813 bytes)
Sent: 6778 Total, 0 urgent packets
7 control packets
6674 data packets (152822 bytes)
12 data packets (1222 bytes) retransmitted
85 ack only packets (5677 delayed)
0 window probe packets, 0 window update packets
0 Connections initiated, 7 connections accepted, 7 connections
established
8 Connections closed (including 4 dropped, 0 embryonic dropped)
12 Total rxmt timeout, 1 connections dropped in rxmt timeout
26 Keepalive timeout, 25 keepalive probe, 1 Connections dropped in
keepalive
Dell#
```

# iSCSI Optimization

Internet small computer system interface (iSCSI) optimization enables quality-of-service (QoS) treatment for iSCSI storage traffic on an Aggregator.

**i** **NOTE:** When iSCSI storage devices are detected on the server-ports, storm-control is disabled on those ports. When the iSCSI devices are off the ports, storm-control is enabled again.

## Topics:

- [advertise dcbx-app-tlv](#)
- [iscsi aging time](#)
- [iscsi cos](#)
- [iscsi enable](#)
- [iscsi priority-bits](#)
- [iscsi profile-compellent](#)
- [iscsi target port](#)
- [show iscsi](#)
- [show iscsi sessions](#)
- [show iscsi sessions detailed](#)

## advertise dcbx-app-tlv

Configure DCBX to send iSCSI TLV advertisements.

**Syntax** `advertise dcbx-app-tlv iscsi`  
To disable DCBX iSCSI TLV advertisements, use the `no advertise dcbx-app-tlv iscsi` command.

**Defaults** Disabled.

**Command Modes** PROTOCOL LLDP

**Supported Modes** Programmable-Mux (PMUX)

Command History	Version	Description
	<b>9.9(0.0)</b>	Introduced on the FN IOM.
	<b>9.4(0.0)</b>	Supported on the FN I/O Aggregator.
	<b>9.2(0.0)</b>	Introduced on the M I/O Aggregator.
	<b>8.3.16.1</b>	Introduced on the MXL 10/40GbE Switch IO Module.

**Usage Information** You can configure iSCSI TLVs to send either globally or on a specified interface. The interface configuration takes priority over global configuration.

## iscsi aging time

Set the aging time for iSCSI sessions.

**Syntax** `iscsi aging time time`  
To remove the iSCSI session aging time, use the `no iscsi aging time` command.

<b>Parameters</b>	<b>time</b>	Enter the aging time for the iSCSI session. The range is from 5 to 43,200 minutes.
<b>Defaults</b>	<b>10 minutes</b>	
<b>Command Modes</b>	CONFIGURATION	
<b>Supported Modes</b>	Programmable-Mux (PMUX)	
<b>Command History</b>	<b>Version</b>	<b>Description</b>
	<b>9.9(0.0)</b>	Introduced on the FN IOM.
	<b>9.4(0.0)</b>	Supported on the FN I/O Aggregator.
	<b>9.2(0.0)</b>	Introduced on the M I/O Aggregator.
	<b>8.3.16.1</b>	Introduced on the MXL 10/40GbE Switch IO Module.

## iscsi cos

Set the QoS policy that is applied to the iSCSI flows.

**Syntax** `iscsi cos {enable | disable | dot1p vlan-priority-value [remark] | dscp dscp-value [remark]}`

To disable the QoS policy, use the `no iscsi cos dscp` command.

<b>Parameters</b>	<b>enable</b>	Enter the keyword <code>enable</code> to allow the application of preferential QoS treatment to iSCSI traffic so that the iSCSI packets are scheduled in the switch with a dot1p priority 4 regardless of the VLAN priority tag in the packet. The default is: the iSCSI packets are handled with dotp1 priority 4 without remark.
	<b>disable</b>	Enter the keyword <code>disable</code> to disable the application of preferential QoS treatment to iSCSI frames.
	<b>dot1p vlan-priority-value</b>	Enter the dot1p value of the VLAN priority tag assigned to the incoming packets in an iSCSI session. The range is from 0 to 7. The default is the dot1p value in ingress iSCSI frames is not changed and is the same priority is used in iSCSI TLV advertisements if you did not enter the <code>iscsi priority-bits</code> command.
	<b>dscp dscp-value</b>	Enter the DSCP value assigned to the incoming packets in an iSCSI session. The valid range is from 0 to 63. The default is: the DSCP value in ingress packets is not changed.
	<b>remark</b>	Marks the incoming iSCSI packets with the configured dot1p or DSCP value when they egress to the switch. The default is: the dot1and DSCP values in egress packets are not changed.

**Defaults** The default dot1p VLAN priority value is 4 without the `remark` option.

**Command Modes** CONFIGURATION

**Supported Modes** Programmable-Mux (PMUX)

<b>Command History</b>	<b>Version</b>	<b>Description</b>
	<b>9.9(0.0)</b>	Introduced on the FN IOM.
	<b>9.4(0.0)</b>	Supported on the FN I/O Aggregator.
	<b>9.2(0.0)</b>	Introduced on the M I/O Aggregator.
	<b>8.3.16.1</b>	Introduced on the MXL 10/40GbE Switch IO Module.

## iscsi enable

Globally enable iSCSI optimization.

**Syntax** `iscsi enable`

To disable iSCSI optimization, use the `no iscsi enable` command.

**Parameters** ***enable*** Enter the keyword `enable` to enable the iSCSI optimization feature.

**Defaults** Disabled.

**Command Modes** CONFIGURATION

**Supported Modes** Programmable-Mux (PMUX)

Command History	Version	Description
	<b>9.9(0.0)</b>	Introduced on the FN IOM.
	<b>9.4(0.0)</b>	Supported on the FN I/O Aggregator.
	<b>9.2(0.0)</b>	Introduced on the M I/O Aggregator.
	<b>8.3.16.1</b>	Introduced on the MXL 10/40GbE Switch IO Module.

**Usage Information** When you enable the iSCSI feature using the `iscsi enable` command, flow control settings are set to `rx on tx off` on all interfaces.

## iscsi priority-bits

Configure the iSCSI priority advertised for the iSCSI protocol in application priority TLVs.

**Syntax** `iscsi priority-bits priority-bitmap`

To remove the configured iSCSI priority, use the `no iscsi priority-bits` command.

**Parameters** ***priority-bitmap*** Enter the priority-bitmap range. The range is from 1 to FF.

**Defaults** 0x10

**Command Modes** PROTOCOL LLDP

**Supported Modes** Programmable-Mux (PMUX)

Command History	Version	Description
	<b>9.9(0.0)</b>	Introduced on the FN IOM.
	<b>9.4(0.0)</b>	Supported on the FN I/O Aggregator.
	<b>9.2(0.0)</b>	Introduced on the M I/O Aggregator.
	<b>8.3.16.1</b>	Introduced on the MXL 10/40GbE Switch IO Module.

**Usage Information** This command is available at the global level only.

## iscsi profile-compellent

Configure the auto-detection of Dell Compellent arrays on a port.

**Syntax** `iscsi profile-compellent`

**Defaults** Dell Compellent disk arrays are not detected.

**Command Modes** INTERFACE

**Supported Modes** Programmable-Mux (PMUX)

Command History	Version	Description
	<b>9.9(0.0)</b>	Introduced on the FN IOM.
	<b>9.4(0.0)</b>	Supported on the FN I/O Aggregator.
	<b>9.2(0.0)</b>	Introduced on the M I/O Aggregator.
	<b>8.3.16.1</b>	Introduced on the MXL 10/40GbE Switch IO Module.

## iscsi target port

Configure the iSCSI target ports and optionally, the IP addresses on which iSCSI communication is monitored.

**Syntax** `iscsi target port [tcp-port-2...tcp-port-16]ip-address [ip-address]`  
To remove the configured iSCSI target ports or IP addresses, use the `no iscsi target port` command.

**Parameters**

<b><i>tcp-port-2...tcpport-16</i></b>	Enter the tcp-port number of the iSCSI target ports. The <code>tcp-port-n</code> is the TCP port number or a list of TCP port numbers on which the iSCSI target listens to requests. Separate port numbers with a comma. The default is <b>860, 3260</b> .
<b><i>ip-address</i></b>	(Optional) Enter the ip-address that the iSCSI monitors. The ip-address specifies the IP address of the iSCSI target.

**Defaults** **860, 3260**

**Command Modes** CONFIGURATION

**Supported Modes** Programmable-Mux (PMUX)

Command History	Version	Description
	<b>9.9(0.0)</b>	Introduced on the FN IOM.
	<b>9.4(0.0)</b>	Supported on the FN I/O Aggregator.
	<b>9.2(0.0)</b>	Introduced on the M I/O Aggregator.
	<b>8.3.16.1</b>	Introduced on the MXL 10/40GbE Switch IO Module

**Usage Information** You can configure up to 16 target TCP ports on the switch in one command or multiple commands.

When you use the `no iscsi target port` command and the TCP port you wish to delete is one bound to a specific IP address, the IP address value must be included in the command.

## show iscsi

Display the currently configured iSCSI settings.

**Syntax** `show iscsi`

**Command Modes**

- EXEC
- EXEC Privilege

**Supported Modes** All Modes

**Command History**

Version	Description
9.9(0.0)	Introduced on the FN IOM.
9.4(0.0)	Supported on the FN I/O Aggregator.
8.3.17.0	Supported on the M I/O Aggregator.

**Example**

```
Dell#show iscsi
iSCSI is enabled
iSCSI session monitoring is enabled
iSCSI COS : dot1p is 4 no-remark
Session aging time: 10
Maximum number of connections is 256
-----
iSCSI Targets and TCP Ports:
-----
TCP Port      Target IP Address
3260
860
Dell#
```

**Related Commands**

- [show iscsi sessions](#) — displays information on active iSCSI sessions on the switch that have been established since the last reload.
- [show iscsi sessions detailed](#) — displays detailed information on active iSCSI sessions on the switch.

## show iscsi sessions

Display information on active iSCSI sessions on the switch that have been established since the last reload.

**Syntax** `show iscsi sessions`

- Command Modes**
- EXEC
  - EXEC Privilege

**Supported Modes** All Modes

**Command History**

Version	Description
9.9(0.0)	Introduced on the FN IOM.
9.4(0.0)	Supported on the FN I/O Aggregator.
8.3.17.0	Supported on the M I/O Aggregator.

**Example**

```
Dell# show iscsi sessions
Session 0:

Target: iqn.2001-05.com.equallogic:0-8a0906-0e70c2002-10a0018426a48c94-
iom010
Initiator: iqn.1991-05.com.microsoft:win-x918v27yajg
ISID: 400001370000

Session 1:

Target: iqn.2001-05.com.equallogic:0-8a0906-0f60c2002-0360018428d48c94-
iom011
Initiator: iqn.1991-05.com.microsoft:win-x918v27yajg
ISID: 400001370000.
```

**Related Commands**

- [show iscsi](#) — displays the currently configured iSCSI settings.
- [show iscsi sessions detailed](#) — displays detailed information on active iSCSI sessions on the switch.

# show iscsi sessions detailed

Displays detailed information on active iSCSI sessions on the switch.

**Syntax** `show iscsi sessions detailed [session isid]`

**Parameters** *isid* Enter the session's iSCSI ID to display detailed information on specified iSCSI session.

- Command Modes**
- EXEC
  - EXEC Privilege

**Supported Modes** All Modes

Command History	Version	Description
	<b>9.9(0.0)</b>	Introduced on the FN IOM.
	<b>9.4(0.0)</b>	Supported on the FN I/O Aggregator.
	<b>8.3.17.0</b>	Supported on the M I/O Aggregator.

## Example

```
Dell# show iscsi sessions detailed
Session 0 :
-----
Target:iqn.2010-11.com.ixia:ixload:iscsi-TG1
Initiator:iqn.2010-11.com.ixia.ixload:initiator-iscsi-2c
Up Time:00:00:01:28 (DD:HH:MM:SS)
Time for aging out:00:00:09:34 (DD:HH:MM:SS)
ISID:806978696102
Initiator Initiator Target Target Connection
IP Address TCP Port IP Address TCPPort ID
10.10.0.44 33345 .10.0.101 3260 0
Session 1 :
-----
Target:iqn.2010-11.com.ixia:ixload:iscsi-TG1
Initiator:iqn.2010-11.com.ixia.ixload:initiator-iscsi-35
Up Time:00:00:01:22 (DD:HH:MM:SS)
Time for aging out:00:00:09:31 (DD:HH:MM:SS)
ISID:806978696102
Initiator Initiator Target Target Connection
IP Address TCP Port IP Address TCPPort ID
10.10.0.53 33432 10.10.0.101 3260 0
```

- Related Commands**
- [show iscsi](#) — displays the currently configured iSCSI settings.
  - [show iscsi sessions](#) — displays information on active iSCSI sessions on the switch that have been established since the last reload.



# Isolated Networks

This chapter describes the isolated networks commands in the Dell Networking OS.

## Topics:

- [io-aggregator isolated-network vlan](#)
- [show io-aggregator isolated-networks](#)

## io-aggregator isolated-network vlan

Enable the isolated-network functionality for a particular VLAN or a set of VLANs.

<b>Syntax</b>	<code>[no] io-aggregator isolated-network vlan <i>vlan-range</i></code>	
<b>Parameters</b>	<b>isolated-network</b>	Specify an isolated network to be configured
	<b>vlan <i>vlan-range</i></b>	Enter the keyword <code>vlan</code> followed by the member VLANs using VLAN IDs (separated by commas), a range of VLAN IDs (separated by a hyphen), a single VLAN ID, or a combination. For example: VLAN IDs (comma-separated): 3, 4, 6. Range (hyphen-separated): 5-10. Combination: 3, 4, 5-10, 8.
<b>Defaults</b>	Not configured.	
<b>Command Modes</b>	CONFIGURATION	
<b>Usage Information</b>	To add more VLANs into an isolated network, you can enter this same command at any later point. The VLANs specified are appended to the existing set of VLANs. To remove a VLAN or a set of VLANs from an isolated network, use the <code>no</code> form of command.	
<b>Supported Modes</b>	All Modes	
<b>Command History</b>	<b>Version</b>	<b>Description</b>
	<b>9.9(0.0)</b>	Introduced on the FN IOM.
	<b>9.5(0.0)</b>	Supported on the FN I/O Aggregator.
	<b>9.5(0.0)</b>	Supported on the M I/O Aggregator.

## Example

```
Dell(conf)#io-aggregator isolated-network vlan 5-10
```

## show io-aggregator isolated-networks

Display the VLANs that are configured to be part of an isolated network on an Aggregator.

<b>Syntax</b>	<code>show io-aggregator isolated-networks</code>	
<b>Parameters</b>	<b>isolated-networks</b>	Specify an isolated network to be configured
	<b>vlan <i>vlan-range</i></b>	Enter the keyword <code>vlan</code> followed by the member VLANs using VLAN IDs (separated by commas), a range of VLAN IDs (separated by a hyphen), a single VLAN ID, or a combination. For example: VLAN IDs (comma-separated): 3, 4, 6. Range (hyphen-separated): 5-10. Combination: 3, 4, 5-10, 8.

**Defaults** None

**Command Modes** EXEC Privilege

**Usage Information** This command is used to show the isolated-network feature status and the VLANs configured for this feature. Show running-config will save this command under io-aggregator.

**Supported Modes** All Modes

**Command History**

<b>Version</b>	<b>Description</b>
<b>9.9(0.0)</b>	Introduced on the FN IOM.
<b>9.5(0.0)</b>	Supported on the FN I/O Aggregator.
<b>9.5(0.0)</b>	Supported on the M I/O Aggregator.

**Example**

```
Dell#show io-aggregator isolated-networks
Isolated Network Enabled VLANs : 5-10
```

# Link Aggregation Control Protocol (LACP)

This chapter contains commands for Dell Networking's implementation of the link aggregation control protocol (LACP) for the creation of dynamic link aggregation groups (LAGs — called *port-channels* in Dell Networking OS parlance).

## Topics:

- `auto-lag enable`
- `clear lacp counters`
- `debug lacp`
- `delay-restore abort-threshold`
- `io-aggregator auto-lag enable`
- `lacp link-fallback`
- `lacp long-timeout`
- `lacp port-priority`
- `port-channel mode`
- `port-channel-protocol lacp`
- `show interfaces port-channel`
- `show io-aggregator auto-lag status`
- `show lacp`
- `show link-bundle-distribution port-channel`
- `show port-channel-flow`

## auto-lag enable

Enable auto-lag on a server facing port.

**Syntax** `auto-lag enable`

To disable the auto-lag use the `no auto-lag enable` command.

When disabled, the server port associated in a LAG is removed and the LAG itself gets removed. Any LACPDU's received on the server port are discarded.

**Defaults** Enabled

**Command Modes** INTERFACE

**Supported Modes** Standalone, Stacking, VLT

Command History	Version	Description
	<b>9.9(0.0)</b>	Introduced on the FN IOM.
	<b>9.6(0.0)</b>	Supported on the FN I/O Aggregator
	<b>9.6(0.0)</b>	Supported on the M I/O Aggregator.

## clear lacp counters

Clear Port Channel counters.

**Syntax** `clear lacp port-channel-number counters`

<b>Parameters</b>	<b><i>port-channel-number</i></b>	Enter a port-channel number: The range is from 1 to 128.
<b>Command Modes</b>	EXEC EXEC Privilege	
<b>Supported Modes</b>	All Modes	
<b>Command History</b>	<b>Version</b>	<b>Description</b>
	<b>9.9(0.0)</b>	Introduced on the FN IOM.
	<b>9.4(0.0)</b>	Supported on the FN I/O Aggregator.
	<b>8.3.17.0</b>	Supported on the M I/O Aggregator.
<b>Related Commands</b>	<a href="#">show lacp</a> — displays the LACP configuration.	

## debug lacp

Debug LACP (events).

<b>Syntax</b>	<code>debug lacp [events   pdu interface [in   out]]</code> To disable LACP debugging, use the <code>no debug lacp [events   pdu interface [in   out]]</code> command.	
<b>Parameters</b>	<b>events</b>	(OPTIONAL) Enter the keyword <code>events</code> to debug the LACP event information.
	<b>pdu in   out</b>	(OPTIONAL) Enter the keyword <code>pdu</code> to debug the LACP Protocol Data Unit information. Optionally, enter an <code>in</code> or <code>out</code> parameter to: <ul style="list-style-type: none"> <li>• Receive <code>enterin</code></li> <li>• Transmit <code>enterout</code></li> </ul>
	<b>interface in   out</b>	Enter the following keywords and slot/port or number information: <ul style="list-style-type: none"> <li>• For a Ten-Gigabit Ethernet interface, enter the keyword <code>TenGigabitEthernet</code> followed by the slot/port information.</li> </ul>
<b>Defaults</b>	none	
<b>Command Modes</b>	EXEC EXEC Privilege	
<b>Supported Modes</b>	All Modes	
<b>Command History</b>	<b>Version</b>	<b>Description</b>
	<b>8.3.17.0</b>	Supported on the M I/O Aggregator.

## delay-restore abort-threshold

Increase the Boot Up timer to some value (>60 seconds).

<b>Syntax</b>	<code>delay-restore abort-threshold &lt;interval&gt;</code> To remove use the <code>no delay-restore abort-threshold</code> command.
<b>Defaults</b>	60 seconds

**Command Modes** VLT DOMAIN

**Command History** This guide is platform-specific. For command information about other platforms, refer to the relevant *Dell Networking OS Command Line Reference Guide*.

The following is a list of the Dell Networking OS version history for this command.

Version	Description
9.8(0.0)	Introduced on the S3048-ON and S4048-ON.
9.7(0.0)	Introduced on the S4820T, S4810, S6000, S5000, Z9000, S6000-ON and Z9500.

**Parameter** Enter the value (in seconds) to specify the time interval for delay restore timer to abort. This timer is applicable only during reload/boot-up and not in other scenarios (example, ICL flap).

The range is from 1 to 1800 seconds.

**Usage Information** To abort VLT delay restore timer as the maximum threshold, the maximum time interval is applied to hold down ICL peer-up in the start-up configurations during the reload.

## io-aggregator auto-lag enable

Enable auto-lag globally on the server facing ports

**Syntax** `io-aggregator auto-lag enable`

To disable the auto-lag, use the `no io-aggregator auto-lag enable` command.

When disabled, all the server ports associated in a LAG are removed and the LAG itself gets removed. Any LACPDU received on the server ports are discarded.

**Defaults** Enabled

**Command Modes** CONFIGURATION

**Supported Modes** Standalone, Stacking, VLT

Command History	Version	Description
	9.9(0.0)	Introduced on the FN IOM.
	9.6(0.0)	Supported on the FN I/O Aggregator.
	9.6(0.0)	Supported on the M I/O Aggregator.

**Related Commands** [show io-aggregator auto-lag status](#)—displays global information on the auto-lag status.

## lACP link-fallback

Enable the LACP link-fallback feature.

**Syntax** `lACP link-fallback member-independent port-channel 128`

To disable the LACP link-fallback, use the `no lACP link-fallback member-independent port-channel 128` command.

**Command Modes** INTERFACE  
CONFIGURATION

**Supported Modes** Standalone, Stacking, and VLT

**Command History** This guide is platform-specific. For command information about other platforms, refer to the relevant *Dell Networking OS Command Reference Guide*.

The following is a list of the Dell Networking OS version history for this command.

Version	Description
9.11(0.0)	Introduced the support on VLT mode.
9.9(0.0)	Introduced on the FN IOM.
9.7(0.0)	Introduced on the M I/O Aggregator and FN I/O Aggregator.

## lacp long-timeout

Configure a long timeout period (30 seconds) for an LACP session.

<b>Syntax</b>	<code>lacp long-timeout</code> To reset the timeout period to a short timeout (1 second), use the <code>no lacp long-timeout</code> command.										
<b>Defaults</b>	<b>1 second</b>										
<b>Command Modes</b>	INTERFACE (conf-if-po-number)										
<b>Supported Modes</b>	Programmable-Mux (PMUX)										
<b>Command History</b>	<table><thead><tr><th>Version</th><th>Description</th></tr></thead><tbody><tr><td>9.9(0.0)</td><td>Introduced on the FN IOM.</td></tr><tr><td>9.4(0.0)</td><td>Supported on the FN I/O Aggregator.</td></tr><tr><td>9.2(0.0)</td><td>Introduced on the M I/O Aggregator.</td></tr><tr><td>8.3.16.1</td><td>Introduced on the MXL 10/40GbE Switch IO Module.</td></tr></tbody></table>	Version	Description	9.9(0.0)	Introduced on the FN IOM.	9.4(0.0)	Supported on the FN I/O Aggregator.	9.2(0.0)	Introduced on the M I/O Aggregator.	8.3.16.1	Introduced on the MXL 10/40GbE Switch IO Module.
Version	Description										
9.9(0.0)	Introduced on the FN IOM.										
9.4(0.0)	Supported on the FN I/O Aggregator.										
9.2(0.0)	Introduced on the M I/O Aggregator.										
8.3.16.1	Introduced on the MXL 10/40GbE Switch IO Module.										
<b>Usage Information</b>	This command applies to dynamic port-channel interfaces only. When applied on a static port-channel, this command has no effect.										

## lacp port-priority



To influence which ports will be put in Standby mode when there is a hardware limitation that prevents all compatible ports from aggregating, configure the port priority.

<b>Syntax</b>	<code>lacp port-priority <i>priority-value</i></code> To return to the default setting, use the <code>no lacp port-priority <i>priority-value</i></code> command.										
<b>Parameters</b>	<b><i>priority-value</i></b> Enter the port-priority value. The higher the value number, the lower the priority. The range is from 1 to 65535. The default is <b>32768</b> .										
<b>Defaults</b>	<b>32768</b>										
<b>Command Modes</b>	INTERFACE										
<b>Supported Modes</b>	Programmable-Mux (PMUX)										
<b>Command History</b>	<table><thead><tr><th>Version</th><th>Description</th></tr></thead><tbody><tr><td>9.9(0.0)</td><td>Introduced on the FN IOM.</td></tr><tr><td>9.4(0.0)</td><td>Supported on the FN I/O Aggregator.</td></tr><tr><td>9.2(0.0)</td><td>Introduced on the M I/O Aggregator.</td></tr><tr><td>8.3.16.1</td><td>Introduced on the MXL 10/40GbE Switch IO Module.</td></tr></tbody></table>	Version	Description	9.9(0.0)	Introduced on the FN IOM.	9.4(0.0)	Supported on the FN I/O Aggregator.	9.2(0.0)	Introduced on the M I/O Aggregator.	8.3.16.1	Introduced on the MXL 10/40GbE Switch IO Module.
Version	Description										
9.9(0.0)	Introduced on the FN IOM.										
9.4(0.0)	Supported on the FN I/O Aggregator.										
9.2(0.0)	Introduced on the M I/O Aggregator.										
8.3.16.1	Introduced on the MXL 10/40GbE Switch IO Module.										

# port-channel mode

Configure the LACP port channel mode.

**Syntax** `port-channel number mode [active] [passive] [off]`

<b>Parameters</b>	<b>number</b>	Enter the keywords <code>number</code> then a number.
	<b>active</b>	Enter the keyword <code>active</code> to set the mode to the active state.  <b>NOTE:</b> LACP modes are defined in <i>Usage Information</i> .
	<b>passive</b>	Enter the keyword <code>passive</code> to set the mode to the passive state.  <b>NOTE:</b> LACP modes are defined in <i>Usage Information</i> .
	<b>off</b>	Enter the keyword <code>off</code> to set the mode to the off state.  <b>NOTE:</b> LACP modes are defined in <i>Usage Information</i> .

**Defaults** `off`

**Command Modes** INTERFACE

**Supported Modes** Programmable-Mux (PMUX)

<b>Command History</b>	<b>Version</b>	<b>Description</b>
	<b>9.9(0.0)</b>	Introduced on the FN IOM.
	<b>9.4(0.0)</b>	Supported on the FN I/O Aggregator.
	<b>9.2(0.0)</b>	Introduced on the M I/O Aggregator.
	<b>8.3.16.1</b>	Introduced on the MXL 10/40GbE Switch IO Module.

**Usage Information** LACP Modes

<b>Mode</b>	<b>Function</b>
<b>active</b>	An interface is in an active negotiating state in this mode. LACP runs on any link configured in the active state and also automatically initiates negotiation with other ports by initiating LACP packets.
<b>passive</b>	An interface is not in an active negotiating state in this mode. LACP runs on any link configured in the passive state. Ports in a passive state respond to negotiation requests from other ports that are in active states. Ports in a passive state respond to LACP packets
<b>off</b>	An interface cannot be part of a dynamic port channel in off mode. LACP does not run on a port configured in off mode.

# port-channel-protocol lacp

Enable LACP on any LAN port.

**Syntax** `port-channel-protocol lacp`  
To disable LACP on a LAN port, use the `no port-channel-protocol lacp` command.

**Command Modes** INTERFACE

**Supported Modes** Programmable-Mux (PMUX)

<b>Command History</b>	<b>Version</b>	<b>Description</b>
	<b>9.2(0.0)</b>	Introduced on the M I/O Aggregator.

Version	Description
8.3.16.1	Introduced on the MXL 10/40GbE Switch IO Module.

### Example

```
Dell(conf)#interface TenGigabitEthernet 3/15
Dell(conf-if-tengig-3/15)#no shutdown
Dell(conf-if-tengig-3/15)#port-channel-protocol lacp
Dell(conf-if-tengig-3/15-lacp)#port-channel 32 mode active
...
Dell(conf)#interface TenGigabitEthernet 3/16
Dell(conf-if-tengig-3/16)#no shutdown
Dell(conf-if-tengig-3/16)#port-channel-protocol lacp
Dell(conf-if-tengig-3/16-lacp)#port-channel 32 mode active
```

## show interfaces port-channel

Display information on configured Port Channel groups.

**Syntax** `show interfaces port-channel [channel-number] [brief|description]`

### Parameters

<b>channel-number</b>	For a Port Channel interface, enter the keyword <code>port-channel</code> followed by a number. The range is from 1 to 128.
<b>brief</b>	(OPTIONAL) Enter the keyword <code>brief</code> to display only the port channel number, the state of the port channel, and the number of interfaces in the port channel.
<b>description</b>	(OPTIONAL) Enter the keyword <code>description</code> to display interface information with description.

**NOTE:** This command also enables you to view information corresponding to a range of ports.

- For port-channel interfaces, you can specify multiple ports as `port-range`. For example, if you want to display information corresponding to all ports between 1 and 4, specify the port range as `show interfaces port-channel 1 - 4`.

**Command Modes**

- EXEC
- EXEC Privilege

**Supported Modes** All Modes

### Command History

Version	Description
9.9(0.0)	Introduced on the FN IOM and added support to display the interface configurations corresponding to a range of ports.
9.7(0.0)	Introduced on the M I/O Aggregator.
9.4(0.0)	Supported on the FN I/O Aggregator.

**Usage Information** The following describes the `show interfaces port-channel` command shown in the following example.

Field	Description
<b>Port-Channel 1...</b>	Displays the status of LAG. In the Example, the status of the LAG, LAG fate-sharing group ("Failover-group") is listed.
<b>Hardware is...</b>	Displays the interface's hardware information and its assigned MAC address.
<b>Port-channel is part...</b>	Indicates whether the LAG is part of a LAG fate-sharing group ("Failover-group").
<b>Internet address...</b>	States whether an IP address is assigned to the interface. If an IP address is assigned, that address is displayed.
<b>MTU 1554...</b>	Displays link and IP MTU.



Field	Description
<b>LineSpeed</b>	Displays the interface's line speed. For a port channel interface, it is the line speed of the interfaces in the port channel.
<b>Members in this...</b>	Displays the interfaces belonging to this port channel.
<b>ARP type:...</b>	Displays the ARP type and the ARP timeout value for the interface.
<b>Last clearing...</b>	Displays the time when the <code>show interfaces</code> counters were cleared.
<b>Queueing strategy.</b>	States the packet queuing strategy. FIFO means first in first out.
<b>packets input...</b>	Displays the number of packets and bytes into the interface.
<b>Input 0 IP packets...</b>	Displays the number of packets with IP headers, VLAN tagged headers, and MPLS headers. The number of packets may not add correctly because a VLAN tagged IP packet counts as both a VLAN packet and an IP packet.
<b>0 64-byte...</b>	Displays the size of packets and the number of those packets entering that interface. This information is displayed over two lines.
<b>Received 0...</b>	Displays the type and number of errors or other specific packets received. This information is displayed over three lines.
<b>Output 0...</b>	Displays the type and number of packets sent out the interface. This information is displayed over three lines.
<b>Rate information...</b>	Displays the traffic rate information into and out of the interface. Traffic rate is displayed in bits and packets per second.
<b>Time since...</b>	Displays the time since the last change in the configuration of this interface.

### Example (EtherScale)

```
Dell#show interfaces port-channel
Port-channel 1 is down, line protocol is down
Hardware address is 00:1e:c9:f1:00:05, Current address is
00:1e:c9:f1:00:05
Interface index is 1107755009
Minimum number of links to bring Port-channel up is 1
Internet address is not set
Mode of IP Address Assignment : NONE
DHCP Client-ID :lag1001ec9f10005
MTU 12000 bytes, IP MTU 1500 bytes
LineSpeed auto
Members in this channel:
ARP type: ARPA, ARP Timeout 04:00:00
Last clearing of "show interface" counters 03:28:00
Queueing strategy: fifo
Input Statistics:
0 packets, 0 bytes
0 64-byte pkts, 0 over 64-byte pkts, 0 over 127-byte pkts
0 over 255-byte pkts, 0 over 511-byte pkts, 0 over 1023-byte pkts
0 Multicasts, 0 Broadcasts
0 runts, 0 giants, 0 throttles
0 CRC, 0 overrun, 0 discarded
Output Statistics:
0 packets, 0 bytes, 0 underruns
0 64-byte pkts, 0 over 64-byte pkts, 0 over 127-byte pkts
0 over 255-byte pkts, 0 over 511-byte pkts, 0 over 1023-byte pkts
0 Multicasts, 0 Broadcasts, 0 Unicasts
0 throttles, 0 discarded, 0 collisions
```

**User Information** The following describes the `show interfaces port-channel brief` command shown in the following example.

Field	Description
<b>LAG</b>	Lists the port channel number.

Field	Description
<b>Mode</b>	Lists the mode: <ul style="list-style-type: none"> <li>• L3 — for Layer 3</li> <li>• L2 — for Layer 2</li> </ul>
<b>Status</b>	Displays the status of the port channel. <ul style="list-style-type: none"> <li>• down — if the port channel is disabled (<code>shutdown</code>)</li> <li>• up — if the port channel is enabled (<code>no shutdown</code>)</li> </ul>
<b>Uptime</b>	Displays the age of the port channel in hours:minutes:seconds.
<b>Ports</b>	Lists the interfaces assigned to this port channel.
<b>(untitled)</b>	Displays the status of the physical interfaces (up or down). <ul style="list-style-type: none"> <li>• In Layer 2 port channels, an * (asterisk) indicates which interface is the primary port of the port channel. The primary port sends out interface PDU.</li> <li>• In Layer 3 port channels, the primary port is not indicated.</li> </ul>

### Example

```
Dell#show int po bri
Codes: L - LACP Port-channel
       O - OpenFlow Controller Port-channel
       A - Auto Port-channel
       I - Internally Lagged
LAG Mode Status Uptime Ports
L   128 L3 down 00:00:00
Dell#
```

To indicate the LACP fallback, `Internally lagged` is added to the list. When the LAG auto-configures itself, the LAG status describes as 'I'.

### Related Commands

[show lacp](#) — displays the LACP matrix.

## show io-aggregator auto-lag status

Displays global information on the auto-lag status.

**Syntax** `show io-aggregator auto-lag status`

**Command Modes** EXEC

**Supported Modes** Standalone, Stacking, VLT

### Command History

Version	Description
<b>9.9(0.0)</b>	Introduced on the FN IOM.
<b>9.6(0.0)</b>	Supported on the FN I/O Aggregator.
<b>9.6(0.0)</b>	Supported on the M I/O Aggregator.

### Example

```
Dell-ct-mx1-1-b1(conf)#do show io-aggregator auto-lag status
Auto LAG creation on server port(s) is disabled
```

## show lacp

Displays the LACP matrix.

**Syntax** `show lacp port-channel-number [sys-id | counters]`

## Parameters

<b>port-channel-number</b>	Enter a port-channel number: The range is from 1 to 128.
<b>sys-id</b>	(OPTIONAL) Enter the keywords <code>sys-id</code> and the value that identifies a system.
<b>counters</b>	(OPTIONAL) Enter the keyword <code>counters</code> to display the LACP counters.

- Command Modes**
- EXEC
  - EXEC Privilege

**Supported Modes** All Modes

## Command History

Version	Description
<b>9.9(0.0)</b>	Introduced on the FN IOM.
<b>9.4(0.0)</b>	Supported on the FN I/O Aggregator.
<b>8.3.17.0</b>	Supported on the M I/O Aggregator.

## Example (Port-Channel-Number)

```
Dell#show lacp 128
Port-channel 1 admin up, oper up, mode lacp
Actor System ID:Priority 32768, Address 0001.e800.a12b
Partner System ID:Priority 32768, Address 0001.e801.45a5
Actor Admin Key 1, Oper Key 1, Partner Oper Key 1
LACP LAG 1 is an aggregatable link

A-Active LACP, B-Passive LACP, C-Short Timeout, D-Long Timeout
E-Aggregatable Link, F-Individual Link, G-IN_SYNC, H-OUT_OF_SYNC
I-Collection enabled, J-Collection disabled, K-Distribution enabled L-
Distribution disabled,
M-Partner Defaulted, N-Partner Non-defaulted, O-Receiver is in expired
state,
P-Receiver is not in expired state

Port Te 0/1 is enabled, LACP is enabled and mode is lacp
Actor Admin: State ACEHJLMP Key 1 Priority 128
Oper: State ACEGIKNP Key 1 Priority 128
Partner Admin: State BDFHJLMP Key 0 Priority 0
Oper: State BCEGIKNP Key 1 Priority 128
Dell#
```

## Example (Sys-id)

```
Dell#show lacp 1 sys-id
Actor System ID: Priority 32768, Address 0001.e800.a12b
Partner System ID: Priority 32768, Address 0001.e801.45a5
Dell#
```

## Example (Counter)

```
Dell#show lacp 1 counters
-----
Port          LACP PDU   Marker PDU   Unknown   Illegal
              Xmit  Recv      Xmit Recv    Pkts Rx    Pkts Rx
-----
TenGig 0/1    200   200        0    0         0         0
Dell#
```

## Related Commands

- [clear lacp counters](#) — Clears the LACP counters.
- [show interfaces port-channel](#) — Displays the information on configured Port Channel groups.

# show link-bundle-distribution port-channel

Display the traffic-handling and utilization of the member interfaces of the port channel.

**Syntax** `show link-bundle-distribution port-channel`

**Command Modes** EXEC  
EXEC Privilege

**Supported Modes** All Modes

Command History	Version	Description
	9.3.0.0	Introduced on the M I/O Aggregator

**Usage Information** The following table describes the output fields of this show command:

**Table 2. Output Fields**

Field	Description
Link-bundle trigger threshold	Threshold value that is the checkpoint, exceeding which the link bundle is marked as being overutilized and alarm is generated
LAG bundle number	Number of the LAG bundle
Utilization (In Percent)	Traffic usage in percentage of the packets processed by the port channel
Alarm State	Indicates whether an alarm is generated if overutilization of the port channel occurred. Possible values are Active and Inactive
Interface	Slot and port number, and the type of the member interface of the port channel
Line Protocol	Indicates whether the interface is administratively up or down
Utilization (In Percent)	Traffic usage in percentage of the packets processed by the particular member interface

## Example

```
Dell#show link-bundle-distribution port-channel
Link-bundle trigger threshold - 60

LAG bundle - 1      Utilization[In Percent] - 0      Alarm State -
Inactive

Interface          Line Protocol  Utilization[In Percent]
Te 0/5             Up            0
Te 0/13            Up            0
```

# show port-channel-flow

Display an egress port in a given port-channel flow.

**Syntax** `show port-channel-flow port-channel number incoming-interface interface { src-mac address dest-mac address {vlan vlanid | ether-type }} [ src-ip address dest-ip address ] [ src-port number dest-port number ]`

**Parameters** **port-channel number** Enter the keywords port-channel then the number of the port channel to display flow information. The range is from 1 to 128.

<b>incoming-interface interface</b>	Enter the keywords <code>incoming-interface</code> then the interface type and slot/port or number information: <ul style="list-style-type: none"> <li>For a 10-Gigabit Ethernet interface, enter the keyword <code>TenGigabitEthernet</code> then the slot/port information.</li> </ul>
<b>src-mac address</b>	Enter the keywords <code>src-mac</code> then the MAC source address in the <code>nn:nn:nn:nn:nn:nn</code> format.
<b>dest-mac address</b>	Enter the keywords <code>dest-mac</code> then the MAC destination address in the <code>nn:nn:nn:nn:nn:nn</code> format.
<b>vlan vlan-id</b>	Enter the keyword <code>vlan</code> then the VLAN ID. The range is from 1 to 4094.
<b>ether-type</b>	Enter the keywords <code>ether-type</code> then the ether-value in the <code>XX:XX</code> format.
<b>src-ip address</b>	Enter the keywords <code>src-ip</code> then the IP source address in IP address format.
<b>dest-ip address</b>	Enter the keywords <code>dest-ip</code> then the IP destination address in IP address format.
<b>src-port number</b>	Enter the keywords <code>src-port</code> then the source port number. The range is from 1 to 65536. The default is <b>None</b> .
<b>dest-port number</b>	Enter the keywords <code>dest-port</code> then the destination port number. The range is from 1 to 65536. The default is <b>None</b> .

**Command Modes** EXEC

**Supported Modes** All Modes

**Command History**

Version	Description
<b>9.9(0.0)</b>	Introduced on the FN IOM.
<b>9.4(0.0)</b>	Supported on the FN I/O Aggregator.
<b>8.3.17.0</b>	Supported on the M I/O Aggregator.

**Usage Information**

Because this command calculates based on a Layer 2 hash algorithm, use this command to display flows for switched Layer 2 packets, not for routed packets (use the `show ip flow` command to display routed packets).

The `show port-channel-flow` command returns the egress port identification in a given port-channel if a valid flow is entered. A mismatched flow error occurs if MAC-based hashing is configured for a Layer 2 interface and you are trying to display a Layer 3 flow.

The output displays three entries:

- Egress port for unfragmented packets.
- In the event of fragmented packets, the egress port of the first fragment.
- In the event of fragmented packets, the egress port of the subsequent fragments.

 **NOTE:** In the `show port-channel-flow` command output, the egress port for an unknown unicast, multicast, or broadcast traffic is not displayed.

## Layer 2

This chapter describes commands to configure Layer 2 features.

This chapter contains the following sections:

- [MAC Addressing Commands](#)
- [Virtual LAN \(VLAN\) Commands](#)

### Topics:

- [MAC Addressing Commands](#)
- [Virtual LAN \(VLAN\) Commands](#)
- `clear mac-address-table dynamic`
- `description`
- `mac-address-table aging-time`
- `mac-address-table static`
- `mac-address-table station-move refresh-arp`
- `show cam mac stack-unit`
- `show mac-address-table`

## MAC Addressing Commands

The following commands are related to configuring, managing, and viewing MAC addresses:

- `clear mac-address-table dynamic`
- `mac-address-table aging-time`
- `mac-address-table static`
- `mac-address-table station-move refresh-arp`
- `show cam mac stack-unit`
- `show mac-address-table`

## Virtual LAN (VLAN) Commands

The following commands configure and monitor virtual local area networks (VLANs). VLANs are a virtual interface and use many of the same commands as physical interfaces.

You can configure an IP address and Layer 3 protocols on a VLAN called Inter-VLAN routing. FTP, TFTP, ACLs and SNMP are not supported on a VLAN.

## clear mac-address-table dynamic

Clear the MAC address table of all MAC addresses learned dynamically.

### Syntax

```
clear mac-address-table dynamic {address mac-address | all | interface
interface | vlan vlan-id}
```

### Parameters

<b>address <i>mac-address</i></b>	Enter the keyword <code>address</code> followed by a MAC address in <code>nn:nn:nn:nn:nn:nn</code> format.
<b>all</b>	Enter the keyword <code>all</code> to delete all MAC address entries in the MAC address table.
<b>interface <i>interface</i></b>	Enter the following keywords and slot/port or number information:

- For a 10-Gigabit Ethernet interface, enter the keyword `TenGigabitEthernet` followed by the slot/port information.

**vlan *vlan-id*** Enter the keyword `vlan` followed by a VLAN ID number from 1 to 4094.

**Command Modes** EXEC Privilege

**Supported Modes** All Modes

Command History	Version	Description
	<b>9.9(0.0)</b>	Introduced on the FN IOM.
	<b>9.4(0.0)</b>	Supported on the FN I/O Aggregator.
	<b>8.3.17.0</b>	Supported on the M I/O Aggregator.

## description

Add a description about the selected VLAN.

**Syntax** `description description`  
 To remove the description from the VLAN, use the `no description` command.

**Parameters** *description* Enter a text string description to identify the VLAN (80 characters maximum).

**Defaults** none

**Command Modes** INTERFACE VLAN

**Supported Modes** All Modes

Command History	Version	Description
	<b>9.9(0.0)</b>	Introduced on the FN IOM.
	<b>9.4(0.0)</b>	Supported on the FN I/O Aggregator.
	<b>8.3.17.0</b>	Supported on the M I/O Aggregator.

**Related Commands** [show vlan](#) – displays the VLAN configuration.

## mac-address-table aging-time

Specify an aging time for MAC addresses to remove from the MAC address table.

**Syntax** `mac-address-table aging-time seconds`  
 To delete the configured aging time, use the `no mac-address-table aging-time seconds` command.

**Parameters** *seconds* Enter either zero (0) or a number as the number of seconds before MAC addresses are relearned. To disable aging of the MAC address table, enter 0. The range is from 10 to 1000000. The default is **1800 seconds**.

**Defaults** **1800 seconds**

**Command Modes** CONFIGURATION

**Supported Modes** Programmable-Mux (PMUX)

Command History	Version	Description
	<b>9.9(0.0)</b>	Introduced on the FN IOM.
	<b>9.4(0.0)</b>	Supported on the FN I/O Aggregator.
	<b>9.2(0.0)</b>	Introduced on the M I/O Aggregator.

## mac-address-table static

Associate specific MAC or hardware addresses to an interface and virtual local area networks (VLANs).

**Syntax** `mac-address-table static mac-address output interface vlan vlan-id`  
 To remove a MAC address, use the `no mac-address-table static mac-address output interface vlan vlan-id` command.

**Parameters**

- mac-address** Enter the 48-bit hexadecimal address in nn:nn:nn:nn:nn:nn format.
- output interface** Enter the keyword `output` then one of the following interfaces for which traffic is forwarded:
  - For a Port Channel interface, enter the keywords `port-channel` then a number. The range is from 1 to 128.
  - For a 10-Gigabit Ethernet interface, enter the keyword `TenGigabitEthernet` then the slot/port information.
  - For a 40-Gigabit Ethernet interface, enter the keyword `fortyGigE` then the slot/port information.
- vlan vlan-id** Enter the keyword `vlan` then a VLAN ID number from 1 to 4094.

**Defaults** Not configured.

**Command Modes** CONFIGURATION

**Supported Modes** Programmable-Mux (PMUX)

Command History	Version	Description
	<b>9.2(0.0)</b>	Introduced on the M I/O Aggregator.
	<b>8.3.16.1</b>	Introduced on the MXL 10/40GbE Switch IO Module.

## mac-address-table station-move refresh-arp

Ensure that address resolution protocol (ARP) refreshes the egress interface when a station move occurs due to a topology change.

**Syntax** `[no] mac-address-table station-move refresh-arp`

**Defaults** Enabled

**Command Modes** CONFIGURATION

**Supported Modes** Programmable-Mux (PMUX)

Command History	Version	Description
	<b>9.9(0.0)</b>	Modified the default option from none to Enabled. Introduced on the FN IOM.
	<b>9.4(0.0)</b>	Supported on the FN I/O Aggregator.
	<b>9.2(0.0)</b>	Introduced on the M I/O Aggregator.
	<b>8.3.16.1</b>	Introduced on the MXL 10/40GbE Switch IO Module.



**Usage Information**

For details about using this command, refer to the “NIC Teaming” section of the Layer 2 chapter in the *Dell Networking OS Configuration Guide*.

## show cam mac stack-unit

Display the content addressable memory (CAM) size and the portions allocated for MAC addresses and for MAC ACLs.

**Syntax** `show cam mac stack-unit unit_number port-set port-pipe count [vlan vlan-id] [interface interface]`

<b>Parameters</b>	<b>stack-unit</b> <i>unit_number</i>	(REQUIRED) Enter the keyword <code>stack-unit</code> followed by a stack member number to select the stack unit for which to gather information. The range is 0 to 5.
	<b>port-set</b> <i>port-pipe</i>	(REQUIRED) Enter the keywords <code>port-set</code> followed by a Port-Pipe number to select the Port-Pipe for which to gather information. The range is 0.
	<b>address</b> <i>mac-addr</i>	(OPTIONAL) Enter the keyword <code>address</code> followed by a MAC address in the <code>nn:nn:nn:nn:nn:nn</code> format to display information on that MAC address.
	<b>dynamic</b>	(OPTIONAL) Enter the keyword <code>dynamic</code> to display only those MAC addresses learned dynamically by the switch.
	<b>static</b>	(OPTIONAL) Enter the keyword <code>static</code> to display only those MAC address specifically configured on the switch.
	<b>interface</b> <i>interface</i>	(OPTIONAL) Enter the keyword <code>interface</code> followed by the interface type, slot and port information: <ul style="list-style-type: none"> <li>• For a 10-Gigabit Ethernet interface, enter the keyword <code>TenGigabitEthernet</code> followed by the slot/port information.</li> </ul>
<b>vlan</b> <i>vlan-id</i>	(OPTIONAL) Enter the keyword <code>vlan</code> followed by the VLAN ID to display the MAC address assigned to the VLAN. The range is from 1 to 4094.	

- Command Modes**
- EXEC
  - EXEC Privilege

**Supported Modes** All Modes

<b>Command History</b>	<b>Version</b>	<b>Description</b>
	<b>9.9(0.0)</b>	Introduced on the FN IOM.
	<b>9.4(0.0)</b>	Supported on the FN I/O Aggregator.
	<b>8.3.17.0</b>	Supported on the M I/O Aggregator.

## show mac-address-table

Display the MAC address table.

**Syntax** `show mac-address-table [dynamic | static] [address mac-address | interface interface | vlan vlan-id] [count [vlan vlan-id] [interface interface-type [slot [/port]]]]`

<b>Parameters</b>	<b>dynamic</b>	(OPTIONAL) Enter the keyword <code>dynamic</code> to display only those MAC addresses the switch dynamically learns. Optionally, you can also add one of these combinations: <code>address/mac-address</code> , <code>interface/interface</code> , or <code>vlan vlan-id</code> .
	<b>static</b>	(OPTIONAL) Enter the keyword <code>static</code> to display only those MAC addresses specifically configured on the switch. Optionally, you can also add one of these combinations: <code>address/mac-address</code> , <code>interface/interface</code> , or <code>vlan vlan-id</code> .

<b>address mac-address</b>	(OPTIONAL) Enter the keyword <code>address</code> then a MAC address in the <code>nn:nn:nn:nn:nn:nn</code> format to display information on that MAC address.
<b>interface interface</b>	(OPTIONAL) Enter the keyword <code>interface</code> then the interface type, slot and port information: <ul style="list-style-type: none"> <li>For a Port Channel interface, enter the keywords <code>port-channel</code> then a number. The range is from 1 to 128.</li> <li>For a 10-Gigabit Ethernet interface, enter the keyword <code>TenGigabitEthernet</code> then the slot/port information.</li> </ul>
<b>interface interface-type</b>	(OPTIONAL) Instead of entering the keyword <code>interface</code> then the interface type, slot and port information, as above, you can enter the interface type, then just a slot number.
<b>vlan vlan-id</b>	(OPTIONAL) Enter the keyword <code>vlan</code> then the VLAN ID to display the MAC address assigned to the VLAN. The range is 1 to 4094.
<b>count</b>	(OPTIONAL) Enter the keyword <code>count</code> , then optionally, by an interface or VLAN ID, to display total or interface-specific static addresses, dynamic addresses, and MAC addresses in use.

- Command Modes**
- EXEC
  - EXEC Privilege

**Supported Modes** Programmable-Mux (PMUX)

<b>Command History</b>	<b>Version</b>	<b>Description</b>
	9.9(0.0)	Introduced on the FN IOM.
	9.4(0.0)	Supported on the FN I/O Aggregator.
	9.2(0.0)	Introduced on the M I/O Aggregator.

**Usage Information** The following describes the `show mac-address-table` command shown in the following example.

Column Heading	Description
<b>VlanId</b>	Displays the VLAN ID number.
<b>Mac Address</b>	Displays the MAC address in <code>nn:nn:nn:nn:nn:nn</code> format.
<b>Type</b>	Lists whether the MAC address was manually configured (Static), learned dynamically (Dynamic), or associated with a specific port (Sticky).
<b>Interface</b>	Displays the interface type and slot/port information. The following abbreviations describe the interface types: <ul style="list-style-type: none"> <li>gi — Gigabit Ethernet then a slot/port.</li> <li>po — Port Channel then a number. The range is from 1 to 255 for TeraScale.</li> <li>so — SONET then a slot/port.</li> <li>te — 10 Gigabit Ethernet then a slot/port.</li> </ul>
<b>State</b>	Lists if the MAC address is in use (Active) or not in use (Inactive).

**Example**

```
Dell#show mac-address-table
VlanId Mac Address      Type      Interface  State
20      00:00:c9:ad:f6:12    Dynamic   Te 0/3     Active
Dell#
```

**Usage Information** The following describes the `show mac-address-table` command shown in the following example.

Column Heading	Description
<b>VlanId</b>	Displays the VLAN ID number.

Column Heading	Description
<b>Mac Address</b>	Displays the MAC address in nn:nn:nn:nn:nn:nn format.
<b>Type</b>	Lists whether the MAC address was manually configured (Static), learned (Dynamic), or associated with a specific port (Sticky). An (N) indicates that the specified MAC address has been learnt by a neighbor and is synced to the node.
<b>Interface</b>	Displays the interface type and slot/port information. The following abbreviations describe the interface types: <ul style="list-style-type: none"> <li>• gi — Gigabit Ethernet then a slot/port</li> <li>• po — Port Channel then a number. The range is from 1 to 255. \</li> <li>• so — SONET then a slot/port.</li> <li>• te — 10-Gigabit Ethernet then a slot/port.</li> </ul>
<b>State</b>	Lists if the MAC address is in use (Active) or not in use (Inactive).

The following describes the `show mac-address-table count` command shown in the following example.

Line Beginning With	Description
<b>MAC Entries...</b>	Displays the number of MAC entries learned per VLAN.
<b>Dynamic Address...</b>	Lists the number of dynamically learned MAC addresses.
<b>Static Address...</b>	Lists the number of user-defined MAC addresses.
<b>Total MAC...</b>	Lists the total number of MAC addresses the switch uses.

#### Example (Count)

```
Dell#show mac-address-table count
MAC Entries for all vlans :
Dynamic Address Count :      5
Static Address (User-defined) Count : 0
Total MAC Addresses in Use:  5
Dell#
```

# Link Layer Discovery Protocol (LLDP)

The link layer discovery protocol (LLDP) advertises connectivity and management from the local station to the adjacent stations on an IEEE 802 LAN. LLDP facilitates multi-vendor interoperability by using standard management tools to discover and make available a physical topology for network management. The Dell Networking OS implementation of LLDP is based on IEEE standard 801.1ab.

This chapter describes the LLDP commands.

The starting point for using LLDP is invoking LLDP with the `protocol lldp` command in either CONFIGURATION or INTERFACE mode.

The information LLDP distributes is stored by its recipients in a standard management information base (MIB). You can access the information by a network management system through a management protocol such as simple network management protocol (SNMP).

For details about implementing LLDP/LLDP-MED, refer to the Link Layer Discovery Protocol chapter of the *Dell PowerEdge FN I/O Aggregator Configuration Guide*.

## Topics:

- [advertise dot3-tlv](#)
- [advertise management-tlv](#)
- [advertise interface-port-desc](#)
- [clear lldp counters](#)
- [clear lldp neighbors](#)
- [debug lldp interface](#)
- [disable](#)
- [hello](#)
- [multiplier](#)
- [protocol lldp \(Configuration\)](#)
- [protocol lldp \(Interface\)](#)
- [show lldp neighbors](#)
- [show lldp statistics](#)

## advertise dot3-tlv

Advertise dot3 TLVs (Type, Length, Value).

<b>Syntax</b>	<code>advertise dot3-tlv {max-frame-size}</code>	
	To remove advertised dot3-tlv, use the <code>no advertise dot3-tlv {max-frame-size}</code> command.	
<b>Parameters</b>	<b>max-frame-size</b>	Enter the keywords <code>max-frame-size</code> to advertise the dot3 maximum frame size.
<b>Defaults</b>	none	
<b>Command Modes</b>	CONFIGURATION ( <code>conf-lldp</code> ) and INTERFACE ( <code>conf-if-interface-lldp</code> )	
<b>Supported Modes</b>	Programmable-Mux (PMUX)	
<b>Command History</b>	<b>Version</b>	<b>Description</b>
	<b>9.9(0.0)</b>	Introduced on the FN IOM.
	<b>9.4(0.0)</b>	Supported on the FN I/O Aggregator.
	<b>9.2(0.0)</b>	Introduced on the M I/O Aggregator.

Version	Description
8.3.16.1	Introduced on the MXL 10/40GbE Switch IO Module.

## advertise management-tlv

Advertise management TLVs (Type, Length, Value).

**Syntax** `advertise management-tlv {system-capabilities | system-description | system-name}`

To remove advertised management TLVs, use the `no advertise management-tlv {system-capabilities | system-description | system-name}` command.

**Parameters**

- system-capabilities** Enter the keywords `system-capabilities` to advertise the system capabilities TLVs to the LLDP peer.
- system-description** Enter the keywords `system-description` to advertise the system description TLVs to the LLDP peer.
- system-name** Enter the keywords `system-name` to advertise the system name TLVs to the LLDP peer.

**Defaults** none

**Command Modes** CONFIGURATION (conf-ldp)

**Supported Modes** Programmable-Mux (PMUX)

### Command History

Version	Description
9.9(0.0)	Introduced on the FN IOM.
9.4(0.0)	Supported on the FN I/O Aggregator.
8.3.16.1	Introduced on the M I/O Aggregator.
8.3.16.1	Introduced on the MXL 10/40GbE Switch IO Module.

**Usage Information** The command options `system-capabilities`, `system-description`, and `system-name` can be invoked individually or together, in any sequence.

## advertise interface-port-desc

Advertise port descriptor.

**Syntax** `advertise interface-port-desc {description | port-id}`

To remove the advertised port descriptor, use the `no advertise interface-port-desc {description | port-id}` command.

**Parameters**

- description** Enter the keyword `description` then the interface description.
- port-id** Enter the keyword `port-id` then the port-id. The range is from 0 to 7.

**Defaults** None

**Command Modes** CONFIGURATION (conf-ldp)

INTERFACE (conf-if-interface-ldp)

**Command History** This guide is platform-specific. For command information about other platforms, see the relevant *Dell EMC Networking OS Command Line Reference Guide*.

Version	Description
9.11(2.0P1)	Introduced the <code>description</code> and <code>port-id</code> options.

**Usage Information**

If you do not specify the option, by default the `port-id` takes higher precedence and sends the `port-id` in the LLDP packets.

## clear lldp counters

Clear LLDP transmitting and receiving counters for all physical interfaces or a specific physical interface.

**Syntax** `clear lldp counters interface`

**Parameters** *interface*

Enter the following keywords and slot/port or number information:

- For a 10-Gigabit Ethernet interface, enter the keyword `tenGigabitEthernet` followed by the slot/port information.

**Defaults** none

**Command Modes** EXEC Privilege

**Supported Modes** All Modes

Command History	Version	Description
	8.3.17.0	Supported on the M I/O Aggregator.

## clear lldp neighbors

Clear LLDP neighbor information for all interfaces or a specific interface.

**Syntax** `clear lldp neighbors {interface}`

**Parameters** *interface*

Enter the following keywords and slot/port or number information:

- For a 10-Gigabit Ethernet interface, enter the keyword `tenGigabitEthernet` then the slot/port information.
- For a 40-Gigabit Ethernet interface, enter the keyword `fortyGigE` then the slot/port information.

**Defaults** none

**Command Modes** EXEC Privilege

**Supported Modes** Programmable-Mux (PMUX)

Command History	Version	Description
	9.2(0.0)	Introduced on the M I/O Aggregator.
	8.3.16.1	Introduced on the MXL 10/40GbE Switch IO Module.

## debug lldp interface

Enable LLDP debugging to display timer events, neighbor additions or deletions, and other information about incoming and outgoing packets.

**Syntax** `debug lldp interface {interface | all}{events | packet {brief | detail} {tx | rx | both}}`

To disable debugging, use the `no debug lldp interface {interface | all}{events} {packet {brief | detail} {tx | rx | both}}` command.

<b>Parameters</b>	<b><i>interface</i></b>	Enter the following keywords and slot/port or number information: <ul style="list-style-type: none"><li>For a 10-Gigabit Ethernet interface, enter the keyword <code>tenGigabitEthernet</code> followed by the slot/port information.</li></ul>
	<b>all</b>	(OPTIONAL) Enter the keyword <code>all</code> to display information on all interfaces.
	<b>events</b>	(OPTIONAL) Enter the keyword <code>events</code> to display major events such as timer events.
	<b>packet</b>	(OPTIONAL) Enter the keyword <code>packet</code> to display information regarding packets coming in or going out.
	<b>brief</b>	(OPTIONAL) Enter the keyword <code>brief</code> to display brief packet information.
	<b>detail</b>	(OPTIONAL) Enter the keyword <code>detail</code> to display detailed packet information.
	<b>tx</b>	(OPTIONAL) Enter the keyword <code>tx</code> to display transmit-only packet information.
	<b>rx</b>	(OPTIONAL) Enter the keyword <code>rx</code> to display receive-only packet information.
	<b>both</b>	(OPTIONAL) Enter the keyword <code>both</code> to display both receive and transmit packet information.

**Defaults** none

**Command Modes** EXEC Privilege

**Supported Modes** All Modes

<b>Command History</b>	<b>Version</b>	<b>Description</b>
	<b>8.3.17.0</b>	Supported on the M I/O Aggregator.

## disable

Enable or disable LLDP.

**Syntax** `disable`  
To enable LLDP, use the `no disable` command.

**Defaults** Enabled, that is `no disable`.

**Command Modes** CONFIGURATION (`conf-lldp`) and INTERFACE (`conf-if-interface-lldp`)

**Supported Modes** Programmable-Mux (PMUX)

<b>Command History</b>	<b>Version</b>	<b>Description</b>
	<b>9.9(0.0)</b>	Introduced on the FN IOM.
	<b>9.4(0.0)</b>	Supported on the FN I/O Aggregator.
	<b>9.2(0.0)</b>	Introduced on the M I/O Aggregator.
	<b>8.3.16.1</b>	Introduced on the MXL 10/40GbE Switch IO Module.

**Related Commands** [debug lldp interface](#) — debugs LLDP.

# hello

Configure the rate at which the LLDP control packets are sent to its peer.

<b>Syntax</b>	<code>hello seconds</code> To revert to the default, use the <code>no hello seconds</code> command.										
<b>Parameters</b>	<b>seconds</b> Enter the rate, in seconds, at which the control packets are sent to its peer. The rate is from 5 to 180 seconds. The default is <b>30 seconds</b> .										
<b>Defaults</b>	<b>30 seconds</b>										
<b>Command Modes</b>	CONFIGURATION (conf-lldp) and INTERFACE (conf-if-interface-lldp)										
<b>Supported Modes</b>	Programmable-Mux (PMUX)										
<b>Command History</b>	<table><thead><tr><th>Version</th><th>Description</th></tr></thead><tbody><tr><td><b>9.9(0.0)</b></td><td>Introduced on the FN IOM.</td></tr><tr><td><b>9.4(0.0)</b></td><td>Supported on the FN I/O Aggregator.</td></tr><tr><td><b>9.2(0.0)</b></td><td>Introduced on the M I/O Aggregator.</td></tr><tr><td><b>8.3.16.1</b></td><td>Introduced on the MXL 10/40GbE Switch IO Module.</td></tr></tbody></table>	Version	Description	<b>9.9(0.0)</b>	Introduced on the FN IOM.	<b>9.4(0.0)</b>	Supported on the FN I/O Aggregator.	<b>9.2(0.0)</b>	Introduced on the M I/O Aggregator.	<b>8.3.16.1</b>	Introduced on the MXL 10/40GbE Switch IO Module.
Version	Description										
<b>9.9(0.0)</b>	Introduced on the FN IOM.										
<b>9.4(0.0)</b>	Supported on the FN I/O Aggregator.										
<b>9.2(0.0)</b>	Introduced on the M I/O Aggregator.										
<b>8.3.16.1</b>	Introduced on the MXL 10/40GbE Switch IO Module.										

# multiplier

Set the number of consecutive misses before LLDP declares the interface dead.

<b>Syntax</b>	<code>multiplier integer</code> To return to the default, use the <code>no multiplier integer</code> command.										
<b>Parameters</b>	<b>integer</b> Enter the number of consecutive misses before the LLDP declares the interface dead. The range is from 2 to 10.										
<b>Defaults</b>	<b>4 x hello</b>										
<b>Command Modes</b>	CONFIGURATION (conf-lldp) and INTERFACE (conf-if-interface-lldp)										
<b>Supported Modes</b>	Programmable-Mux (PMUX)										
<b>Command History</b>	<table><thead><tr><th>Version</th><th>Description</th></tr></thead><tbody><tr><td><b>9.9(0.0)</b></td><td>Introduced on the FN IOM.</td></tr><tr><td><b>9.4(0.0)</b></td><td>Supported on the FN I/O Aggregator.</td></tr><tr><td><b>9.2(0.0)</b></td><td>Introduced on the M I/O Aggregator.</td></tr><tr><td><b>8.3.16.1</b></td><td>Introduced on the MXL 10/40GbE Switch IO Module.</td></tr></tbody></table>	Version	Description	<b>9.9(0.0)</b>	Introduced on the FN IOM.	<b>9.4(0.0)</b>	Supported on the FN I/O Aggregator.	<b>9.2(0.0)</b>	Introduced on the M I/O Aggregator.	<b>8.3.16.1</b>	Introduced on the MXL 10/40GbE Switch IO Module.
Version	Description										
<b>9.9(0.0)</b>	Introduced on the FN IOM.										
<b>9.4(0.0)</b>	Supported on the FN I/O Aggregator.										
<b>9.2(0.0)</b>	Introduced on the M I/O Aggregator.										
<b>8.3.16.1</b>	Introduced on the MXL 10/40GbE Switch IO Module.										

# protocol lldp (Configuration)

Enable LLDP globally on the switch.

<b>Syntax</b>	<code>protocol lldp</code> To disable LLDP globally on the chassis, use the <code>no protocol lldp</code> command.
<b>Defaults</b>	Enabled.



**Command Modes** CONFIGURATION (conf-lldp)

**Supported Modes** All Modes

<b>Command History</b>	<b>Version</b>	<b>Description</b>
	<b>9.9(0.0)</b>	Introduced on the FN IOM.
	<b>9.4(0.0)</b>	Supported on the FN I/O Aggregator.
	<b>8.3.17.0</b>	Supported on the M I/O Aggregator.

## protocol lldp (Interface)

Enter the LLDP protocol in the INTERFACE mode.

**Syntax** `[no] protocol lldp`  
To return to the global LLDP configuration mode, use the `no protocol lldp` command from Interface mode.

**Defaults** Enabled

**Command Modes** INTERFACE (conf-if-interface-*lldp*)

**Supported Modes** All Modes

<b>Command History</b>	<b>Version</b>	<b>Description</b>
	<b>9.9(0.0)</b>	Introduced on the FN IOM.
	<b>9.4(0.0)</b>	Supported on the FN I/O Aggregator.
	<b>8.3.17.0</b>	Supported on the M I/O Aggregator.

**Usage Information** This command is available only in PMUX mode.  
By default, protocol lldp is enabled, To disable, use the `no protocol lldp` command.  
When you enter the LLDP protocol in the Interface context, it overrides global configurations. When you execute the `no protocol lldp` from INTERFACE mode, interfaces begin to inherit the configuration from global LLDP CONFIGURATION mode.

## show lldp neighbors

Display LLDP neighbor information for all interfaces or a specified interface.

**Syntax** `show lldp neighbors [interface] [detail]`

**Parameters**

<b><i>interface</i></b>	(OPTIONAL) Enter the following keywords and slot/port or number information: <ul style="list-style-type: none"><li>For a 10-Gigabit Ethernet interface, enter the keyword <code>tenGigabitEthernet</code> then the slot/port information.</li></ul>
<b><i>detail</i></b>	(OPTIONAL) Enter the keyword <code>detail</code> to display all the TLV information, timers, and LLDP tx and rx counters.

**Defaults** none

**Command Modes** EXEC Privilege

**Supported Modes** All Modes

<b>Command History</b>	<b>Version</b>	<b>Description</b>
	<b>8.3.17.0</b>	Supported on the M I/O Aggregator.

**Usage Information**

Omitting the keyword `detail` displays only the remote chassis ID, Port ID, and Dead Interval.

**Example**

```
Dell (conf-if-te-1/31)#do show lldp neighbors
Loc PortID      Rem Host Name  Rem Port Id      Rem Chassis Id
-----
Te 1/37         FTOS           TenGigabitEthernet 0/37  00:01:e8:05:40:46
Te 1/38         FTOS           TenGigabitEthernet 0/38  00:01:e8:05:40:46
Te 1/39         FTOS           TenGigabitEthernet 0/39  00:01:e8:05:40:46
Te 1/40         FTOS           TenGigabitEthernet 0/40  00:01:e8:05:40:46
Dell (conf-if-te-1/31)#
```

## show lldp statistics

Displays the LLDP statistical information.

**Syntax** show lldp statistics

**Defaults** none

**Command Modes** EXEC Privilege

**Supported Modes** All Modes

Command History	Version	Description
	<b>9.9(0.0)</b>	Introduced on the FN IOM.
	<b>9.4(0.0)</b>	Supported on the FN I/O Aggregator.
	<b>8.3.17.0</b>	Supported on the M I/O Aggregator.

**Example**

```
Dell#show lldp statistics
----- LLDP GLOBAL STATISTICS ON CHASSIS -----
Total number of neighbors: 4
Last table change time: 00:01:17, In ticks: 3859
Total number of Table Inserts: 7
Total number of Table Deletes: 3
Total number of Table Drops: 0
Total number of Table Age Outs: 0
Dell#
```

# Object Tracking

Object Tracking supports IPv4 and IPv6, and is available on the Dell Networking platforms.

Object tracking allows you to define objects of interest, monitor their state, and report to a client when a change in an object's state occurs. The following tracked objects are supported:

- Link status of Layer 2 interfaces
- Routing status of Layer 3 interfaces (IPv4 and IPv6)
- Reachability of IPv4 and IPv6 routes
- Metric thresholds of IPv4 and IPv6 routes

You can configure client applications, such virtual router redundancy protocol (VRRP), to receive a notification when the state of a tracked object changes.

## Topics:

- [IPv4 Object Tracking Commands](#)
- [IPv6 Object Tracking Commands](#)

## IPv4 Object Tracking Commands

The following section describes the IPv4 VRRP commands.

### debug track

Enables debugging for tracked objects.

**Syntax** `debug track [all | notifications | object-id]`

**Parameters**

- all** Enables debugging on the state and notifications of all tracked objects.
- notifications** Enables debugging on the notifications of all tracked objects.
- object-id*** Enables debugging on the state and notifications of the specified tracked object. The range is 1 to 500.

**Defaults** Enable debugging on the state and notifications of all tracked objects (`debug track all`).

**Command Modes**

- EXEC
- EXEC Privilege

#### Command History

Version	Description
9.7(0.0)	Introduced on the M I/O Aggregator.

#### Example

```
Dell#debug track all

04:35:04: %RPM0-P:RP2 %OTM-5-STATE: track 6 - Interface
TenGigabitEthernet 1/2
line-protocol DOWN

04:35:04: %RPM0-P:RP2 %OTM-5-NOTIF: VRRP notification: resource ID 6 DOWN
```

## delay

Configure the time delay used before communicating a change in the status of a tracked object to clients.

**Syntax** `delay {[up seconds] [down seconds]}`

To return to the default setting, use the `no delay` command.

**Parameters** **seconds** Enter the number of seconds the object tracker waits before sending a notification about the change in the UP and/or DOWN state of a tracked object to clients. The range is 0 to 180. The default is **0 seconds**.

**Defaults** **0 seconds**

**Command Modes** OBJECT TRACKING (*conf\_track\_object-id*)

Command History	Version	Description
	9.7(0.0)	Introduced on the M I/O Aggregator.

**Usage Information** You can configure an UP and/or DOWN timer for each tracked object to set the time delay before a change in the state of a tracked object is communicated to clients. The configured time delay starts when the state changes from UP to DOWN or vice-versa.

If the state of an object changes back to its former UP/DOWN state before the timer expires, the timer is cancelled and the client is not notified. For example, if the DOWN timer is running when an interface goes down and comes back up, the DOWN timer is cancelled and the client is not notified of the event.

If the timer expires and an object's state has changed, a notification is sent to the client. If no delay is configured, a notification is sent immediately after a change in the state of a tracked object is detected. The time delay in communicating a state change is specified in seconds.

## description

Enter a description of a tracked object.

**Syntax** `description {text}`

To remove the description, use the `no description {text}` command.

**Parameters** **text** Enter a description to identify a tracked object (80 characters maximum).

**Defaults** none

**Command Modes** OBJECT TRACKING (*conf\_track\_object-id*)

Command History	Version	Description
	9.7(0.0)	Introduced on the M I/O Aggregator.

**Related Commands**

- [track interface ip routing](#) – configures object tracking on the routing status of an IPv4 Layer 3 interface.
- [track interface line-protocol](#) – configures object tracking on the line-protocol state of a Layer 2 interface.
- [track ip route metric threshold](#) – configures object tracking on the threshold of an IPv4 route metric.
- [track ip route reachability](#) – configures object tracking on the reachability of an IPv4 route.

## show running-config track

Display the current configuration of tracked objects.

**Syntax** `show running-config track [object-id]`

**Parameters**      *object-id*      (OPTIONAL) Display information on the specified tracked object. The range is 1 to 500.

**Command Modes** EXEC Privilege

<b>Command History</b>	<b>Version</b>	<b>Description</b>
	<b>9.7(0.0)</b>	Introduced on the M I/O Aggregator.

**Example**

```
Dell#show running-config track

track 1 ip route 23.0.0.0/8 reachability

track 2 ipv6 route 2040::/64 metric threshold
delay down 3
delay up 5
threshold metric up 200

track 3 ipv6 route 2050::/64 reachability

track 4 interface TenGigabitEthernet 1/2 ip routing

track 5 ip route 192.168.0.0/24 reachability vrf red

track resolution ip route isis 20
track resolution ip route ospf 10
```

**Example (Object-id)**

```
Dell#show running-config track 300

track 300 ip route 10.0.0.0/8 metric threshold
delay down 3
delay up 5
threshold metric up 100
```

- Related Commands**
- [track ip route metric threshold](#) – configures object tracking on the threshold of an IPv4 route metric.
  - [track ip route reachability](#) – configures object tracking on the reachability of an IPv4 route.

## show track

Display information about tracked objects, including configuration, current tracked state (UP or DOWN), and the clients which are tracking an object.

**Syntax**      show track [*object-id* [brief] | interface [brief] | ip route [brief] | resolution | [brief] | brief]

<b>Parameters</b>	<i>object-id</i>	(OPTIONAL) Display information on the specified tracked object. The range is 1 to 500.
	<b>interface</b>	(OPTIONAL) Display information on all tracked interfaces (Layer 2 and IPv4 Layer 3).
	<b>ip route</b>	(OPTIONAL) Display information on all tracked IPv4 routes.
	<b>resolution</b>	(OPTIONAL) Display information on the configured resolution values used to scale protocol-specific route metrics. The range is 0 to 255.
	<b>brief</b>	(OPTIONAL) Display a single line summary of the tracking information for a specified object, object type, or all tracked objects.

**Command Modes** EXEC Privilege

<b>Command History</b>	<b>Version</b>	<b>Description</b>
	<b>9.7(0.0)</b>	Introduced on the M I/O Aggregator.

## Usage Information

The following describes the `show track` command shown in the Example below.

Output	Description
<b>Track <i>object-id</i></b>	Displays the number of the tracked object.
<b>Interface <i>type slot/port, IP route ip-address, IPv6 route ipv6-address</i></b>	Displays the interface type and slot/port number or address of the IPv4/IPv6 route that is being tracked.
<b><i>object is Up/Down</i></b>	Up/Down state of tracked object; for example, IPv4 interface, reachability or metric threshold of an IP route.
<b><i>number changes, last change time</i></b>	Number of times that the state of the tracked object has changed and the time since the last change in <i>hours:minutes:seconds</i> .
<b>First hop interface</b>	Displays the type and slot/port number of the first-hop interface of the tracked route.
<b>Tracked by</b>	Client that is tracking an object's state; for example, VRRP.

## Example

```
Dell#show track

Track 1
  IP route 23.0.0.0/8 reachability
  Reachability is Down (route not in route table)
  2 changes, last change 00:16:08
  Tracked by:

Track 2
  IPv6 route 2040::/64 metric threshold
  Metric threshold is Up (STATIC/0/0)
  5 changes, last change 00:02:16
  Metric threshold down 255 up 254
  First-hop interface is TenGigabitEthernet 1/2
  Tracked by:
    VRRP TenGigabitEthernet 2/3 IPv6 VRID 1

Track 3
  IPv6 route 2050::/64 reachability
  Reachability is Up (STATIC)
  5 changes, last change 00:02:16
  First-hop interface is TenGigabitEthernet 1/2
  Tracked by:
    VRRP TenGigabitEthernet 2/3 IPv6 VRID 1
```

## Usage Information

The following describes the `show track brief` command shown in the Example below.

Output	Description
<b>ResID</b>	Number of the tracked object.
<b>Resource</b>	Type of tracked object.
<b>Parameter</b>	Detailed description of the tracked object.
<b>State</b>	Up or Down state of the tracked object.
<b>Last Change</b>	Time since the last change in the state of the tracked object.

## Example (Brief)

```
Dell>show track brief
ResID Resource                Parameter      State LastChange
1     IP route reachability      10.16.0.0/16 Up    00:01:08
2     Interface line-protocol Ethernet0/2 Down  00:05:00
3     Interface ip routing      VLAN100      Up    01:10:05
```

## threshold metric

Configure the metric threshold used to determine the UP and/or DOWN state of a tracked IPv4 or IPv6 route.

<b>Syntax</b>	<code>threshold metric {up <i>number</i>   down <i>number</i>}</code> To return to the default setting, use the <code>no threshold metric {up <i>number</i>   down <i>number</i>}</code> command.				
<b>Parameters</b>	<table><tr><td><b>up <i>number</i></b></td><td>Enter a number for the UP threshold to be applied to the scaled metric of an IPv4 or IPv6 route. The default UP threshold is <b>254</b>. The routing state is UP if the scaled route metric is less than or equal to the UP threshold.</td></tr><tr><td><b>down <i>number</i></b></td><td>Enter a number for the DOWN threshold to be applied to the scaled metric of an IPv4 or IPv6 route. The default DOWN threshold is <b>255</b>. The routing state is DOWN if the scaled route metric is greater than or equal to the DOWN threshold.</td></tr></table>	<b>up <i>number</i></b>	Enter a number for the UP threshold to be applied to the scaled metric of an IPv4 or IPv6 route. The default UP threshold is <b>254</b> . The routing state is UP if the scaled route metric is less than or equal to the UP threshold.	<b>down <i>number</i></b>	Enter a number for the DOWN threshold to be applied to the scaled metric of an IPv4 or IPv6 route. The default DOWN threshold is <b>255</b> . The routing state is DOWN if the scaled route metric is greater than or equal to the DOWN threshold.
<b>up <i>number</i></b>	Enter a number for the UP threshold to be applied to the scaled metric of an IPv4 or IPv6 route. The default UP threshold is <b>254</b> . The routing state is UP if the scaled route metric is less than or equal to the UP threshold.				
<b>down <i>number</i></b>	Enter a number for the DOWN threshold to be applied to the scaled metric of an IPv4 or IPv6 route. The default DOWN threshold is <b>255</b> . The routing state is DOWN if the scaled route metric is greater than or equal to the DOWN threshold.				
<b>Defaults</b>	none				
<b>Command Modes</b>	OBJECT TRACKING ( <i>conf_track_object-id</i> )				
<b>Command History</b>	<table><thead><tr><th>Version</th><th>Description</th></tr></thead><tbody><tr><td><b>9.7(0.0)</b></td><td>Introduced on the M I/O Aggregator.</td></tr></tbody></table>	Version	Description	<b>9.7(0.0)</b>	Introduced on the M I/O Aggregator.
Version	Description				
<b>9.7(0.0)</b>	Introduced on the M I/O Aggregator.				
<b>Usage Information</b>	<p>Use this command to configure the UP and/or DOWN threshold for the scaled metric of a tracked IPv4 or IPv6 route.</p> <p>Determine the UP/DOWN state of a tracked route by the threshold for the current value of the route metric in the routing table. To provide a common tracking interface for different clients, route metrics are scaled in the range 0 to 255, where 0 is connected and 255 is inaccessible. The scaled metric value communicated to a client always considers a lower value to have priority over a higher value.</p> <p>The resulting scaled value is compared against the configured threshold values to determine the state of a tracked route as follows:</p> <ul style="list-style-type: none"><li>• If the scaled metric for a route entry is less than or equal to the UP threshold, the state of a route is UP.</li><li>• If the scaled metric for a route is greater than or equal to the DOWN threshold or the route is not entered in the routing table, the state of a route is DOWN.</li></ul> <p>Configure the UP and DOWN thresholds for each tracked route with the <code>threshold metric</code> command. The default UP threshold is 254; the default DOWN threshold is 255. The notification of a change in the state of a tracked object is sent when a metric value crosses a configured threshold.</p> <p>The tracking process uses a protocol-specific resolution value to convert the actual metric in the routing table to a scaled metric in the range 0 to 255. You can configure the resolution value used to scale route metrics for supported protocols with the <code>track resolution ip route</code> and <code>track resolution ipv6 route</code> commands.</p>				

## track interface ip routing

Configure object tracking on the routing status of an IPv4 Layer 3 interface.

<b>Syntax</b>	<code>track <i>object-id</i> interface <i>interface</i> ip routing</code> To return to the default setting, use the <code>no track <i>object-id</i></code> command.				
<b>Parameters</b>	<table><tr><td><b><i>object-id</i></b></td><td>Enter the ID number of the tracked object. The range is 1 to 500.</td></tr><tr><td><b><i>interface</i></b></td><td>Enter one of the following values:<ul style="list-style-type: none"><li>• For a 10-Gigabit Ethernet interface, enter the keyword <code>TenGigabitEthernet</code> then the slot/port information.</li><li>• For a 40-Gigabit Ethernet interface, enter the keyword <code>fortyGigE</code> then the slot/port information.</li></ul></td></tr></table>	<b><i>object-id</i></b>	Enter the ID number of the tracked object. The range is 1 to 500.	<b><i>interface</i></b>	Enter one of the following values: <ul style="list-style-type: none"><li>• For a 10-Gigabit Ethernet interface, enter the keyword <code>TenGigabitEthernet</code> then the slot/port information.</li><li>• For a 40-Gigabit Ethernet interface, enter the keyword <code>fortyGigE</code> then the slot/port information.</li></ul>
<b><i>object-id</i></b>	Enter the ID number of the tracked object. The range is 1 to 500.				
<b><i>interface</i></b>	Enter one of the following values: <ul style="list-style-type: none"><li>• For a 10-Gigabit Ethernet interface, enter the keyword <code>TenGigabitEthernet</code> then the slot/port information.</li><li>• For a 40-Gigabit Ethernet interface, enter the keyword <code>fortyGigE</code> then the slot/port information.</li></ul>				

- For a Loopback interface, enter the keyword `loopback` then a number from 0 to 16383.
- For a port channel interface, enter the keywords `port-channel` then a number.
- For a tunnel interface, enter the keyword `tunnel`.
- For a VLAN interface, enter the keyword `vlan` then a number from 1 to 4094.

**Defaults** none

**Command Modes** CONFIGURATION

Command History	Version	Description
	9.7(0.0)	Introduced on the M I/O Aggregator. Added support for <code>tunnel</code> interface.

**Usage Information** Use this command to create an object that tracks the routing state of an IPv4 Layer 2 interface:

- The status of the IPv4 interface is UP only if the Layer 2 status of the interface is UP and the interface has a valid IP address.
- The Layer 3 status of an IPv4 interface goes DOWN when its Layer 2 status goes down (for a Layer 3 VLAN, all VLAN ports must be down) or the IP address is removed from the routing table.

## track interface line-protocol

Configure object tracking on the line-protocol state of a Layer 2 interface.

**Syntax** `track object-id interface interface line-protocol`

To return to the default setting, use the `no track object-id` command.

**Parameters**

<b><i>object-id</i></b>	Enter the ID number of the tracked object. The range is 1 to 500.
<b><i>interface</i></b>	Enter one of the following values: <ul style="list-style-type: none"> <li>• For a 10-Gigabit Ethernet interface, enter the keyword <code>TenGigabitEthernet</code> then the slot/port information.</li> <li>• For a 40-Gigabit Ethernet interface, enter the keyword <code>fortyGigE</code> then the slot/port information.</li> <li>• For a Loopback interface, enter the keyword <code>loopback</code> then a number from 0 to 16383.</li> <li>• For a port channel interface, enter the keywords <code>port-channel</code> then a number.</li> <li>• For a tunnel interface, enter the keyword <code>tunnel</code>.</li> <li>• For a VLAN interface, enter the keyword <code>vlan</code> then a number from 1 to 4094.</li> </ul>

**Defaults** none

**Command Modes** CONFIGURATION

Command History	Version	Description
	9.7(0.0)	Introduced on the M I/O Aggregator.

**Usage Information** Use this command to create an object that tracks the line-protocol state of a Layer 2 interface by monitoring its operational status (UP or DOWN).

When the link-level status goes down, the tracked object status is considered to be DOWN; if the link-level status is up, the tracked object status is considered to be UP.

**Related Commands**

- [show track](#) – displays information about tracked objects, including configuration, current state, and clients which track the object.
- [track interface ip routing](#) – configures object tracking on the routing status of an IPv4 Layer 3 interface.



## track ip route metric threshold

Configure object tracking on the threshold of an IPv4 route metric.

**Syntax** `track object-id ip route ip-address/prefix-len metric threshold`

To return to the default setting, use the `no track object-id` command.

**Parameters**

<b><i>object-id</i></b>	Enter the ID number of the tracked object. The range is 1 to 500.
<b><i>ip-address/prefix-len</i></b>	Enter an IPv4 address in dotted decimal format. The valid IPv4 prefix lengths are from /0 to /32.

**Defaults** none

**Command Modes** CONFIGURATION

**Command History**

Version	Description
---------	-------------

<b>9.7(0.0)</b>	Introduced on the M I/O Aggregator.
-----------------	-------------------------------------

### Usage Information

Use this command to create an object that tracks the UP and/or DOWN threshold of an IPv4 route metric. In order for a route's metric to be tracked, the route must appear as an entry in the routing table.

A tracked IPv4 route is considered to match an entry in the routing table only if the exact IPv4 address and prefix length match a table entry. For example, when configured as a tracked route, 10.0.0.0/24 does not match the routing table entry 10.0.0.0/8. If no route-table entry has the exact IPv4 address and prefix length, the status of the tracked route is considered to be DOWN.

When you configure the threshold of an IPv4 route metric as a tracked object, the UP/DOWN state of the tracked route is also determined by the current metric for the route in the routing table.

To provide a common tracking interface for different clients, route metrics are scaled in the range 0 to 255, where 0 is connected and 255 is inaccessible. The scaled metric value communicated to a client always considers a lower value to have priority over a higher value. The resulting scaled value is compared against the configured threshold values to determine the state of a tracked route as follows:

- If the scaled metric for a route entry is less than or equal to the UP threshold, the state of a route is UP.
- If the scaled metric for a route is greater than or equal to the DOWN threshold or the route is not entered in the routing table, the state of a route is DOWN.

You configure the UP and DOWN thresholds for each tracked route by using the `threshold metric` command. The default UP threshold is **254**; the default DOWN threshold is **255**. The notification of a change in the state of a tracked object is sent when a metric value crosses a configured threshold.

### Related Commands

- [show track](#) – displays information about tracked objects, including configuration, current state, and clients which track the object.
- [threshold metric](#) – configures the metric threshold used to determine the UP and/or DOWN state of a tracked route.
- [track resolution ip route](#) – configures the protocol-specific resolution value used to scale an IPv4 route metric.

## track ip route reachability

Configure object tracking on the reachability of an IPv4 route.

**Syntax** `track object-id ip route ip-address/prefix-len reachability [vrf vrf-name]`

To return to the default setting, use the `no track object-id` command.

**Parameters**

<b><i>object-id</i></b>	Enter the ID number of the tracked object. The range is 1 to 500.
<b><i>ip-address/prefix-len</i></b>	Enter an IPv4 address in dotted decimal format. The valid IPv4 prefix lengths are from /0 to /32.

**vrf *vrf-name*** (Optional) E-Series only: You can configure a VPN routing and forwarding (VRF) instance to specify the virtual routing table to which the tracked route belongs.

**Defaults** none

**Command Modes** CONFIGURATION

**Command History**

Version	Description
9.7(0.0)	Introduced on the M I/O Aggregator.

**Usage Information**

Use this command to create an object that tracks the reachability of an IPv4 route. In order for a route's reachability to be tracked, the route must appear as an entry in the routing table.

A tracked IPv4 route is considered to match an entry in the routing table only if the exact IPv4 address and prefix length match a table entry. For example, when configured as a tracked route, 10.0.0.0/24 does not match the routing table entry 10.0.0.0/8. If no route-table entry has the exact IPv4 address and prefix length, the status of the tracked route is considered to be DOWN.

When you configure IPv4 route reachability as a tracked object, the UP/DOWN state of the tracked route is also determined by the entry of the next-hop address in the ARP cache. A tracked route is considered to be reachable if there is an ARP cache entry for the route's next-hop address.

If the next-hop address in the ARP cache ages out for a route tracked for its reachability, an attempt is made to regenerate the ARP cache entry to if the next-hop address appears before considering the route DOWN.

**Related Commands**

- [show track](#) – displays information about tracked objects, including configuration, current state, and clients which track the object.
- [track ip route metric threshold](#) – configures object tracking on the threshold of an IPv4 route metric.

## track resolution ip route

Configure the protocol-specific resolution value used to scale an IPv4 route metric.

**Syntax** `track resolution ip route {isis resolution-value | ospf resolution-value}`  
To return to the default setting, use the `no track object-id` command.

**Parameters**

<b><i>object-id</i></b>	Enter the ID number of the tracked object. The range is 1 to 500.
<b><i>isis resolution-value</i></b>	Enter the resolution used to convert the metric in the routing table for ISIS routes to a scaled metric.
<b><i>ospf resolution-value</i></b>	Enter the resolution used to convert the metric in the routing table for OSPF routes to a scaled metric.

**Defaults** none

**Command Modes** CONFIGURATION

**Command History**

Version	Description
9.7(0.0)	Introduced on the M I/O Aggregator.

**Usage Information**

Use this command to configure the protocol-specific resolution value that converts the actual metric of an IPv4 route in the routing table to a scaled metric in the range 0 to 255.

The UP/DOWN state of a tracked IPv4 route is determined by a user-configurable threshold (the `threshold metric` command) for the route's metric in the routing table. To provide a common tracking interface for different clients, route metrics are scaled in the range 0 to 255, where 0 is connected and 255 is inaccessible.

The protocol-specific resolution value calculates the scaled metric by dividing a route's cost by the resolution value set for the route protocol:

- For ISIS, you can set the resolution in the range 1 to 1000, where the default is **10**.

- For OSPF, you can set the resolution in the range 1 to 1592, where the default is **1**.
- The resolution value used to map static routes is not configurable. By default, Dell Networking OS assigns a metric of **0** to static routes.
- The resolution value used to map RIP routes is not configurable. The RIP hop-count is automatically multiplied by 16 to scale it. For example, a RIP metric of 16 (unreachable) scales to 256, which considers the route to be DOWN.

#### Related Commands

- [threshold metric](#) – configures the metric threshold used to determine the UP and/or DOWN state of a tracked route.
- [track ip route metric threshold](#) – configures object tracking on the threshold of an IPv4 route metric.

## IPv6 Object Tracking Commands

The following object tracking commands apply to IPv4 and IPv6:

- [debug track](#)
- [delay](#)
- [description](#)
- [show running-config track](#)
- [threshold metric](#)
- [track interface line-protocol](#)

### show track ipv6 route

Display information about all tracked IPv6 routes, including configuration, current tracked state (UP or DOWN), and the clients which are tracking an object.

**Syntax** `show track ipv6 route [brief]`

**Parameters** **brief** (OPTIONAL) Display a single line summary of information for tracked IPv6 routes.

**Command Modes**

- EXEC
- EXEC Privilege

Command History	Version	Description
	9.7(0.0)	Introduced on the M I/O Aggregator.

**Usage Information** The following describes the `show track ipv6 route` command shown in the Example below.

Output	Description
<b>Track <i>object-id</i></b>	Displays the number of the tracked object.
<b>Interface <i>type slot/port, IP route ip-address, IPv6 route ipv6-address</i></b>	Displays the interface type and slot/port number or address of the IPv4/IPv6 route that is being tracked.
<b><i>object is Up/Down</i></b>	Up/Down state of tracked object; for example, IPv4 interface, reachability or metric threshold of an IP route.
<b><i>number changes, last change time</i></b>	Number of times that the state of the tracked object has changed and the time since the last change in <i>hours:minutes:seconds</i> .
<b>First hop interface</b>	Displays the type and slot/port number of the first-hop interface of the tracked route.
<b>Tracked by</b>	Client that is tracking an object's state; for example, VRRP.

## Example

```
Dell#show track ipv6 route

Track 2
  IPv6 route 2040::/64 metric threshold
  Metric threshold is Up (STATIC/0/0)
    5 changes, last change 00:02:30
  Metric threshold down 255 up 254
  First-hop interface is TenGigabitEthernet 1/2
  Tracked by:
    VRRP TenGigabitEthernet 2/4 IPv6 VRID 1

Track 3
  IPv6 route 2050::/64 reachability
  Reachability is Up (STATIC)
    5 changes, last change 00:02:30
  First-hop interface is TenGigabitEthernet 1/2
  Tracked by:
    VRRP TenGigabitEthernet 2/4 IPv6 VRID 1
```

**Usage Command** The following describes the show track ipv6 route brief command shown in the Example below.

Ouput	Description
<b>ResID</b>	Number of the tracked object.
<b>Resource</b>	Type of tracked object.
<b>Parameter</b>	Detailed description of the tracked object.
<b>State</b>	Up or Down state of the tracked object.
<b>Last Change</b>	Time since the last change in the state of the tracked object.

## Example (Brief)

```
Dell#show track ipv6 route brief

ResId Resource                               Parameter State LastChange
  2     IPv6 route metric threshold 2040::/64 Up 00:02:36
  3     IPv6 route reachability      2050::/64 Up 00:02:36
```

## track interface ipv6 routing

Configure object tracking on the routing status of an IPv6 Layer 3 interface.

**Syntax** `track object-id interface interface ipv6 routing`

To return to the default setting, use the `no track object-id` command.

### Parameters

<b><i>object-id</i></b>	Enter the ID number of the tracked object. The range is 1 to 500.
<b><i>interface</i></b>	Enter one of the following values: <ul style="list-style-type: none"><li>For a 10-Gigabit Ethernet interface, enter the keyword <code>TenGigabitEthernet</code> then the slot/port information.</li><li>For a 40-Gigabit Ethernet interface, enter the keyword <code>fortyGigE</code> then the slot/port information.</li><li>For a Loopback interface, enter the keyword <code>loopback</code> then a number from 0 to 16383.</li><li>For a port channel interface, enter the keywords <code>port-channel</code> then a number.</li><li>For a tunnel interface, enter the keyword <code>tunnel</code>.</li><li>For a VLAN interface, enter the keyword <code>vlan</code> then a number from 1 to 4094.</li></ul>

**Defaults** none

**Command Modes** CONFIGURATION

<b>Command History</b>	<table border="0"> <thead> <tr> <th style="text-align: left;">Version</th> <th style="text-align: left;">Description</th> </tr> </thead> <tbody> <tr> <td><b>9.7(0.0)</b></td> <td>Introduced on the M I/O Aggregator.</td> </tr> </tbody> </table>	Version	Description	<b>9.7(0.0)</b>	Introduced on the M I/O Aggregator.
Version	Description				
<b>9.7(0.0)</b>	Introduced on the M I/O Aggregator.				
<b>Usage Information</b>	<p>Use this command to create an object that tracks the routing state of an IPv6 Layer 3 interface:</p> <ul style="list-style-type: none"> <li>• The status of the IPv6 interface is UP only if the Layer 2 status of the interface is UP and the interface has a valid IP address.</li> <li>• The Layer 3 status of an IPv6 interface goes DOWN when its Layer 2 status goes down (for a Layer 3 VLAN, all VLAN ports must be down) or the IP address is removed from the routing table.</li> </ul>				
<b>Related Commands</b>	<ul style="list-style-type: none"> <li>• <a href="#">show track ipv6 route</a> – displays information about tracked IPv6 routes, including configuration, current state, and clients which track the route.</li> <li>• <a href="#">track interface ip routing</a> – configures object tracking on the routing status of an IPv4 Layer 3 interface.</li> </ul>				

## track ipv6 route metric threshold

Configure object tracking on the threshold of an IPv4 route metric.

**Syntax** `track object-id ipv6 route ipv6-address/prefix-len metric threshold`  
 To return to the default setting, use the `no track object-id` command.

**Parameters**

<b><i>object-id</i></b>	Enter the ID number of the tracked object. The range is 1 to 500.
<b><i>ipv6-address/prefix-len</i></b>	Enter an IPv6 address in X:X:X:X format. The valid IPv6 prefix lengths are from /0 to /128.

**Defaults** none

**Command Modes** CONFIGURATION

<b>Command History</b>	<table border="0"> <thead> <tr> <th style="text-align: left;">Version</th> <th style="text-align: left;">Description</th> </tr> </thead> <tbody> <tr> <td><b>9.7(0.0)</b></td> <td>Introduced on the M I/O Aggregator.</td> </tr> </tbody> </table>	Version	Description	<b>9.7(0.0)</b>	Introduced on the M I/O Aggregator.
Version	Description				
<b>9.7(0.0)</b>	Introduced on the M I/O Aggregator.				

**Usage Information** Use this command to create an object that tracks the UP and/or DOWN threshold of an IPv6 route metric. In order for a route's metric to be tracked, the route must appear as an entry in the routing table.

A tracked IPv6 route is considered to match an entry in the routing table only if the exact IPv6 address and prefix length match a table entry. For example, when configured as a tracked route, 3333:100:200:300:400::/80 does not match routing table entry 3333:100:200:300::/64. If no route-table entry has the exact IPv6 address and prefix length, the status of the tracked route is considered to be DOWN.

When you configure the threshold of an IPv6 route metric as a tracked object, the UP/DOWN state of the tracked route is also determined by the current metric for the route in the routing table.

To provide a common tracking interface for different clients, route metrics are scaled in the range 0 to 255, where 0 is connected and 255 is inaccessible. The scaled metric value communicated to a client always considers a lower value to have priority over a higher value. The resulting scaled value is compared against the configured threshold values to determine the state of a tracked route as follows:

- If the scaled metric for a route entry is less than or equal to the UP threshold, the state of a route is UP.
- If the scaled metric for a route is greater than or equal to the DOWN threshold or the route is not entered in the routing table, the state of a route is DOWN.

You configure the UP and DOWN thresholds for each tracked IPv6 route by using the `threshold metric` command. The default UP threshold is **254**; the default DOWN threshold is **255**. The notification of a change in the state of a tracked object is sent when a metric value crosses a configured threshold.

**Related Commands**

- [show track ipv6 route](#) – displays information about tracked IPv6 routes, including configuration, current state, and clients which track the route.
- [threshold metric](#) – configures the metric threshold used to determine the UP and/or DOWN state of a tracked route.

- [track resolution ipv6 route](#) – configures the protocol-specific resolution value used to scale an IPv6 route metric.

## track ipv6 route reachability

Configure object tracking on the reachability of an IPv6 route.

**Syntax** `track object-id ipv6 route ip-address/prefix-len reachability`  
 To return to the default setting, use the `no track object-id` command.

**Parameters**

<b><i>object-id</i></b>	Enter the ID number of the tracked object. The range is 1 to 500.
<b><i>ipv6-address/prefix-len</i></b>	Enter an IPv6 address in X:X:X:X format. The valid IPv6 prefix lengths are from /0 to /128.

**Defaults** none

**Command Modes** CONFIGURATION

<b>Command History</b>	<b>Version</b>	<b>Description</b>
	<b>9.7(0.0)</b>	Introduced on the M I/O Aggregator.

**Usage Information** Use this command to create an object that tracks the reachability of an IPv6 route. In order for a route's reachability to be tracked, the route must appear as an entry in the routing table.

A tracked route is considered to match an entry in the routing table only if the exact IPv6 address and prefix length match a table entry. For example, when configured as a tracked route, 3333:100:200:300:400::/80 does not match routing table entry 3333:100:200:300::/64. If no route-table entry has the exact IPv6 address and prefix length, the tracked route is considered to be DOWN.

When you configure IPv6 route reachability as a tracked object, the UP/DOWN state of the tracked route is also determined by the entry of the next-hop address in the ARP cache. A tracked route is considered to be reachable if there is an ARP cache entry for the route's next-hop address.

If the next-hop address in the ARP cache ages out for a route tracked for its reachability, an attempt is made to regenerate the ARP cache entry to if the next-hop address appears before considering the route DOWN.

**Related Commands**

- [show track ipv6 route](#) – displays information about tracked IPv6 routes, including configuration, current state, and clients which track the route.

## track resolution ipv6 route

Configure the protocol-specific resolution value used to scale an IPv6 route metric.

**Syntax** `track resolution ipv6 route {isis resolution-value | ospf resolution-value}`  
 To return to the default setting, use the `no track object-id` command.

**Parameters**

<b><i>object-id</i></b>	Enter the ID number of the tracked object. Use the range to 1 to 500.
<b><i>isis resolution-value</i></b>	Enter the resolution used to convert the metric in the routing table for ISIS routes to a scaled metric.
<b><i>ospf resolution-value</i></b>	Enter the resolution used to convert the metric in the routing table for OSPF routes to a scaled metric.

**Defaults** none

**Command Modes** CONFIGURATION

**Command History****Version****Description****9.7(0.0)**

Introduced on the M I/O Aggregator.

**Usage Information**

Use this command to configure the protocol-specific resolution value that converts the actual metric of an IPv6 route in the routing table to a scaled metric in the range 0 to 255.

The UP/DOWN state of a tracked IPv6 route is determined by the user-configurable threshold (the `threshold metric` command) for a route's metric in the routing table. To provide a common tracking interface for different clients, route metrics are scaled in the range 0 to 255, where 0 is connected and 255 is inaccessible.

The protocol-specific resolution value calculates the scaled metric by dividing a route's cost by the resolution value set for the route protocol:

- For ISIS, you can set the resolution in the range 1 to 1000, where the default is 10.
- For OSPF, you can set the resolution in the range 1 to 1592, where the default is 1.
- The resolution value used to map static routes is not configurable. By default, Dell Networking OS assigns a metric of 0 to static routes.
- The resolution value used to map RIP routes is not configurable. The RIP hop-count is automatically multiplied by 16 to scale it. For example, a RIP metric of 16 (unreachable) scales to 256, which considers the route to be DOWN.

**Related Commands**

- [threshold metric](#) – configures the metric threshold used to determine the UP and/or DOWN state of a tracked route.
- [track ipv6 route metric threshold](#)– configures object tracking on the threshold of an IPv6 route metric.

## Port Monitoring

The port monitoring feature allows you to monitor network traffic by forwarding a copy of each incoming or outgoing packet from one port to another port.

### Important Points to Remember

- Port monitoring is supported on physical ports only. Port-channel interfaces and virtual local area networks (VLANs), are not supported.
- The monitoring (destination, “MG”) and monitored (source, “MD”) ports must be on the same switch.
- The monitored (source) interface must be a server-facing interface in the format slot/port, where valid slot numbers are 0-1 and server-facing port numbers are from 1 to 32. The monitoring interface must be an uplink port in the chassis.
- Dell Networking OS permits a limited set of commands for monitoring ports. To display these commands, use the ? command.
- Only one MG and one MD may be in a single port-pipe.
- A monitoring port may not be a member of a VLAN.
- There may only be one destination port in a monitoring session.
- A source port (MD) can only be monitored by one destination port (MG). If you try to assign a monitored port to more than one monitoring port, the following error is displayed as shown in example.

#### Example

```
Dell(conf)#mon ses 1
Dell(conf-mon-sess-1)#source tengig 0/0 destination tengig 0/60
direction both
Dell(conf-mon-sess-1)#do show mon ses
SessionID Source      Destination  Direction  Mode  Type
-----
1      TenGig 0/0  TenGig 0/60  both                interface
Port-based
Dell(conf-mon-sess-1)#mon ses 2
Dell(conf-mon-sess-2)#source tengig 0/0 destination tengig 0/61
direction both
% Error: MD port is already being monitored.
```

**NOTE:** There is no limit to the number of monitoring sessions per system, provided that there are only four destination ports per port-pipe. If each monitoring session has a unique destination port, the maximum number of session is four per port-pipe.

#### Topics:

- [description](#)
- [monitor session](#)
- [show config](#)
- [show monitor session](#)
- [show running-config monitor session](#)
- [source \(port monitoring\)](#)

### description

Enter a description of this monitoring session.

**Syntax**                    `description {description}`

To remove the description, use the `no description {description}` command.



<b>Parameters</b>	<b>description</b>	Enter a description regarding this session (80 characters maximum).
<b>Defaults</b>	none	
<b>Command Modes</b>	MONITOR SESSION (conf-mon-sess-session-ID)	
<b>Supported Modes</b>	All Modes	
<b>Command History</b>	<b>Version</b>	<b>Description</b>
	<b>9.9(0.0)</b>	Introduced on the FN IOM.
	<b>9.4(0.0)</b>	Supported on the FN I/O Aggregator.
	<b>8.3.17.0</b>	Supported on the M I/O Aggregator.

## monitor session

Create a session for monitoring traffic with port monitoring.

<b>Syntax</b>	<code>monitor session session-ID</code>
	To delete a session, use the <code>no monitor session session-ID</code> command.
	To delete all monitor sessions, use the <code>no monitor session all</code> command.

<b>Parameters</b>	<b>session-ID</b>	Enter a session identification number. The range is from 0 to 65535.
-------------------	-------------------	--

**Defaults** none

**Command Modes** CONFIGURATION

**Supported Modes** All Modes

<b>Command History</b>	<b>Version</b>	<b>Description</b>
	<b>9.9(0.0)</b>	Introduced on the FN IOM.
	<b>9.4(0.0)</b>	Supported on the FN I/O Aggregator.
	<b>8.3.17.0</b>	Supported on the M I/O Aggregator.

**Usage Information** The `monitor` command is saved in the running configuration at Monitor Session mode level and can be restored after a chassis reload.

**Example**

```
Dell(conf)# monitor session 60
Dell(conf-mon-sess-60)
```

**Related Command** [show monitor session](#) — Displays the monitor session.  
[show running-config monitor session](#) — Displays the running configuration of a monitor session.

## show config

Display the current monitor session configuration.

<b>Syntax</b>	<code>show config</code>
<b>Defaults</b>	none
<b>Command Modes</b>	MONITOR SESSION (conf-mon-sess-session-ID)
<b>Supported Modes</b>	All Modes

**Command History**

Version	Description
8.3.17.0	Supported on the M I/O Aggregator.

**Example**

```
Dell(conf-mon-sess-1)#show config
!
monitor session 1
 source TenGigabitEthernet 0/1 destination Port-channel 1 direction rx
```

## show monitor session

Display the monitor information of a particular session or all sessions.

**Syntax** `show monitor session {session-ID}`  
To display monitoring information for all sessions, use the `show monitor session` command.

**Parameters** *session-ID* (OPTIONAL) Enter a session identification number. The range is from 0 to 65535.

**Defaults** none

**Command Modes**

- EXEC
- EXEC Privilege

**Supported Modes** All Modes

**Command History**

Version	Description
8.3.17.0	Supported on the M I/O Aggregator.

**Example**

```
Dell#show monitor session
  SessID  Source          Destination      Dir  Mode  Source IP
Dest IP
-----  -
-----
      1    Vl 10           Te 0/8          rx   Flow  N/A
N/A
```

**Related Commands** [monitor session](#)— creates a session for monitoring.

## show running-config monitor session

Displays the running configuration of all monitor sessions or a specific session.

**Syntax** `show running-config monitor session {session-ID}`  
To display the running configuration for all monitor sessions, use the `show running-config monitor session` command.

**Parameters** *session-ID* (OPTIONAL) Enter a session identification number. The range is from 0 to 65535.

**Defaults** none

**Command Modes**

- EXEC
- EXEC Privilege

**Supported Modes** All Modes

<b>Command History</b>	<table border="0"> <thead> <tr> <th style="text-align: left;">Version</th> <th style="text-align: left;">Description</th> </tr> </thead> <tbody> <tr> <td>8.3.17.0</td> <td>Supported on the M I/O Aggregator.</td> </tr> </tbody> </table>	Version	Description	8.3.17.0	Supported on the M I/O Aggregator.
Version	Description				
8.3.17.0	Supported on the M I/O Aggregator.				
<b>Usage Information</b>	The <code>monitoring</code> command is saved in the running configuration at the Monitor Session mode level and can be restored after a chassis reload.				
<b>Example</b>	<pre>Dell# show running-config monitor session ! monitor session 1 source TenGigabitEthernet 0/1 destination TenGigabitEthernet 0/2 direction rx</pre>				
<b>Related Commands</b>	<p><a href="#">monitor session</a>— creates a session for monitoring.</p> <p><a href="#">show monitor session</a>— displays a monitor session.</p>				

## source (port monitoring)

Configure a port monitor source.

<b>Syntax</b>	<pre>source <i>interface</i> destination <i>interface</i> direction {rx   tx   both}</pre> <p>To disable a monitor source, use the <code>no source <i>interface</i> destination <i>interface</i> direction {rx   tx   both}</code> command.</p>
<b>Parameters</b>	<p><b><i>interface</i></b> Enter the one of the following keywords and slot/port information:</p> <ul style="list-style-type: none"> <li>• For a 10-Gigabit Ethernet interface, enter the keyword <code>TenGigabitEthernet</code> then the slot/port information.</li> </ul> <p><b><i>destination</i></b> Enter the keyword <code>destination</code> to indicate the interface destination.</p> <p><b><i>direction {rx   tx   both}</i></b> Enter the keyword <code>direction</code> followed by one of the packet directional indicators.</p> <ul style="list-style-type: none"> <li>• <code>rx</code>: to monitor receiving packets only.</li> <li>• <code>tx</code>: to monitor transmitting packets only.</li> <li>• <code>both</code>: to monitor both transmitting and receiving packets.</li> </ul>
<b>Defaults</b>	none
<b>Command Modes</b>	MONITOR SESSION (conf-mon-sess-session-ID)
<b>Supported Modes</b>	All Modes

<b>Command History</b>	<table border="0"> <thead> <tr> <th style="text-align: left;">Version</th> <th style="text-align: left;">Description</th> </tr> </thead> <tbody> <tr> <td>8.3.17.0</td> <td>Supported on the M I/O Aggregator.</td> </tr> </tbody> </table>	Version	Description	8.3.17.0	Supported on the M I/O Aggregator.
Version	Description				
8.3.17.0	Supported on the M I/O Aggregator.				
<b>Example</b>	<pre>Dell(conf-mon-sess-11)#source tengig 10/0 destination tengig 10/47 direction rx Dell(conf-mon-sess-11)#</pre>				
<b>Usage Information</b>	The monitored (source) interface must be a server-facing interface in the format slot/port, where valid slot numbers are 0-1 and server-facing port numbers are from 1 to 32.				

# Quality of Service (QoS)

The Dell Networking operating software commands for quality of service (QoS) include traffic conditioning and congestion control. QoS commands are not universally supported on all Dell Networking Products.

## Topics:

- [Per-Port QoS Commands](#)
- [Policy-Based QoS Commands](#)
- [bandwidth-percentage](#)
- [description](#)
- [dot1p-priority](#)
- [policy-aggregate](#)
- [policy-map-output](#)
- [qos-policy-output](#)
- [rate-shape](#)
- [service-class bandwidth-percentage](#)
- [service-class dot1p-mapping](#)
- [service-class dynamic dot1p](#)
- [service-policy output](#)
- [service-queue](#)
- [show qos dcb-map](#)
- [show qos dot1p-queue-mapping](#)
- [show qos qos-policy-output](#)

## Per-Port QoS Commands

Per-port QoS (port-based QoS) allows you to define the QoS configuration on a per-physical-port basis.

## Policy-Based QoS Commands

Policy-based traffic classification is handled with class maps. These maps classify unicast traffic into one of four classes. The system allows you to match multiple class maps and specify multiple match criteria. Policy-based QoS is not supported on logical interfaces, such as port-channels, VLANs, or Loopbacks.

## bandwidth-percentage

Assign a percentage of weight to the class/queue.

**Syntax** `bandwidth-percentage percentage`

To remove the bandwidth percentage, use the `no bandwidth-percentage` command.

**Parameters** `percentage` Enter the percentage assignment of weight to the class/queue. The range is from 1 to 100% (granularity 1%).

**Defaults** none

**Command Modes** CONFIGURATION (conf-qos-policy-out)

**Supported Modes** Programmable-Mux (PMUX)

<b>Command History</b>	<table border="0"> <tr> <td><b>Version</b></td> <td><b>Description</b></td> </tr> <tr> <td><b>9.9(0.0)</b></td> <td>Introduced on the FN IOM.</td> </tr> <tr> <td><b>9.4(0.0)</b></td> <td>Supported on the FN I/O Aggregator.</td> </tr> <tr> <td><b>9.2(0.0)</b></td> <td>Introduced on the M I/O Aggregator.</td> </tr> <tr> <td><b>8.3.16.1</b></td> <td>Introduced on the MXL 10/40GbE Switch IO Module.</td> </tr> </table>	<b>Version</b>	<b>Description</b>	<b>9.9(0.0)</b>	Introduced on the FN IOM.	<b>9.4(0.0)</b>	Supported on the FN I/O Aggregator.	<b>9.2(0.0)</b>	Introduced on the M I/O Aggregator.	<b>8.3.16.1</b>	Introduced on the MXL 10/40GbE Switch IO Module.
<b>Version</b>	<b>Description</b>										
<b>9.9(0.0)</b>	Introduced on the FN IOM.										
<b>9.4(0.0)</b>	Supported on the FN I/O Aggregator.										
<b>9.2(0.0)</b>	Introduced on the M I/O Aggregator.										
<b>8.3.16.1</b>	Introduced on the MXL 10/40GbE Switch IO Module.										
<b>Usage Information</b>	The unit of bandwidth percentage is 1%. A bandwidth percentage of 0 is allowed and disables the scheduling of that class. If the sum of the bandwidth percentages given to all eight classes exceeds 100%, the bandwidth percentage automatically scales down to 100%.										
<b>Related Commands</b>	<a href="#">qos-policy-output</a> — creates a QoS output policy.										

## description

Add a description to the selected policy map or QoS policy.

<b>Syntax</b>	<code>description {description}</code> To remove the description, use the <code>no description {description}</code> command.										
<b>Parameters</b>	<b>description</b> Enter a description to identify the policies (80 characters maximum).										
<b>Defaults</b>	none										
<b>Command Modes</b>	CONFIGURATION (policy-map-input and policy-map-output; conf-qos-policy-in and conf-qos-policy-out; wred)										
<b>Supported Modes</b>	Programmable-Mux (PMUX)										
<b>Command History</b>	<table border="0"> <tr> <td><b>Version</b></td> <td><b>Description</b></td> </tr> <tr> <td><b>9.9(0.0)</b></td> <td>Introduced on the FN IOM.</td> </tr> <tr> <td><b>9.4(0.0)</b></td> <td>Supported on the FN I/O Aggregator.</td> </tr> <tr> <td><b>9.2(0.0)</b></td> <td>Introduced on the M I/O Aggregator.</td> </tr> <tr> <td><b>8.3.16.1</b></td> <td>Introduced on the MXL 10/40GbE Switch IO Module.</td> </tr> </table>	<b>Version</b>	<b>Description</b>	<b>9.9(0.0)</b>	Introduced on the FN IOM.	<b>9.4(0.0)</b>	Supported on the FN I/O Aggregator.	<b>9.2(0.0)</b>	Introduced on the M I/O Aggregator.	<b>8.3.16.1</b>	Introduced on the MXL 10/40GbE Switch IO Module.
<b>Version</b>	<b>Description</b>										
<b>9.9(0.0)</b>	Introduced on the FN IOM.										
<b>9.4(0.0)</b>	Supported on the FN I/O Aggregator.										
<b>9.2(0.0)</b>	Introduced on the M I/O Aggregator.										
<b>8.3.16.1</b>	Introduced on the MXL 10/40GbE Switch IO Module.										
<b>Related Commands</b>	<a href="#">policy-map-output</a> — creates an output policy map. <a href="#">qos-policy-output</a> — creates an output QoS-policy on the router.										

## dot1p-priority

Assign a value to the IEEE 802.1p bits on the traffic this interface receives.

<b>Syntax</b>	<code>dot1p-priority priority-value</code> To delete the IEEE 802.1p configuration on the interface, use the <code>no dot1p-priority</code> command.								
<b>Parameters</b>	<b>priority-value</b> Enter a value from 0 to 7.								
	<table border="0"> <thead> <tr> <th>dot1p</th> <th>Queue Number</th> </tr> </thead> <tbody> <tr> <td><b>0</b></td> <td>2</td> </tr> <tr> <td><b>1</b></td> <td>0</td> </tr> <tr> <td><b>2</b></td> <td>1</td> </tr> </tbody> </table>	dot1p	Queue Number	<b>0</b>	2	<b>1</b>	0	<b>2</b>	1
dot1p	Queue Number								
<b>0</b>	2								
<b>1</b>	0								
<b>2</b>	1								

<b>dot1p</b>	<b>Queue Number</b>
<b>3</b>	3
<b>4</b>	4
<b>5</b>	5
<b>6</b>	6
<b>7</b>	7

**Defaults** none

**Command Modes** INTERFACE

**Supported Modes** Programmable-Mux (PMUX)

<b>Command History</b>	<b>Version</b>	<b>Description</b>
	<b>9.9(0.0)</b>	Introduced on the FN IOM.
	<b>9.4(0.0)</b>	Supported on the FN I/O Aggregator.
	<b>9.2(0.0)</b>	Introduced on the M I/O Aggregator.
	<b>8.3.16.1</b>	Introduced on the MXL 10/40GbE Switch IO Module.

**Usage Information** The `dot1p-priority` command changes the priority of incoming traffic on the interface. The system places traffic marked with a priority in the correct queue and processes that traffic according to its queue.

When you set the priority for a port channel, the physical interfaces assigned to the port channel are configured with the same value. You cannot assign the `dot1p-priority` command to individual interfaces in a port channel.

## policy-aggregate

Allow an aggregate method of configuring per-port QoS via policy maps. An aggregate QoS policy is part of the policy map (input/output) applied on an interface.

**Syntax** `policy-aggregate qos-policy-name`  
To remove a policy aggregate configuration, use the `no policy-aggregate qos-policy-name` command.

**Parameters** ***qos-policy-name*** Enter the name of the policy map in character format (32 characters maximum).

**Defaults** none

**Command Modes** CONFIGURATION (policy-map-input and policy-map-output)

**Supported Modes** Programmable-Mux (PMUX)

<b>Command History</b>	<b>Version</b>	<b>Description</b>
	<b>9.9(0.0)</b>	Introduced on the FN IOM.
	<b>9.4(0.0)</b>	Supported on the FN I/O Aggregator.
	<b>9.2(0.0)</b>	Introduced on the M I/O Aggregator.
	<b>8.3.16.1</b>	Introduced on the MXL 10/40GbE Switch IO Module.

**Usage Information** Aggregate input/output QoS policy applies to all the port ingoing/outgoing traffic. Aggregate input/output QoS policy can coexist with per queue input/output QoS policies.

1. If only aggregate input QoS policy exists, input traffic conditioning configurations (rate-police) apply. Any marking configurations in aggregate input QoS policy are ignored.
2. If aggregate input QoS policy and per class input QoS policy coexist, aggregate input QoS policy preempts per class input QoS policy on input traffic conditioning (rate-police). In other words, if rate police configuration exists in the aggregate QoS policy, the rate police configurations in per class QoS are ignored. Marking configurations in per class input QoS policy still apply to each queue.

**Related Commands** [policy-map-output](#) — creates an output policy map.

## policy-map-output

Create an output policy map.

**Syntax** `policy-map-output policy-map-name`  
 To remove a policy map, use the `no policy-map-output policy-map-name` command.

**Parameters** ***policy-map-name*** Enter the name for the policy map in character format (32 characters maximum).

**Defaults** none

**Command Modes** CONFIGURATION

**Supported Modes** Programmable-Mux (PMUX)

Command History	Version	Description
	<b>9.9(0.0)</b>	Introduced on the FN IOM.
	<b>9.4(0.0)</b>	Supported on the FN I/O Aggregator.
	<b>9.2(0.0)</b>	Introduced on the M I/O Aggregator.
	<b>8.3.16.1</b>	Introduced on the MXL 10/40GbE Switch IO Module.

**Usage Information** To assign traffic to different flows using QoS policy, use the Output Policy map. This command enables Policy-Map-Output Configuration mode (`conf-policy-map-out`).

**Related Commands** [service-queue](#) — assigns a class map and QoS policy to different queues.  
[policy-aggregate](#) — allows an aggregate method of configuring per-port QoS using policy maps.  
[service-policy output](#) — applies an output policy map to the selected interface.

## qos-policy-output

Create a QoS output policy.

**Syntax** `qos-policy-output qos-policy-name`  
 To remove an existing output QoS policy, use the `no qos-policy-output qos-policy-name` command.

**Parameters** ***qos-policy-name*** Enter your output QoS policy name in character format (32 characters maximum).

**Defaults** none

**Command Modes** CONFIGURATION

**Supported Modes** Programmable-Mux (PMUX)

Command History	Version	Description
	<b>9.9(0.0)</b>	Introduced on the FN IOM.

Version	Description
9.4(0.0)	Supported on the FN I/O Aggregator.
9.2(0.0)	Introduced on the M I/O Aggregator.
8.3.16.1	Introduced on the MXL 10/40GbE Switch IO Module.

#### Usage Information

To specify the name of the output QoS policy, use this command. After the output policy is specified, rate-limit, bandwidth-percentage, and WRED can be defined. This command enables Qos-Policy-Output Configuration mode — (conf-qos-policy-out).

#### Related Commands

[bandwidth-percentage](#) — assigns weight to the class/queue percentage.

## rate-shape

Shape the traffic output on the selected interface.

**Syntax** `rate shape [kbps] rate [burst-KB]`

#### Parameters

<b>kbps</b>	Enter the keyword <code>kbps</code> to specify the rate limit in Kilobits per second (Kbps). Make the following value a multiple of 64. The range is from 0 to 40000000. The default granularity is Megabits per second (Mbps).
<b>rate</b>	Enter the outgoing rate in multiples of 10 Mbps. The range is from 10 to 10000.
<b>burst-KB</b>	(OPTIONAL) Enter the burst size in KB. The range is from 0 to 10000. The default is <b>50</b> .

**Defaults** Granularity for rate is **Mbps** unless you use the `kbps` option.

**Command Modes** QOS-POLICY-OUT

**Supported Modes** Programmable-Mux (PMUX)

#### Command History

Version	Description
9.9(0.0)	Introduced on the FN IOM.
9.4(0.0)	Supported on the FN I/O Aggregator.
9.2(0.0)	Introduced on the M I/O Aggregator.
8.3.16.1	Introduced on the MXL 10/40GbE Switch IO Module.

#### Usage Information

When you apply `rate-shape` in QoS policy both on the Queue Level and in Aggregate mode, the queue-based shaping occurs first then aggregate rate shaping.

## service-class bandwidth-percentage

Specify a minimum bandwidth for queues.

**Syntax** `service-class bandwidth-percentage queue0 number queue1 number queue2 number queue3 number`

#### Parameters

**number** Enter the bandwidth-weight, as a percentage. The range is from 1 to 100.

**Defaults** none

**Command Modes** CONFIGURATION

**Supported Modes** Programmable-Mux (PMUX)



<b>Command History</b>	<table border="0"> <thead> <tr> <th style="text-align: left;"><b>Version</b></th> <th style="text-align: left;"><b>Description</b></th> </tr> </thead> <tbody> <tr> <td><b>9.9(0.0)</b></td> <td>Introduced on the FN IOM.</td> </tr> <tr> <td><b>9.4(0.0)</b></td> <td>Supported on the FN I/O Aggregator.</td> </tr> <tr> <td><b>9.2(0.0)</b></td> <td>Introduced on the M I/O Aggregator.</td> </tr> <tr> <td><b>8.3.16.1</b></td> <td>Introduced on the MXL 10/40GbE Switch IO Module.</td> </tr> </tbody> </table>	<b>Version</b>	<b>Description</b>	<b>9.9(0.0)</b>	Introduced on the FN IOM.	<b>9.4(0.0)</b>	Supported on the FN I/O Aggregator.	<b>9.2(0.0)</b>	Introduced on the M I/O Aggregator.	<b>8.3.16.1</b>	Introduced on the MXL 10/40GbE Switch IO Module.
<b>Version</b>	<b>Description</b>										
<b>9.9(0.0)</b>	Introduced on the FN IOM.										
<b>9.4(0.0)</b>	Supported on the FN I/O Aggregator.										
<b>9.2(0.0)</b>	Introduced on the M I/O Aggregator.										
<b>8.3.16.1</b>	Introduced on the MXL 10/40GbE Switch IO Module.										
<b>Usage Information</b>	<p>Guarantee a minimum bandwidth to different queues globally using the <code>service-class bandwidth-percentage</code> command from CONFIGURATION mode. The command is applied in the same way as the <code>bandwidth-percentage</code> command in an output QoS policy. The <code>bandwidth-percentage</code> command in QOS-POLICY-OUT mode supersedes the <code>service-class bandwidth-percentage</code> command.</p> <p>When you enable ETS, the egress QoS features in the output QoS policy-map (such as <code>service-class bandwidth-percentage</code> and <code>bandwidth-percentage</code>), the default bandwidth allocation ratio for egress queues are superseded by ETS configurations. This is to provide compatibility with DCBX. Therefore, Dell Networking OS recommends disabling ETS when you wish to apply these features exclusively. After you disable ETS on an interface, the configured parameters are applied.</p>										

## service-class dot1p-mapping

Configure a service-class criterion based on a dot1p value.

<b>Syntax</b>	<code>service-class dot1p-mapping {dot1p0 value   dot1p1 value   dot1p2 queue   dot1p3 value   dot1p4 value  dot1p5 value   dot1p6 value   dot1p7 value}</code>								
<b>Parameters</b>	<table border="0"> <tr> <td style="vertical-align: top;"><b>value</b></td> <td>Enter a dot1p list number and value. The list number range is from 0 to 7. The range is from 0 to 3.</td> </tr> </table>	<b>value</b>	Enter a dot1p list number and value. The list number range is from 0 to 7. The range is from 0 to 3.						
<b>value</b>	Enter a dot1p list number and value. The list number range is from 0 to 7. The range is from 0 to 3.								
<b>Defaults</b>	<p>For each dot1p Priority, the default CoS queue value is:</p> <ul style="list-style-type: none"> <li>• dot1p CoS Queue <ul style="list-style-type: none"> <li>0 0-7</li> <li>1 0-7</li> <li>2 0-7</li> <li>3 0-7</li> <li>4 0-7</li> <li>5 0-7</li> <li>6 0-7</li> <li>7 0-7</li> </ul> </li> </ul>								
<b>Command Modes</b>	CONFIGURATION								
<b>Supported Modes</b>	Programmable-Mux (PMUX)								
<b>Command History</b>	<table border="0"> <thead> <tr> <th style="text-align: left;"><b>Version</b></th> <th style="text-align: left;"><b>Description</b></th> </tr> </thead> <tbody> <tr> <td><b>9.9(0.0)</b></td> <td>Introduced on the FN IOM.</td> </tr> <tr> <td><b>9.4(0.0)</b></td> <td>Supported on the FN I/O Aggregator.</td> </tr> <tr> <td><b>8.3.17.0</b></td> <td>Supported on the M I/O Aggregator.</td> </tr> </tbody> </table>	<b>Version</b>	<b>Description</b>	<b>9.9(0.0)</b>	Introduced on the FN IOM.	<b>9.4(0.0)</b>	Supported on the FN I/O Aggregator.	<b>8.3.17.0</b>	Supported on the M I/O Aggregator.
<b>Version</b>	<b>Description</b>								
<b>9.9(0.0)</b>	Introduced on the FN IOM.								
<b>9.4(0.0)</b>	Supported on the FN I/O Aggregator.								
<b>8.3.17.0</b>	Supported on the M I/O Aggregator.								
<b>Usage Information</b>	To apply dot1p-queue-mapping, use the <code>service-class dynamic dot1p</code> command.								

# service-class dynamic dot1p

Honor all 802.1p markings on incoming switched traffic on an interface (from INTERFACE mode) or on all interfaces (from CONFIGURATION mode). A CONFIGURATION mode entry supersedes an INTERFACE mode entry.

**Syntax** `service-class dynamic dot1p`  
To return to the default setting, use the `no service-class dynamic dot1p` command.

**Defaults** All dot1p traffic is mapped to Queue 0 unless you enable the `service-class dynamic dot1p` command. The default mapping is as follows:

dot1p	Queue ID
0	0
1	0
2	0
3	1
4	2
5	3
6	3
7	3

**Command Modes**

- INTERFACE
- CONFIGURATION

**Supported Modes** Programmable-Mux (PMUX)

**Command History**

Version	Description
9.9(0.0)	Introduced on the FN IOM.
9.4(0.0)	Supported on the FN I/O Aggregator.
9.2(0.0)	Introduced on the M I/O Aggregator.
8.3.16.1	Introduced on the MXL 10/40GbE Switch IO Module.

**Usage Information**

To honor all incoming 802.1p markings on incoming switched traffic on the interface, enter this command. By default, this facility is not enabled (that is, the 802.1p markings on incoming traffic are not honored).

You can apply this command on both physical interfaces and port channels. When you set the `service-class dynamic` for a port channel, the physical interfaces assigned to the port channel are automatically configured; you cannot assign the `service-class dynamic` command to individual interfaces in a port channel.

- All dot1p traffic is mapped to Queue 0 unless you enable the `service-class dynamic dot1p` command on an interface or globally.
- Layer 2 or Layer 3 service policies supersede dot1p service classes.

# service-policy output

Apply an output policy map to the selected interface.

**Syntax** `service-policy output policy-map-name`  
To remove the output policy map from the interface, use the `no service-policy output policy-map-name` command.

**Parameters** *policy-map-name* Enter the name for the policy map in character format (16 characters maximum). You can identify an existing policy map or name one that does not yet exist.

**Defaults** none  
**Command Modes** INTERFACE  
**Supported Modes** Programmable-Mux (PMUX)

<b>Command History</b>	<b>Version</b>	<b>Description</b>
	<b>9.9(0.0)</b>	Introduced on the FN IOM.
	<b>9.4(0.0)</b>	Supported on the FN I/O Aggregator.
	<b>9.2(0.0)</b>	Introduced on the M I/O Aggregator.
	<b>8.3.16.1</b>	Introduced on the MXL 10/40GbE Switch IO Module.

**Usage Information** A single policy-map can be attached to one or more interfaces to specify the service-policy for those interfaces. A policy map attached to an interface can be modified.

**Related Commands** [policy-map-output](#) — creates an output policy map.

## service-queue

Assign a class map and QoS policy to different queues.

**Syntax** `service-queue queue-id [class-map class-map-name] [qos-policy qos-policy-name]`

To remove the queue assignment, use the `no service-queue queue-id [class-map class-map-name] [qos-policy qos-policy-name]` command.

<b>Parameters</b>		
<b>queue-id</b>		Enter the value used to identify a queue. The range is from 0 to 3 (four queues per interface; four queues are reserved for control traffic).
<b>class-map class-map-name</b>	(OPTIONAL)	Enter the keyword <code>class-map</code> then the class map name assigned to the queue in character format (32 character maximum).  <b>NOTE:</b> This option is available under <code>policy-map-input</code> only.
<b>qos-policy qos-policy-name</b>	(OPTIONAL)	Enter the keywords <code>qos-policy</code> then the QoS policy name assigned to the queue in text format (32 characters maximum). This specifies the input QoS policy assigned to the queue under <code>policy-map-input</code> and output QoS policy under <code>policy-map-output</code> context.

**Defaults** none  
**Command Modes** CONFIGURATION (conf-policy-map-in and conf-policy-map-out)  
**Supported Modes** Programmable-Mux (PMUX)

<b>Command History</b>	<b>Version</b>	<b>Description</b>
	<b>9.9(0.0)</b>	Introduced on the FN IOM.
	<b>9.4(0.0)</b>	Supported on the FN I/O Aggregator.
	<b>9.2(0.0)</b>	Introduced on the M I/O Aggregator.
	<b>8.3.16.1</b>	Introduced on the MXL 10/40GbE Switch IO Module.

**Usage Information** This command assigns a class map or QoS policy to different queues.

**Related Commands** [service-policy output](#) — applies an output policy map to the selected interface.

# show qos dcb-map

Display the DCB parameters configured in a specified DCB map.

**Syntax** `show qos dcb-map map-name`

**Parameters** *map-name* Displays the PFC and ETS parameters configured in the specified map.

**Command Modes**

- EXEC
- EXEC Privilege

**Supported Modes** All Modes

Command History	Version	Description
	9.9(0.0)	Introduced on the FN IOM.
	9.6(0.0)	Supported on the FN I/O Aggregator and M I/O Aggregator.

**Usage Information** Use the `show qos dcb-map` command to display the enhanced transmission selection (ETS) and priority-based flow control (PFC) parameters used to configure server-facing Ethernet ports.

The following table describes the `show qos dcb-map` output shown in the example below.

Field	Description
State	Complete: All mandatory DCB parameters are correctly configured. In progress: The DCB map configuration is not complete. Some mandatory parameters are not configured.
PFC Mode	PFC configuration in DCB map: On (enabled) or Off.
PG	Priority group configured in the DCB map.
TSA	Transmission scheduling algorithm used by the priority group: Enhanced Transmission Selection (ETS).
BW	Percentage of bandwidth allocated to the priority group.
PFC	PFC setting for the priority group: On (enabled) or Off.
Priorities	802.1p priorities configured in the priority group.

## Example

```
Dell# show qos dcb-map dcbmap2

State      :Complete
PfcMode:ON
-----
PG:0 TSA:ETS BW:50 PFC:OFF
Priorities:0 1 2 4 5 6 7

PG:1 TSA:ETS BW:50 PFC:ON
Priorities:3
```

# show qos dot1p-queue-mapping

View dot1p to queue mapping.

**Syntax** `show qos dot1p-queue-mapping`

**Defaults** none

**Command Modes**

- EXEC
- EXEC Privilege

Command History	Version	Description
	<b>9.9(0.0)</b>	Introduced on the FN IOM.
	<b>9.4(0.0)</b>	Supported on the FN I/O Aggregator.
	<b>8.3.17.0</b>	Supported on the M I/O Aggregator.

#### Example

```
Dell#show qos dot1p-queue-mapping
Dot1p Priority : 0 1 2 3 4 5 6 7
               Queue : 0 0 0 1 2 3 3 3
Dell#
```

## show qos qos-policy-output

View the output QoS policy details.

**Syntax** `show qos qos-policy-output [qos-policy-name]`

**Parameters** **qos-policy-name** Enter the QoS policy name.

**Defaults** none

**Command Modes**

- EXEC
- EXEC Privilege

**Supported Modes** Programmable-Mux (PMUX)

Command History	Version	Description
	<b>9.9(0.0)</b>	Introduced on the FN IOM.
	<b>9.4(0.0)</b>	Supported on the FN I/O Aggregator.
	<b>9.2(0.0)</b>	Introduced on the M I/O Aggregator.
	<b>8.3.16.1</b>	Introduced on the MXL 10/40GbE Switch IO Module.

#### Example

```
Dell#show qos qos-policy-output

Qos-policy-output qmap_out
Bandwidth-percentage 10
Qos-policy-output qmap_wg
Rate-shape 100 50
Wred yellow wy
Wred green wg
Dell#
```

## Security

This chapter describes various types of security commands in the Dell Networking OS, in the following sections:

The commands are listed in the following sections:

- [AAA Accounting Commands](#)
- [Authentication and Password Commands](#)
- [RADIUS Commands](#)
- [TACACS+ Commands](#)
- [SSH Server and SCP Commands](#)

**NOTE:** Starting with the Dell Networking OS version 7.2.1.0, LEAP with MSCHAP v2 supplicant is implemented.

### Topics:

- [AAA Accounting Commands](#)
- [Authentication and Password Commands](#)
- [RADIUS Commands](#)
- [Suppressing AAA Accounting for Null Username Sessions](#)
- [TACACS+ Commands](#)
- [SSH Server and SCP Commands](#)
- [ICMP Commands](#)

## AAA Accounting Commands

AAA Accounting enables tracking of services that users are accessing and the amount of network resources being consumed by those services. When you enable AAA Accounting, the network server reports user activity to the TACACS+ security server in the form of accounting records. Each accounting record is comprised of accounting AV pairs and is stored on the access control server.

As with authentication and authorization, you must configure AAA Accounting by defining a named list of accounting methods, and then applying that list to various interfaces.

### aaa accounting

Enable AAA Accounting and create a record for monitoring the accounting function.

**Syntax**            `aaa accounting {system | exec | commands level} {name | default}{start-stop | wait-start | stop-only} {tacacs+}`

To disable AAA Accounting, use the `no aaa accounting {system | exec | command level} {name | default}{start-stop | wait-start | stop-only} {tacacs+} command`.

#### Parameters

- |                              |   |
|------------------------------|---|
| <b>system</b>                | Enter the keyword <code>system</code> to send accounting information of any other AAA configuration.  |
| <b>exec</b>                  | Enter the keyword <code>exec</code> to send accounting information when a user has logged in to EXEC mode.  |
| <b>commands <i>level</i></b> | Enter the keyword <code>command</code> then a privilege level for accounting of commands executed at that privilege level.  |
| <b><i>name</i>   default</b> | Enter one of the following: <ul style="list-style-type: none"> <li>• For <code>name</code>, enter a user-defined name of a list of accounting methods.</li> <li>• For <code>default</code>, the default accounting methods used.</li> </ul> |

<b>start-stop</b>	Enter the keywords <code>start-stop</code> to send a “start accounting” notice at the beginning of the requested event and a “stop accounting” notice at the end of the event.
<b>wait-start</b>	Enter the keywords <code>wait-start</code> to ensure that the TACACS+ security server acknowledges the start notice before granting the user’s process request.
<b>stop-only</b>	Enter the keywords <code>stop-only</code> to instruct the TACACS+ security server to send a “stop record accounting” notice at the end of the requested user process.
<b>tacacs+</b>	Enter the keyword <code>tacacs+</code> to use TACACS+ data for accounting. Dell Networking OS currently only supports TACACS+ accounting.

**Defaults** none  
**Command Modes** CONFIGURATION  
**Supported Modes** All Modes

Command History	Version	Description
	<b>9.9(0.0)</b>	Introduced on the FN IOM.
	<b>9.4(0.0)</b>	Supported on the FN I/O Aggregator and M I/O Aggregator.

**Usage Information** In the example above, TACACS+ accounting is used to track all usage of EXEC command and commands on privilege level 15.  
Privilege level 15 is the default. If you want to track usage at privilege level 1 for example, use the `aaa accounting command 1 command`.

**Example**

```
Dell(conf)# aaa accounting exec default start-stop tacacs+
Dell(conf)# aaa accounting command 15 default start-stop tacacs+
Dell(config)#
```

**Related Commands** [enable password](#) — changes the password for the `enable` command.

## aaa accounting suppress

Prevent the generation of accounting records of users with the user name value of NULL.

**Syntax** `aaa accounting suppress null-username`  
To permit accounting records to users with user name value of NULL, use the `no aaa accounting suppress null-username` command.

**Defaults** Accounting records are recorded for all users.

**Command Modes** CONFIGURATION

**Supported Modes** All Modes

Command History	Version	Description
	<b>9.9(0.0)</b>	Introduced on the FN IOM.
	<b>9.4(0.0)</b>	Supported on the FN I/O Aggregator and M I/O Aggregator.

**Usage Information** Dell Networking OS issues accounting records for all users on the system, including users whose username string, due to protocol translation, is NULL. For example, a user who comes on line with the `aaa authentication login method-list none` command is applied. To prevent the accounting records from being generated for sessions that do not have user names associated to them, use the `aaa accounting suppress` command.

## aaa authorization commands

Set parameters that restrict (or permit) a user's access to EXEC and CONFIGURATION level commands.

**Syntax** `aaa authorization commands {level | role role-name}{name|default} {local | tacacs+ | none}`

Undo a configuration with the `no aaa authorization commands {level | role role-name} {name|default} {local | tacacs+ | none} command`.

<b>Parameters</b>	<b>commands level</b>	Enter the keyword <code>commands</code> then the command privilege level for command level authorization.
	<b>role role-name</b>	Enter the keyword <code>role</code> then the role name.
	<b>name</b>	Define a name for the list of authorization methods.
	<b>default</b>	Define the default list of authorization methods.
	<b>local</b>	Use the authorization parameters on the system to perform authorization.
	<b>tacacs+</b>	Use the TACACS+ protocol to perform authorization.
	<b>none</b>	Enter the keyword <code>none</code> to apply no authorization.

**Defaults** none

**Command Modes** CONFIGURATION

**Supported Modes** All Modes

**Command History** This guide is platform-specific. For command information about other platforms, refer to the relevant *Dell Networking OS Command Line Reference Guide*.

The following is a list of the Dell Networking OS version history for this command.

Version	Description
9.6(0.0)	Supported on the M I/O Aggregator

## aaa authorization config-commands

Set parameters that restrict (or permit) a user's access to EXEC level commands.

**Syntax** `aaa authorization config-commands`  
Disable authorization checking for CONFIGURATION level commands using the `no aaa authorization config-commands` command.

**Defaults** Enabled when you configure `aaa authorization commands` command.

**Command Modes** CONFIGURATION

**Supported Modes** All Modes

**Command History** This guide is platform-specific. For command information about other platforms, refer to the relevant *Dell Networking OS Command Line Reference Guide*.

The following table lists the Dell Networking OS version history for this command.

Version	Description
9.9(0.0)	Introduced on the FN IOM.
9.6.(0.0)	Supported on the FN I/O Aggregator and M I/O Aggregator.

**Usage Information** By default, the `aaa authorization commands` command configures the system to check both EXEC level and CONFIGURATION level commands. Use the command `no aaa authorization config-commands` to enable only EXEC-level command checking.



## aaa authorization exec

Set parameters that restrict (or permit) a user's access to EXEC-level commands.

<b>Syntax</b>	<code>aaa authorization exec {name   default} {local    tacacs+    if-authenticated    none}</code>  To disable authorization checking for EXEC level commands, use the <code>no aaa authorization exec</code> command.										
<b>Parameters</b>	<table><tr><td><b>name</b></td><td>Define a name for the list of authorization methods.</td></tr><tr><td><b>default</b></td><td>Define the default list of authorization methods.</td></tr><tr><td><b>local</b></td><td>Use the authorization parameters on the system to perform authorization.</td></tr><tr><td><b>tacacs+</b></td><td>Use the TACACS+ protocol to perform authorization.</td></tr><tr><td><b>none</b></td><td>Enter the keyword <code>none</code> to apply no authorization.</td></tr></table>	<b>name</b>	Define a name for the list of authorization methods.	<b>default</b>	Define the default list of authorization methods.	<b>local</b>	Use the authorization parameters on the system to perform authorization.	<b>tacacs+</b>	Use the TACACS+ protocol to perform authorization.	<b>none</b>	Enter the keyword <code>none</code> to apply no authorization.
<b>name</b>	Define a name for the list of authorization methods.										
<b>default</b>	Define the default list of authorization methods.										
<b>local</b>	Use the authorization parameters on the system to perform authorization.										
<b>tacacs+</b>	Use the TACACS+ protocol to perform authorization.										
<b>none</b>	Enter the keyword <code>none</code> to apply no authorization.										
<b>Defaults</b>	none										
<b>Command Modes</b>	CONFIGURATION										
<b>Supported Modes</b>	All Modes										
<b>Command History</b>	This guide is platform-specific. For command information about other platforms, refer to the relevant <i>Dell Networking OS Command Line Reference Guide</i> .										

The following table lists the Dell Networking OS version history for this command.

Version	Description
9.9(0.0)	Introduced on the FN IOM.
9.6.(0.0)	Supported on the FN I/O Aggregator and M I/O Aggregator.

## accounting

Apply an accounting method list to terminal lines.

<b>Syntax</b>	<code>accounting {exec   commands {level   role role-name} method-list}</code>						
<b>Parameters</b>	<table><tr><td><b>exec</b></td><td>Enter the keyword <code>exec</code> to apply an EXEC level accounting method list.</td></tr><tr><td><b>commands {level   role role-name}</b></td><td>Enter the keywords <code>commands level</code> to apply an EXEC and CONFIGURATION level accounting method list or enter the keywords <code>commands role</code> and then the role name for accounting of commands run by a user with that role.</td></tr><tr><td><b>method-list</b></td><td>Enter a method list that you defined using the <code>aaa accounting exec</code> or <code>aaa accounting commands</code>.</td></tr></table>	<b>exec</b>	Enter the keyword <code>exec</code> to apply an EXEC level accounting method list.	<b>commands {level   role role-name}</b>	Enter the keywords <code>commands level</code> to apply an EXEC and CONFIGURATION level accounting method list or enter the keywords <code>commands role</code> and then the role name for accounting of commands run by a user with that role.	<b>method-list</b>	Enter a method list that you defined using the <code>aaa accounting exec</code> or <code>aaa accounting commands</code> .
<b>exec</b>	Enter the keyword <code>exec</code> to apply an EXEC level accounting method list.						
<b>commands {level   role role-name}</b>	Enter the keywords <code>commands level</code> to apply an EXEC and CONFIGURATION level accounting method list or enter the keywords <code>commands role</code> and then the role name for accounting of commands run by a user with that role.						
<b>method-list</b>	Enter a method list that you defined using the <code>aaa accounting exec</code> or <code>aaa accounting commands</code> .						
<b>Defaults</b>	none						
<b>Command Modes</b>	LINE						
<b>Supported Modes</b>	All Modes						
<b>Command History</b>	<table><thead><tr><th>Version</th><th>Description</th></tr></thead><tbody><tr><td>9.9(0.0)</td><td>Introduced on the FN IOM.</td></tr><tr><td>9.4(0.0)</td><td>Supported on the FN I/O Aggregator and M I/O Aggregator.</td></tr></tbody></table>	Version	Description	9.9(0.0)	Introduced on the FN IOM.	9.4(0.0)	Supported on the FN I/O Aggregator and M I/O Aggregator.
Version	Description						
9.9(0.0)	Introduced on the FN IOM.						
9.4(0.0)	Supported on the FN I/O Aggregator and M I/O Aggregator.						
<b>Related Commands</b>	<a href="#">aaa accounting</a> — enables AAA Accounting and creates a record for monitoring the accounting function.						

**Example** The following example configures accounting for the role `secadmin` using default method:

```
Dell(conf-vty-0)# accounting commands role secadmin default
```

## show accounting

Display the active accounting sessions for each online user.

**Syntax** `show accounting`

**Defaults** `none`

**Command Modes** EXEC

**Supported Modes** All Modes

**Command History** This guide is platform-specific. For command information about other platforms, refer to the relevant *Dell Networking OS Command Line Reference Guide*.

The following table lists the Dell Networking OS version history for this command.

Version	Description
9.4(0.0)	Introduced on the M I/O Aggregator.

**Usage Information** This command steps through all active sessions and then displays the accounting records for the active account functions.

### Example

```
Dell#show accounting
Active accounted actions on tty2, User admin Priv 1 Role <none>
  Task ID 2, EXEC Accounting record, 00:02:03 Elapsed, service=shell
Active accounted actions on tty3, User ad Priv 15 Role <none>
  Task ID 7, EXEC Accounting record, 00:01:22 Elapsed, service=shell
Active accounted actions on tty4, User ad Priv 15 Role <none>
  Task ID 11, EXEC Accounting record, 00:00:35 Elapsed, service=shell
Active accounted actions on tty5, User ad1 Priv1 Role sysadmin
  Task ID 16, EXEC Accounting record, 00:00:04 Elapsed, service=shell
Dell#
```

**Related Commands** [aaa accounting](#) — enables AAA Accounting and creates a record for monitoring the accounting function.

# Authentication and Password Commands

This section contains the commands that control the management access to the system.

## aaa authentication enable

Configure AAA Authentication method lists for user access to EXEC privilege mode (the “Enable” access).

**Syntax** `aaa authentication enable {default | method-list-name} method [... method2]`

To return to the default setting, use the `no aaa authentication enable {default | method-list-name} method [... method2]` command.

### Parameters

<b>default</b>	Enter the keyword <code>default</code> then the authentication methods to use as the default sequence of methods for the Enable login. The default is <code>default enable</code> .
<b>method-list-name</b>	Enter a text string (up to 16 characters long) to name the list of enabled authentication methods activated at login.
<b>method</b>	Enter one of the following methods:

- `enable`: use the password the `enable password` command defines in CONFIGURATION mode.
- `line`: use the password the `password` command defines in LINE mode.
- `none`: no authentication.
- `radius`: use the RADIUS servers configured with the `radius-server host` command.
- `tacacs+`: use the TACACS+ server(s) configured with the `tacacs-server host` command.

**... method2** (OPTIONAL) In the event of a “no response” from the first method, Dell Networking Operating System (OS) applies the next configured method.

**Defaults** Use the `enable password`.

**Command Modes** CONFIGURATION

**Supported Modes** All Modes

**Command History**

Version	Description
9.9(0.0)	Introduced on the FN IOM.
9.4(0.0)	Supported on the FN I/O Aggregator.
9.3(0.0)	Supported on the M I/O Aggregator.

**Usage Information**

By default, the `Enable password` is used. If you configure `aaa authentication enable default`, Dell Networking Operating System (OS) uses the methods defined for `Enable access` instead.

Methods configured with the `aaa authentication enable` command are evaluated in the order they are configured. If authentication fails using the primary method, Dell Networking Operating System (OS) employs the second method (or third method, if necessary) automatically. For example, if the TACACS+ server is reachable, but the server key is invalid, Dell Networking OS proceeds to the next authentication method. The TACACS+ is incorrect, but the user is still authenticated by the secondary method.

**Related Commands**

- [enable password](#) — changes the password for the `enable` command.
- [login authentication](#) — enables AAA login authentication on the terminal lines.
- [radius-server host](#) — specifies a RADIUS server host.
- [tacacs-server host](#) — specifies a TACACS+ server host.

## aaa authentication login

Configure AAA Authentication method lists for user access to EXEC mode (`Enable log-in`).

**Syntax**

```
aaa authentication login {method-list-name | default} method [... method4]
```

To return to the default setting, use the `no aaa authentication login {method-list-name | default}` command.

**Parameters**

- method-list-name** Enter a text string (up to 16 characters long) as the name of a user-configured method list that can be applied to different lines.
- default** Enter the keyword `default` to specify that the method list specified is the default method for all terminal lines.
- method** Enter one of the following methods:
  - `enable`: use the password the `enable password` command defines in CONFIGURATION mode.
  - `line`: use the password the `password` command defines in LINE mode.
  - `none`: no authentication.

- `radius`: use the RADIUS servers configured with the `radius-server host` command.
- `tacacs+`: use the TACACS+ servers configured with the `tacacs-server host` command.

... *method4* (OPTIONAL) Enter up to four additional methods. In the event of a “no response” from the first method, Dell Networking Operating System (OS) applies the next configured method (up to four configured methods).

**Defaults** Not configured (that is, no authentication is performed).

**Command Modes** CONFIGURATION

**Supported Modes** All Modes

Command History	Version	Description
	<b>9.11(0.0)</b>	Included a prompt to force the users to re-authenticate, when re-authentication is enabled.
	<b>9.9(0.0)</b>	Introduced on the FN IOM.
	<b>9.4(0.0)</b>	Supported on the FN I/O Aggregator.
	<b>9.3(0.0)</b>	Supported on the M I/O Aggregator.

**Usage Information** By default, the locally configured username password is used. If you configure `aaa authentication login default`, Dell Networking Operating System (OS) uses the methods this command defines for login instead.

Methods configured with the `aaa authentication login` command are evaluated in the order they are configured. If users encounter an error with the first method listed, Dell Networking Operating System (OS) applies the next method configured. If users fail the first method listed, no other methods are applied. The only exception is the local method. If the user’s name is not listed in the local database, the next method is applied. If the correct user name/password combination is not entered, the user is not allowed access to the switch.

**NOTE:** If authentication fails using the primary method, Dell Networking Operating System (OS) employs the second method (or third method, if necessary) automatically. For example, if the TACACS+ server is reachable, but the server key is invalid, Dell Networking Operating System (OS) proceeds to the next authentication method. The TACACS+ is incorrect, but the user is still authenticated by the secondary method.

After configuring the `aaa authentication login` command, configure the `login authentication` command to enable the authentication scheme on terminal lines.

Connections to the SSH server work with the following login mechanisms: local, radius, and tacacs.

**Related Commands**

- [login authentication](#) — enables AAA login authentication on the terminal lines.
- [radius-server host](#) — specifies a RADIUS server host.
- [tacacs-server host](#) — specifies a TACACS+ server host.

## aaa reauthenticate enable

Enable re-authentication of user whenever there is a change in the authenticators.

**Syntax** `aaa reauthenticate enable`

To disable the re-authentication option, use the `no aaa reauthenticate enable` command.

**Defaults** Disabled

**Command Modes** CONFIGURATION

**Command History**

This guide is platform-specific. For command information about other platforms, see the relevant *Dell EMC Networking OS Command Line Reference Guide*.

Version	Description
---------	-------------

9.11(0.0)	Introduced this command.
-----------	--------------------------

**Usage Information**

When an operating system enables to change the user authenticators, the users might access resources and perform tasks that they do not have authorization.

Once re-authentication is enabled, Dell EMC Networking OS prompts the users to re-authenticate whenever there is a change in authenticators.

The change in authentication happens when:

- Add or remove an authentication server (RADIUS/TACACS+)
- Modify an AAA authentication/authorization list
- Change to role-only (RBAC) mode

The re-authentication is also applicable for authenticated 802.1x devices. When there is a change in the authentication servers, the supplicants connected to all the ports are forced to re-authenticate.

**Example**

```
DellEMC(config)#aaa reauthenticate enable
```

```
DellEMC(config)#aaa authentication login vty_auth_list radius  
Force all logged-in users to re-authenticate (y/n)?
```

```
DellEMC(config)#radius-server host 192.100.0.12  
Force all logged-in users to re-authenticate (y/n)?
```

## banner exec

Configure a message that is displayed when you enter EXEC mode.

**Syntax** `banner exec c line c`

To delete a banner, use the `no banner exec` command.

**Parameters**

**c** Enter the keywords `banner exec`, then enter a character delineator, represented here by the letter `c`. Press **ENTER**.

**line** Enter a text string for your banner message ending the message with your delineator. In the following example, the delineator is a percent character (%); the banner message is "testing, testing".

**Defaults** No banner is displayed.

**Command Modes** CONFIGURATION

**Supported Modes** All Modes

**Command History**

Version	Description
---------	-------------

9.9(0.0)	Introduced on the FN IOM.
----------	---------------------------

9.4(0.0)	Supported on the FN I/O Aggregator.
----------	-------------------------------------

9.3(0.0)	Supported on the M I/O Aggregator.
----------	------------------------------------

**Usage Information**

After entering the banner login command, type one or more spaces and a delineator character. Enter the banner text then the second delineator character. When the user is connected to the router, if a message of the day banner is configured, it displays first. If no message of the day banner is configured, the login banner and prompt appear. After the user has logged in, the EXEC banner (if configured) displays.

## Example

```
Dell(conf)#banner exec ?
LINE c banner-text c, where 'c' is a delimiting character
Dell(conf)#banner exec %
Enter TEXT message. End with the character '%'.
This is the banner%
Dell(conf)#end
Dell#exit
4d21h5m: %RPM0-P:CP %SEC-5-LOGOUT: Exec session is terminated for user
on line
console

This is the banner

Dell con0 now available

Press RETURN to get started.
4d21h6m: %RPM0-P:CP %SEC-5-LOGIN_SUCCESS: Login successful for user on
line
console
This is the banner
Dell>
```

## Related Commands

- [banner login](#) — sets a banner for login connections to the system.
- [exec-banner](#) — enables the display of a text string when you enter EXEC mode.
- [line](#) — enables and configures the console and virtual terminal lines to the system.

## banner login

Set a banner to display when logging on to the system.

**Syntax** `banner login {keyboard-interactive | no keyboard-interactive} [c line c]`

Parameters		
<b>keyboard-interactive</b>		Enter the keyword <code>keyboard-interactive</code> to require a carriage return (CR) to get the message banner prompt.
<b>c</b>		Enter a delineator character to specify the limits of the text banner. The delineator is a percent character (%).
<b>line</b>		Enter a text string for your text banner message ending the message with your delineator. The delineator is a percent character (%). Range: maximum of 50 lines, up to 255 characters per line

**Defaults** No banner is configured and the CR is required when creating a banner.

**Command Modes** CONFIGURATION

**Supported Modes** All Modes

Command History	Version	Description
	<b>9.9(0.0)</b>	Introduced on the FN IOM.
	<b>9.4(0.0)</b>	Supported on the FN I/O Aggregator.
	<b>9.3(0.0)</b>	Supported on the M I/O Aggregator.

**Usage Information** After entering the `banner login` command, type one or more spaces and a delineator character. Enter the banner text then the second delineator character. When the user is connected to the router, if a message of the day banner is configured, it displays first. If no message of the day banner is configured, the login banner and prompt appear. After the user has logged in, the EXEC banner (if configured) displays.

## Example

```
Dell(conf)#banner login ?
keyboard-interactive Press enter key to get prompt
LINE c banner-text c, where 'c' is a delimiting character
Dell(conf)#no banner login ?
```

```

keyboard-interactive Prompt will be displayed by default
<cr>
Dell(conf)#banner login keyboard-interactive

Enter TEXT message. End with the character '%'.
This is the banner%
Dell(conf)#end
Dell#exit

13d21h9m: %RPM0-P:CP %SEC-5-LOGOUT: Exec session is terminated for user
on line console

This is the banner

Dell con0 now available

Press RETURN to get started.
13d21h10m: %RPM0-P:CP %SEC-5-LOGIN_SUCCESS: Login successful for user on
line console
This is the banner
Dell>

```

**Related Commands** [exec-banner](#) — enables the display of a text string when you enter EXEC mode.

## banner motd

Set a message of the day (MOTD) banner.

**Syntax** `banner motd c line c`

**Parameters**

- c*** Enter a delineator character to specify the limits of the text banner. The delineator is a percent character (%).
- line*** Enter a text string for your MOTD banner the message with your delineator. The delineator is a percent character (%).

**Defaults** No banner is configured.

**Command Modes** CONFIGURATION

**Supported Modes** All Modes

Command History	Version	Description
	<b>9.9(0.0)</b>	Introduced on the FN IOM.
	<b>9.4(0.0)</b>	Supported on the FN I/O Aggregator.
	<b>9.3(0.0)</b>	Supported on the M I/O Aggregator.

**Usage Information** After entering the banner login command, type one or more spaces and a delineator character. Enter the banner text then the second delineator character. When the user is connected to the router, if a message of the day banner is configured, it displays first. If no message of the day banner is configured, the login banner and prompt appear. After the user has logged in, the EXEC banner (if configured) displays.

**Related Commands** [banner exec](#) — enables the display of a text string when you enter EXEC mode.  
[banner login](#) — sets a banner to display after successful login to the system.

## debug radius

View RADIUS transactions to assist with troubleshooting.

**Syntax** `debug radius`

To disable debugging of RADIUS, use the `no debug radius` command.

**Defaults** Disabled.  
**Command Modes** EXEC Privilege  
**Supported Modes** All Modes

Command History	Version	Description
	<b>9.9(0.0)</b>	Introduced on the FN IOM.
	<b>9.4(0.0)</b>	Supported on the FN I/O Aggregator.
	<b>9.3(0.0)</b>	Supported on the M I/O Aggregator.

## debug tacacs+

To assist with troubleshooting, view TACACS+ transactions.

**Syntax** `debug tacacs+`  
To disable debugging of TACACS+, use the `no debug tacacs+` command.

**Defaults** Disabled.  
**Command Modes** EXEC Privilege  
**Supported Modes** All Modes

Command History	Version	Description
	<b>9.9(0.0)</b>	Introduced on the FN IOM.
	<b>9.4(0.0)</b>	Supported on the FN I/O Aggregator.
	<b>9.3(0.0)</b>	Supported on the M I/O Aggregator.

## exec-banner

Enable the display of a text string when the user enters EXEC mode.

**Syntax** `exec-banner`  
To disable the banner on terminal lines, use the `no exec-banner` command.

**Defaults** **Enabled on all lines** (if configured, the banner appears).  
**Command Modes** LINE  
**Supported Modes** All Modes

Command History	Version	Description
	<b>9.9(0.0)</b>	Introduced on the FN IOM.
	<b>9.4(0.0)</b>	Supported on the FN I/O Aggregator.
	<b>9.3(0.0)</b>	Supported on the M I/O Aggregator.

**Usage Information** Optionally, use the `banner exec` command to create a text string that is displayed when you access EXEC mode. This command toggles that display.

**Related Commands** [banner exec](#)— configures a banner to display when entering EXEC mode.  
[line](#) — enables and configures console and virtual terminal lines to the system.



## ip radius source-interface

Specify an interface's IP address as the source IP address for RADIUS connections.

**Syntax** `ip radius source-interface interface`

To delete a source interface, use the `no ip radius source-interface` command.

**Parameters**

***interface***

Enter the following keywords and slot/port or number information:

- For a 100/1000 Ethernet interface, enter the keyword `GigabitEthernet` then the slot/port information.
- For a Gigabit Ethernet interface, enter the keyword `GigabitEthernet` then the slot/port information.
- For Loopback interfaces, enter the keyword `loopback` then a number from zero (0) to 16838.
- For the Null interface, enter the keywords `null 0`.
- For a Port Channel interface, enter the keywords `port-channel` then a number. The range is from 1 to 128.
- For a ten-Gigabit Ethernet interface, enter the keyword `TenGigabitEthernet` then the slot/port information.
- For a 40-Gigabit Ethernet interface, enter the keyword `fortyGigE` then the slot/port information.
- For VLAN interface, enter the keyword `vlan` then a number from 1 to 4094.

**Defaults** Not configured.

**Command Modes** CONFIGURATION

**Supported Modes** All Modes

**Command History**

**Version**

**9.3.(0.0)**

**Description**

Supported on the M I/O Aggregator.

## ip tacacs source-interface

Specify an interface's IP address as the source IP address for TACACS+ connections.

**Syntax** `ip tacacs source-interface interface`

To delete a source interface, use the `no ip tacacs source-interface` command.

**Parameters**

***interface***

Enter the following keywords and slot/port or number information:

- For a 100/1000 Ethernet interface, enter the keyword `GigabitEthernet` then the slot/port information.
- For a Gigabit Ethernet interface, enter the keyword `GigabitEthernet` then the slot/port information.
- For Loopback interfaces, enter the keyword `loopback` then a number from zero (0) to 16838.
- For the Null interface, enter the keywords `null 0`.
- For a Port Channel interface, enter the keywords `port-channel` then a number. The range is from 1 to 128.
- For a ten-Gigabit Ethernet interface, enter the keyword `TenGigabitEthernet` then the slot/port information.
- For a 40-Gigabit Ethernet interface, enter the keyword `fortyGigE` then the slot/port information.
- For VLAN interface, enter the keyword `vlan` then a number from 1 to 4094.

**Defaults** Not configured.

**Command Modes** CONFIGURATION

**Supported Modes** All Modes

<b>Command History</b>	<b>Version</b>	<b>Description</b>
	<b>9.3.(0.0)</b>	Supported on the M I/O Aggregator.

## login authentication

To designate the terminal lines, apply an authentication method list.

**Syntax** `login authentication {method-list-name | default}`  
To use the local user/password database for login authentication, use the `no login authentication` command.

**Parameters**

<b><i>method-list-name</i></b>	Enter the keywords <code>method-list-name</code> to specify that method list, created in the <code>aaa authentication login</code> command, to be applied to the designated terminal line.
<b>default</b>	Enter the keyword <code>default</code> to specify that the default method list, created in the <code>aaa authentication login</code> command, is applied to the terminal line.

**Defaults** No authentication is performed on the console lines. Local authentication is performed on the virtual terminal and auxiliary lines.

**Command Modes** LINE

**Supported Modes** All Modes

<b>Command History</b>	<b>Version</b>	<b>Description</b>
	<b>9.9(0.0)</b>	Introduced on the FN IOM.
	<b>9.4(0.0)</b>	Supported on the FN I/O Aggregator.
	<b>9.3(0.0)</b>	Supported on the M I/O Aggregator.

**Usage Information** If you configure the `aaa authentication login default` command, the `login authentication default` command automatically is applied to all terminal lines.

**Related Commands** [aaa authentication login](#) — selects the login authentication methods.

## secure-cli enable

Enable the secured CLI mode.

**Syntax** `secure-cli enable`

**Command Modes** CONFIGURATION

**Command History** This guide is platform-specific. For command information about other platforms, see the relevant *Dell EMC Networking OS Command Line Reference Guide*.

<b>Version</b>	<b>Description</b>
<b>9.11(0.0)</b>	Introduced this command.

**Usage Information** The secured CLI mode prevents the users from enhancing the permissions or promoting the privilege levels. After entering the command, save the running-configuration.  
Once you save the running-configuration, the secured CLI mode is enabled. If you do not want to enter the secured mode, do not save the running-configuration.

Once saved, to disable the secured CLI mode, you need to manually edit the startup-configuration file and reboot the system.

## RADIUS Commands

The following RADIUS commands are supported by Dell Networking Operating System (OS).

### radius-server deadline

Configure a time interval during which non-responsive RADIUS servers to authentication requests are skipped.

<b>Syntax</b>	<code>radius-server deadline seconds</code>	
	To disable this function or return to the default value, use the <code>no radius-server deadline</code> command.	
<b>Parameters</b>	<b>seconds</b>	Enter a number of seconds during which non-responsive RADIUS servers are skipped. The range is from 0 to 2147483647 seconds. The default is <b>0 seconds</b> .
<b>Defaults</b>	<b>0 seconds</b>	
<b>Command Modes</b>	CONFIGURATION	
<b>Supported Modes</b>	All Modes	
<b>Command History</b>	<b>Version</b>	<b>Description</b>
	<b>9.9(0.0)</b>	Introduced on the FN IOM.
	<b>9.4(0.0)</b>	Supported on the FN I/O Aggregator.
	<b>9.3(0.0)</b>	Supported on the M I/O Aggregator.

### radius-server host

Configure a RADIUS server host.

<b>Syntax</b>	<code>radius-server host {hostname   ipv4-address   ipv6-address} [auth-port port-number] [retransmit retries] [timeout seconds] [key [encryption-type] key]</code>	
<b>Parameters</b>	<b>hostname</b>	Enter the name of the RADIUS server host.
	<b>ipv4-address   ipv6-address</b>	Enter the IPv4 address (A.B.C.D) or IPv6 address (X:X:X::X) of the RADIUS server host.
	<b>auth-port port-number</b>	(OPTIONAL) Enter the keywords <code>auth-port</code> then a number as the port number. The range is from zero (0) to 65535. The default port-number is <b>1812</b> .
	<b>retransmit retries</b>	(OPTIONAL) Enter the keyword <code>retransmit</code> then a number as the number of attempts. This parameter overwrites the <code>radius-server retransmit</code> command. The range is from zero (0) to 100. The default is <b>3 attempts</b> .
	<b>timeout seconds</b>	(OPTIONAL) Enter the keyword <code>timeout</code> then the seconds the time interval the switch waits for a reply from the RADIUS server. This parameter overwrites the <code>radius-server timeout</code> command. The range is from 0 to 1000. The default is <b>5 seconds</b> .
	<b>key [encryption-type] key</b>	(OPTIONAL) Enter the keyword <code>key</code> then an optional encryption-type and a string up to 42 characters long as the authentication key. The RADIUS host server uses this authentication key and the RADIUS daemon operating on this switch.

For the encryption-type, enter either zero (0) or 7 as the encryption type for the key entered. The options are:

- 0 is the default and means the password is not encrypted and stored as clear text.
- 7 means that the password is encrypted and hidden.

Configure this parameter last because leading spaces are ignored.

**Defaults** Not configured.

**Command Modes** CONFIGURATION

**Supported Modes** All Modes

<b>Command History</b>	<b>Version</b>	<b>Description</b>
	<b>9.9(0.0)</b>	Introduced on the FN IOM.
	<b>9.4(0.0)</b>	Supported on the FN I/O Aggregator.
	<b>9.3(0.0)</b>	Supported on the M I/O Aggregator.

**Usage Information** To configure any number of RADIUS server hosts for each server host that is configured, use this command. Dell Networking Operating System (OS) searches for the RADIUS hosts in the order they are configured in the software.

The global default values for the `timeout`, `retransmit`, and `key` optional parameters are applied, unless those values are specified in the `radius-server host` or other commands. To return to the global default values, if you configure the `timeout`, `retransmit`, or `key` values, include those keywords when using the `no radius-server host` command syntax.

**Related Commands** [login authentication](#) — sets the database to be checked when a user logs in.

[radius-server retransmit](#) — sets the number of times the RADIUS server attempts to send information.

[radius-server timeout](#) — sets the time interval before the RADIUS server times out.

## radius-server key

Configure a key for all RADIUS communications between the switch and the RADIUS host server.

**Syntax** `radius-server key [encryption-type] key`

To delete a password, use the `no radius-server key` command.

**Parameters** **encryption-type** (OPTIONAL) Enter either zero (0) or 7 as the encryption type for the key entered. The options are:

- 0 is the default and means the key is not encrypted and stored as clear text.
- 7 means that the key is encrypted and hidden.

**key** Enter a string that is the key to be exchanged between the switch and RADIUS servers. It can be up to 42 characters long.

**Defaults** Not configured.

**Command Modes** CONFIGURATION

**Supported Modes** All Modes

<b>Command History</b>	<b>Version</b>	<b>Description</b>
	<b>9.9(0.0)</b>	Introduced on the FN IOM.
	<b>9.4(0.0)</b>	Supported on the FN I/O Aggregator.
	<b>9.3(0.0)</b>	Supported on the M I/O Aggregator.

<b>Usage Information</b>	The key configured on the switch must match the key configured on the RADIUS server daemon. If you configure the <code>key</code> parameter in the <code>radius-server host</code> command, the key configured with the <code>radius-server key</code> command is the default key for all RADIUS communications.
<b>Related Commands</b>	<a href="#">radius-server host</a> — configures a RADIUS host.

## radius-server retransmit

Configure the number of times the switch attempts to connect with the configured RADIUS host server before declaring the RADIUS host server unreachable.

<b>Syntax</b>	<code>radius-server retransmit <i>retries</i></code> To configure zero retransmit attempts, use the <code>no radius-server retransmit</code> command. To return to the default setting, use the <code>radius-server retransmit 3</code> command.								
<b>Parameters</b>	<b><i>retries</i></b> Enter a number of attempts that Dell Networking Operating System (OS) tries to locate a RADIUS server. The range is from zero (0) to 100. The default is <b>3 retries</b> .								
<b>Defaults</b>	<b>3 retries</b>								
<b>Command Modes</b>	CONFIGURATION								
<b>Supported Modes</b>	All Modes								
<b>Command History</b>	<table> <thead> <tr> <th>Version</th> <th>Description</th> </tr> </thead> <tbody> <tr> <td><b>9.9(0.0)</b></td> <td>Introduced on the FN IOM.</td> </tr> <tr> <td><b>9.4(0.0)</b></td> <td>Supported on the FN I/O Aggregator.</td> </tr> <tr> <td><b>9.3(0.0)</b></td> <td>Supported on the M I/O Aggregator.</td> </tr> </tbody> </table>	Version	Description	<b>9.9(0.0)</b>	Introduced on the FN IOM.	<b>9.4(0.0)</b>	Supported on the FN I/O Aggregator.	<b>9.3(0.0)</b>	Supported on the M I/O Aggregator.
Version	Description								
<b>9.9(0.0)</b>	Introduced on the FN IOM.								
<b>9.4(0.0)</b>	Supported on the FN I/O Aggregator.								
<b>9.3(0.0)</b>	Supported on the M I/O Aggregator.								
<b>Related Commands</b>	<a href="#">radius-server host</a> — configures a RADIUS host.								

## radius-server timeout

To reply to a request, configure the amount of time the RADIUS client (the switch) waits for a RADIUS host server .

<b>Syntax</b>	<code>radius-server timeout <i>seconds</i></code> To return to the default value, use the <code>no radius-server timeout</code> command.								
<b>Parameters</b>	<b><i>seconds</i></b> Enter the number of seconds between an unsuccessful attempt and the radius-server timeout times out. The range is from zero (0) to 1000 seconds. The default is <b>5 seconds</b> .								
<b>Defaults</b>	<b>5 seconds</b>								
<b>Command Modes</b>	CONFIGURATION								
<b>Supported Modes</b>	All Modes								
<b>Command History</b>	<table> <thead> <tr> <th>Version</th> <th>Description</th> </tr> </thead> <tbody> <tr> <td><b>9.9(0.0)</b></td> <td>Introduced on the FN IOM.</td> </tr> <tr> <td><b>9.4(0.0)</b></td> <td>Supported on the FN I/O Aggregator.</td> </tr> <tr> <td><b>9.3(0.0)</b></td> <td>Supported on the M I/O Aggregator.</td> </tr> </tbody> </table>	Version	Description	<b>9.9(0.0)</b>	Introduced on the FN IOM.	<b>9.4(0.0)</b>	Supported on the FN I/O Aggregator.	<b>9.3(0.0)</b>	Supported on the M I/O Aggregator.
Version	Description								
<b>9.9(0.0)</b>	Introduced on the FN IOM.								
<b>9.4(0.0)</b>	Supported on the FN I/O Aggregator.								
<b>9.3(0.0)</b>	Supported on the M I/O Aggregator.								

**Related Commands**      [radius-server host](#) — configures a RADIUS host.

## show privilege

View your access level.

**Syntax**                    `show privilege`

**Command Modes**      • EXEC  
                             • EXEC Privilege

**Supported Modes** All Modes

**Command History**

Version	Description
<b>9.9(0.0)</b>	Introduced on the FN IOM.
<b>9.4(0.0)</b>	Supported on the FN I/O Aggregator.
<b>9.3(0.0)</b>	Supported on the M I/O Aggregator.

**Example**

```
Dell#show privilege
Current privilege level is 15
Dell#
```

## Suppressing AAA Accounting for Null Username Sessions

When you activate AAA accounting, the Dell Networking OS software issues accounting records for all users on the system, including users whose username string, because of protocol translation, is NULL.

An example of this is a user who comes in on a line where the AAA authentication `login method-list none` command is applied. To prevent accounting records from being generated for sessions that do not have usernames associated with them, use the following command.

- Prevent accounting records from being generated for users whose username string is NULL.

```
CONFIGURATION mode
aaa accounting suppress null-username
```

## TACACS+ Commands

Dell Networking OS supports TACACS+ as an alternate method for login authentication.

### TACACS+ Accounting

Enable AAA Accounting and create a record for monitoring the accounting function.

**Syntax**                    `aaa accounting {system | exec | commands level} {name | default}{start-stop | wait-start | stop-only} {tacacs+}`

To disable AAA Accounting, use the `no aaa accounting {system | exec | command level} {name | default}{start-stop | wait-start | stop-only} {tacacs+} command`

**Parameters**

**system**                    *Enter the keyword system to send accounting information of any other AAA configuration.*

<b>exec</b>	Enter the keyword <code>exec</code> to send accounting information when a user has logged in to EXEC mode.
<b>commands level</b>	Enter the keyword <code>command</code> then a privilege level for accounting of commands executed at that privilege level.
<b>name   default</b>	Enter one of the following: <ul style="list-style-type: none"> <li>For name, enter a user-defined name of a list of accounting methods.</li> <li>For default, the default accounting methods used.</li> </ul>
<b>start-stop</b>	Enter the keywords <code>start-stop</code> to send a “start accounting” notice at the beginning of the requested event and a “stop accounting” notice at the end of the event.
<b>wait-start</b>	Enter the keywords <code>wait-start</code> to ensure that the TACACS+ security server acknowledges the start notice before granting the user’s process request.
<b>stop-only</b>	Enter the keywords <code>stop-only</code> to instruct the TACACS+ security server to send a “stop record accounting” notice at the end of the requested user process.
<b>tacacs+</b>	Enter the keyword <code>tacacs+</code> to use TACACS+ data for accounting.

Dell Networking OS currently only supports TACACS+ accounting.

**Defaults** None

**Command Modes** CONFIGURATION

**Usage Information** In the example above, TACACS+ accounting is used to track all usage of EXEC command and commands on privilege level 15. Privilege level 15 is the default. If you want to track usage at privilege level 1 for example, use `theaaa accounting command 1 command`.

**Supported Modes** All Modes

**Command History**

Version	Description
<b>9.9(0.0)</b>	Introduced on the FN IOM.
<b>9.5(0.0)</b>	Supported on the FN I/O Agregator and M I/O Agregator.

**Example**

```
Dell(config)# aaa accounting exec default start-stop tacacs+
Dell(config)# aaa accounting command 15 default start-stop tacacs+
Dell(config)#
```

**Related Commands**

<b>enable password</b>	changes the password for the enable command.
<b>login authentication</b>	enables AAA login authentication on the terminal lines.
<b>password</b>	creates a password.
<b>tacacs-server host</b>	specifies a TACACS+ server host.

## tacacs-server host

Specify a TACACS+ host.

**Syntax** `tacacs-server host {hostname | ipv4-address | ipv6-address} [port number] [timeout seconds] [key key]`

**Parameters**

<b>hostname</b>	Enter the name of the TACACS+ server host.
<b>ipv4-address   ipv6-address</b>	Enter the IPv4 address (A.B.C.D) or IPv6 address (X:X:X::X) of the TACACS+ server host.

**port number** (OPTIONAL) Enter the keyword `port` then a number as the port to be used by the TACACS+ server. The range is from zero (0) to 65535. The default is **49**.

**timeout seconds** (OPTIONAL) Enter the keyword `timeout` then the number of seconds the switch waits for a reply from the TACACS+ server. The range is from 0 to 1000. The default is **10 seconds**.

**key key** (OPTIONAL) Enter the keyword `key` then a string up to 42 characters long as the authentication key. This authentication key must match the key specified in the `tacacs-server key` for the TACACS+ daemon.

**Defaults** Not configured.

**Command Modes** CONFIGURATION

**Supported Modes** All Modes

Command History	Version	Description
	<b>9.9(0.0)</b>	Introduced on the FN IOM.
	<b>9.4(0.0)</b>	Supported on the FN I/O Aggregator.
	<b>9.3(0.0)</b>	Supported on the M I/O Aggregator.

**Usage Information** To list multiple TACACS+ servers to be used by the `aaa authentication login` command, configure this command multiple times.

If you are not configuring the switch as a TACACS+ server, you do not need to configure the `port`, `timeout` and `key` optional parameters. If you do not configure a key, the key assigned in the `tacacs-server key` command is used.

**Related Commands** [aaa authentication login](#) — specifies the login authentication method.  
[tacacs-server key](#) — configures a TACACS+ key for the TACACS server.

## tacacs-server key

Configure a key for communication between a TACACS+ server and a client.

**Syntax** `tacacs-server key [encryption-type] key`

To delete a key, use the `no tacacs-server key key` command.

**Parameters**

**encryption-type** (OPTIONAL) Enter either zero (0) or 7 as the encryption type for the key entered. The options are:

- 0 is the default and means the key is not encrypted and stored as clear text.
- 7 means that the key is encrypted and hidden.

**key** Enter a text string, up to 42 characters long, as the clear text password. Leading spaces are ignored.

**Defaults** Not configured.

**Command Modes** CONFIGURATION

**Supported Modes** All Modes

Command History	Version	Description
	<b>9.9(0.0)</b>	Introduced on the FN IOM.
	<b>9.4(0.0)</b>	Supported on the FN I/O Aggregator.
	<b>9.3(0.0)</b>	Supported on the M I/O Aggregator.



**Usage Information** The key configured with this command must match the key configured on the TACACS+ daemon.

## timeout login response

Specify how long the software waits for the login input (for example, the user name and password) before timing out.

**Syntax** `timeout login response seconds`

To return to the default values, use the `no timeout login response` command.

**Parameters** **seconds** Enter a number of seconds the software waits before logging you out. The range is:

- VTY: the range is from 1 to 30 seconds, the default is **30 seconds**.
- Console: the range is from 1 to 300 seconds, the default is **0 seconds** (no timeout).
- AUX: the range is from 1 to 300 seconds, the default is **0 seconds** (no timeout).

**Defaults** See the defaults settings shown in *Parameters*.

**Command Modes** LINE

**Supported Modes** All Modes

Command History	Version	Description
	<b>9.9(0.0)</b>	Introduced on the FN IOM.
	<b>9.4(0.0)</b>	Supported on the FN I/O Aggregator.
	<b>9.3(0.0)</b>	Supported on the M I/O Aggregator.

**Usage Information** The software measures the period of inactivity defined in this command as the period between consecutive keystrokes. For example, if your password is "password" you can enter "p" and wait 29 seconds to enter the next letter.

## SSH Server and SCP Commands

The Dell Networking OS supports secure shell (SSH) protocol versions 1.5 and 2.0. SSH is a protocol for secure remote login over an insecure network. SSH sessions are encrypted and use authentication.

### enable password

Change the password for the `enable` command.

**Syntax** `enable password [level level] [encryption-type] password`

To delete a password, use the `no enable password [encryption-type] password [level level]` command.

**Parameters** **level level** (OPTIONAL) Enter the keyword `level` followed by a number as the level of access. The range is from 1 to 15.

**encryption-type** (OPTIONAL) Enter the number 7 or 0 as the encryption type.

Enter a 7 followed by a text string as the hidden password. The text string must be a password that was already encrypted by a Dell Networking router.

Use this parameter only with a password that you copied from the `show running-config` file of another Dell Networking router.

**password** Enter a text string, up to 32 characters long, as the clear text password.

**Defaults** No password is configured. *level* = **15**.

**Command Modes** CONFIGURATION

**Supported Modes** All Modes

Command History	Version	Description
	<b>9.9(0.0)</b>	Introduced on the FN IOM.
	<b>9.4(0.0)</b>	Supported on the FN I/O Aggregator.
	<b>8.3.17.0</b>	Supported on the M I/O Aggregator.

**Usage Information** Use this command to define a password for a level.

Passwords must meet the following criteria:

- Start with a letter, not a number.
- Passwords can have a regular expression as the password. To create a password with a regular expression in it, use CNTL + v prior to entering regular expression. For example, to create the password `abcd]e`, you type "`abcd CNTL v ]e`". When the password is created, you do not use the CNTL + v key combination and enter "`abcd]e`".

 **NOTE:** The question mark (?) is not a supported character.

**Related Commands** [show running-config](#) — views the current configuration.

## enable restricted

Allows Dell Networking technical support to access restricted commands.

**Syntax** `enable restricted [encryption-type] password`

To disallow access to restricted commands, use the `no enable restricted` command.

**Parameters**

***encryption-type*** (OPTIONAL) Enter the number 7 as the encryption type.

Enter 7 followed a text string as the hidden password. The text string must be a password that was already encrypted by a Dell Networking router.

Use this parameter only with a password that you copied from the `show running-config` file of another Dell Networking router.

***password*** Enter a text string, up to 32 characters long, as the clear text password.

**Command Modes** Not configured.

**Supported Modes** All Modes

Command History	Version	Description
	<b>9.9(0.0)</b>	Introduced on the FN IOM.
	<b>9.4(0.0)</b>	Supported on the FN I/O Aggregator.
	<b>8.3.17.0</b>	Supported on the M I/O Aggregator.

**Usage Information** Only Dell Networking Technical Support staff use this command.

## enable sha256-password

Configure SHA-256 based password for the `enable` command.

**Syntax** `enable sha256-password [level level] [encryption-type] password`  
To delete a password, use the `no enable sha256-password [encryption-type] password [level level]` command.

**Parameters**

- sha256-password** Enter the keyword `sha256-password` then the `encryption-type` or the password.
- level *level*** (OPTIONAL) Enter the keyword `level` then a number as the level of access. The range is from 1 to 15.
- encryption-type** (OPTIONAL) Enter the number 8 or 0 as the encryption type.  
Enter 8 to enter the sha256-based hashed password.
- password** Enter a text string, up to 32 characters long, as the clear text password.

**Defaults** No password is configured. *level* = **15**.

**Command Modes** CONFIGURATION

**Command History** This guide is platform-specific. For command information about other platforms, see the relevant *Dell Networking OS Command Line Reference Guide*.

Version	Description
9.10(0.0)	Introduced on the MXL.

**Related Commands**

- [show running-config](#) — views the current configuration.

## service password-encryption

Encrypt all passwords configured in Dell Networking OS.

**Syntax** `service password-encryption`  
To store new passwords as clear text, use the `no service password-encryption` command.

**Defaults** Enabled.

**Command Modes** CONFIGURATION

**Supported Modes** All Modes

Command History	Version	Description
	9.9(0.0)	Introduced on the FN IOM.
	9.4(0.0)	Supported on the FN I/O Aggregator.
	8.3.17.0	Supported on the M I/O Aggregator.

**Usage Information**

 **CAUTION:** Encrypting passwords with this command does not provide a high level of security. When the passwords are encrypted, you cannot return them to plain text unless you re-configure them. To remove an encrypted password, use the `no password password` command.

To keep unauthorized people from viewing passwords in the switch configuration file, use the `service password-encryption` command. This command encrypts the clear-text passwords created for user name passwords, authentication key passwords, the privileged command password, and console and virtual terminal line access passwords.

To view passwords, use the `show running-config` command.

## show ip ssh

Display information about established SSH sessions.

**Syntax** `show ip ssh`

**Command Modes**

- EXEC
- EXEC Privilege

**Supported Modes** All Modes

Command History	Version	Description
	<b>9.10(0.0)</b>	Removed the support for hmac-sha2-256-96 algorithm.
	<b>9.9(0.0)</b>	Introduced on the FN IOM.
	<b>9.4(0.0)</b>	Supported on the FN I/O Aggregator.
	<b>8.3.17.0</b>	Supported on the M I/O Aggregator.

### Example

```
Dell#show ip ssh
SSH server          : enabled.
SSH server version  : v1 and v2.
SSH server vrf      : default.
SSH server ciphers  : 3des-cbc,aes128-cbc,aes192-cbc,aes256-
cbc,aes128-ctr,aes192-ctr,aes256-ctr.
SSH server macs     : hmac-sha2-256, hmac-sha1, hmac-sha1-96,
hmac-md5, hmac-md5-96.
SSH server kex algorithms : diffie-hellman-group-exchange-sha1,diffie-
hellman-group1-sha1,diffie-hellman-group14-sha1.
Password Authentication : enabled.
Hostbased Authentication : disabled.
RSA Authentication    : disabled.
  Vty      Encryption      HMAC      Remote IP
  2        aes128-cbc      hmac-md5  10.16.127.141
  4        aes128-cbc      hmac-md5  10.16.127.141
* 5        aes128-cbc      hmac-md5  10.16.127.141
Dell#
```

**Related Commands** [show ip ssh client-pub-keys](#) — displays the client-public keys.

## show ip ssh client-pub-keys

Displays the client public keys used in host-based authentication

**Syntax** `show ip ssh client-pub-keys`

**Defaults** none

**Command Modes** EXEC

**Supported Modes** All Modes

Command History	Version	Description
	<b>9.9(0.0)</b>	Introduced on the FN IOM.
	<b>9.4(0.0)</b>	Supported on the FN I/O Aggregator.
	<b>8.3.17.0</b>	Supported on the M I/O Aggregator.

**Usage Information**

This command displays the contents of the `flash://ADMIN_DIRssh/knownhosts` file.

**Example**

```
Dell#show ip ssh client-pub-keys

poclab4,123.12.1.123 ssh-rsa AAAAB3NzaC1yc2EAAAABIwAAAIEAox/
QQp8xYhzOxn07yh4VGPAoUfgKoiETHO9G4sNV+ui+DWEc3cgYAcU5Lai1MU20DrzhCwyDNp05tKBU3tRe
o8AxLi6+S4hyEMqHzkzBFNVqHzpQc+Rs4p2urzV0F4pRKnAXdHf3Lk4D460HZRhhVrxqeNxPDpEnWIMPJ
ds= ashwani@poclab4

Dell#
```

## show ip ssh rsa-authentication

Displays the authorized-keys for the RSA authentication.

**Syntax** `show ip ssh rsa-authentication {my-authorized-keys}`

**Parameters** **my-authorized-keys** Display the RSA authorized keys.

**Defaults** none

**Command Modes** EXEC

**Supported Modes** All Modes

Command History	Version	Description
	<b>9.9(0.0)</b>	Introduced on the FN IOM.
	<b>9.4(0.0)</b>	Supported on the FN I/O Aggregator.
	<b>8.3.17.0</b>	Supported on the M I/O Aggregator.

**Usage Information** This command displays the contents of the `flash://ADMIN_DIR/ssh/authorized-keys.username` file.

**Example**

```
Dell#show ip ssh rsa-authentication my-authorized-keys
ssh-rsa
AAAAB3NzaC1yc2EAAAABIwAAAIEAyB1714gFp4r2DRHivMc1VZd0Sg5
GQxRV1y1X1JOMeO6Nd0WuYyZrQMM4qJAoBwtneOXfLBcHF3V2hcMIqa
ZN+CRcnw/zCmlnCf0+qVTdloofsea5r09kS0xTp0CNfHXZ3NuGCq9Ov
33m9+U9tMwhS8vy8AVxdH4x4km3c3t5Jvc=freedom@poclab4
Dell#
```

## show users

Allows you to view information on all users logged in to the switch.

**Syntax** `show users [all]`

**Parameters** **all** (OPTIONAL) Enter the keyword `all` to view all terminal lines in the switch.

**Command Modes** EXEC Privilege

**Supported Modes** All Modes

Command History	Version	Description
	<b>8.3.17.0</b>	Supported on the M I/O Aggregator.

## Usage Information

The following describes the `show user` command shown in the following example.

Field	Description
<b>(untitled)</b>	Indicates with an asterisk (*) which terminal line you are using.
<b>Line</b>	Displays the terminal lines currently in use.
<b>User</b>	Displays the user name of all users logged in.
<b>Host(s)</b>	Displays the terminal line status.
<b>Location</b>	Displays the IP address of the user.

## Example

```
Dell# show users
Authorization Mode: role or privilege
  Line           User           Role           Priv Host(s)
Location
*  0 console 0
  2 vty 0       admin          unassigned     1 idle
10.16.127.35
  3 vty 1       ad             unassigned     15 idle
10.16.127.145
  4 vty 2       ad1            sysadmin       1 idle
10.16.127.141
  5 vty 3       ad1            sysadmin       1 idle
10.16.127.145
  6 vty 4       admin          unassigned     1 idle
10.16.127.141
  7 vty 5       ad             unassigned     15 idle
10.16.127.141
Dell#
```

## Related Commands

`ssh`— enables a user.

# ssh

Open an SSH connection specifying the host name, username, port number and version of the SSH client.

Dell Networking OS supports both inbound and outbound SSH sessions using IPv4 addressing. Inbound SSH supports accessing the system through the management interface as well as through a physical Layer 3 interface.

**Syntax** `ssh {hostname | ipv4 address} [-l username | -p port-number|-v {1|2}]`

### Parameters

<b>hostname</b>	(OPTIONAL) Enter the IP address or the host name of the remote device.
<b>ipv4 address</b>	(OPTIONAL) Enter the IP address in dotted decimal format A.B.C.D.
<b>-l username</b>	(OPTIONAL) Enter the keyword <code>-l</code> followed by the user name used in this SSH session. The default is the user name of the user associated with the terminal.
<b>-p port-number</b>	(OPTIONAL) Enter the keyword <code>-p</code> followed by the port number. The range is from 1 to 65536. The default is <b>22</b> .
<b>-v {1   2}</b>	(OPTIONAL) Enter the keyword <code>-v</code> then the SSH version 1 or 2. The default is the version from the protocol negotiation.

**Defaults** As shown in the *Parameters* section.

**Command Modes** EXEC Privilege

**Supported Modes** All Modes

### Command History

Version	Description
<b>9.10(0.0)</b>	Removed the support for hmac-sha2-256-96 algorithm.
<b>8.3.17.0</b>	Supported on the M I/O Aggregator.

## Example

```
Dell#ssh 10.16.151.48 -l anvltest

Trying 10.16.151.48...
01:18:16: %STKUNIT0-M:CP %SEC-5-SSH_USAGE: Initiated SSH Client v2 (FIPS
Disabled) to anvltest@10.16.151.48 by default from console
anvltest@10.16.151.48's password:
Last login: Thu Jan  5 00:17:47 2012 from login-maa-101
[anvltest@dt-maa-linux-1 ~]# exit
logout
Dell#
```

## username

Establish an authentication system based on user names.

### Syntax

```
username name access-list-name [nopassword | {password | secret | sha256-
password} [encryption-type] password] [privilege level]
```

If you do not want a specific user to enter a password, use the `nopassword` option.

To delete authentication for a user, use the `no username name` command.

### Parameters

<b><i>name</i></b>	Enter a text string for the name of the user up to 63 characters.
<b><i>access-list-name</i></b>	Enter the name of a configured access control list (either an IP access control list or MAC access control list).
<b><i>nopassword</i></b>	Enter the keyword <code>nopassword</code> to specify that the user should not enter a password.
<b><i>password</i></b>	Enter the keyword <code>password</code> followed by the <i>encryption-type</i> or the password.
<b><i>secret</i></b>	Enter the keyword <code>secret</code> followed by the <i>encryption-type</i> or the password.
<b><i>encryption-type</i></b>	Enter an encryption type for the password that you enter. <ul style="list-style-type: none"><li>• 0 directs Dell Networking OS to store the password as clear text. It is the default encryption type when using the <code>password</code> option.</li><li>• 8 to indicate that a password encrypted using a sha256 hashing algorithm follows. This encryption type is available with the <code>sha256-password</code> option only, and is the default encryption type for this option.</li><li>• 7 to indicate that a password encrypted using a DES hashing algorithm follows. This encryption type is available with the <code>password</code> option only.</li><li>• 5 to indicate that a password encrypted using an MD5 hashing algorithm follow. This encryption type is available with the <code>secret</code> option only, and is the default encryption type for this option.</li></ul>
<b><i>password</i></b>	Enter a string up to 32 characters long.
<b><i>privilege level</i></b>	Enter the keyword <code>privilege</code> then a number from zero (0) to 15.
<b><i>secret</i></b>	Enter the keyword <code>secret</code> then the encryption type.
<b><i>sha256-password</i></b>	Enter the keyword <code>sha256-password</code> then the <i>encryption-type</i> or the password.

### Defaults

The default encryption type for the `password` option is **0**. The default encryption type for the `secret` option is **5**. The default encryption type for `sha256-password` option is **8**.

**Command Modes** CONFIGURATION

**Supported Modes** All Modes

Command History	Version	Description
	<b>9.10(0.0)</b>	Added support for the <code>sha256-password</code> option for S3100, S3048-ON, S4048-ON, S4810, S4820T, S5000, S6000, S6000-ON, Z9100-ON, MXL, and Z9500.
	<b>8.3.17.0</b>	Supported on the M I/O Aggregator.
<b>Usage Information</b>	To view the defined user names, use the <code>show running-config user</code> command.	
<b>Related Commands</b>	<a href="#">enable sha256-password</a> — configures SHA-256 based password. <a href="#">service password-encryption</a> — specifies a password for users on terminal lines. <a href="#">show running-config</a> — views the current configuration.	

## ICMP Commands

The internet control message protocol (ICMP) is a network-layer internet protocol that provides message packets to report errors and other information regarding IP packet processing back to the source. Dell Networking OS mainly addresses the following ICMP vulnerabilities:

- ICMP Mask Reply
- ICMP Timestamp Request
- ICMP Replies
- IP ID Values Randomness

Dell Networking OS can be configured to drop ICMP reply messages in the kernel. When the `drop icmp` feature is configured, the system drops the ICMP reply messages on the front end and management interfaces. By default, the Dell Networking OS responds to all the ICMP messages. The Dell Networking OS suppresses the following ICMPv4 and ICMPv6 message types:

**Table 3. Suppressed ICMPv4 message types**

ICMPv4 Message Types
Echo reply (0)
All sub types of destination unreachable (3)
Source quench (4)
Redirect (5)
Router advertisement (9)
Router solicitation (10)
Time exceeded (11)
IP header bad (12)
Timestamp request (13)
Timestamp reply (14)
Information request (15)
Information reply (16)
Address mask request (17)
Address mask reply (18)

 **NOTE:** The Dell Networking OS does not suppress the **ICMPv4** message type `Echo request (8)`.



**Table 4. Suppressed ICMPv6 message types**

ICMPv6 Message Types
Destination unreachable (1)
Time exceeded (3)
IPv6 header bad (4)
Echo reply (129)
Who are you request (139)
Who are you reply (140)
Mtrace response (200)
Mtrace messages (201)

**NOTE:**

The Dell Networking OS does not suppress the following **ICMPv6** message types:

- Packet too big (2)
- Echo request (128)
- Multicast listener query (130)
- Multicast listener report (131)
- Multicast listener done (132)
- Router solicitation (133)
- Router advertisement (134)
- Neighbor solicitation (135)
- Neighbor advertisement (136)
- Redirect (137)
- Router renumbering (138)
- MLD v2 listener report (143)
- Duplicate Address Request (157)
- Duplicate Address Confirmation (158)

## drop icmp

Drops the ICMPv4 and ICMPv6 packets.

**Syntax** `drop {icmp | icmpv6}`

**Command Modes** CONFIGURATION

**Command History** This guide is platform-specific. For command information about other Platforms, see the relevant *Dell Networking OS Command Line Reference Guide*.

Version	Description
9.11.0.0	Introduced on the S4810, S4820T, S3048-ON, S3100 Series, S4048-ON, S5000, S6000, S6000-ON, Z9500, Z9100-ON, S6100-ON, S6010-ON, S4048T-ON, C9000, M IOA, FN IOM, and MXL.

**Usage Information** When the `drop icmp` feature is configured, the system drops the ICMP reply messages on the front end and management interfaces. By default, the Dell Networking OS responds to all the ICMP messages.

**NOTE:** There is no separate CLI to enable IP ID randomness. By default, the IP ID in the kernel is randomized.

# Simple Network Management Protocol (SNMP) and Syslog

This chapter contains commands to configure and monitor the simple network management protocol (SNMP) v1/v2 and Syslog.

## Topics:

- SNMP Commands
- show snmp
- show snmp engineID
- show snmp group
- show snmp supported-mibs
- show snmp supported-traps
- show snmp user
- snmp context
- snmp-server community
- snmp-server context
- snmp-server enable traps
- snmp-server engineID
- snmp-server group
- snmp-server host
- snmp-server user
- snmp-server view

## SNMP Commands

The following SNMP commands are available in the Dell Networking operating software.

The simple network management protocol (SNMP) is used to communicate management information between the network management stations and the agents in the network elements. Dell Networking OS supports SNMP versions 1, 2c, and 3, supporting both read-only and read-write modes. Dell Networking OS sends SNMP traps, which are messages informing an SNMP management system about the network. Dell Networking OS supports up to 16 SNMP trap receivers.

 **NOTE:** The system does not support SNMPv3 traps in PMUX mode.

## Important Points to Remember

- Typically, 5-second timeout and 3-second retry values on an SNMP server are sufficient for both LAN and WAN applications. If you experience a timeout with these values, the recommended best practice on Dell Networking switches (to accommodate their high port density) is to increase the timeout and retry values on your SNMP server to the following:
  - SNMP Timeout — greater than 3 seconds.
  - SNMP Retry count — greater than 2 seconds.
- If you want to query an E-Series switch using SNMP v1/v2/v3 with an IPv6 address, configure the IPv6 address on a non-management port on the switch.
- If you want to send SNMP v1/v2/v3 traps from an E-Series using an IPv6 address, use a non-management port.
- SNMP v3 informs are not currently supported with IPv6 addresses.
- If you are using access control lists (ACLs) in an SNMP v3 configuration, group ACL overrides user ACL if the user is part of that group.
- SNMP operations are not supported on a virtual local area network (VLAN).

# show snmp

Display the status of SNMP network elements.

**Syntax** show snmp

- Command Modes**
- EXEC
  - EXEC Privilege

**Supported Modes** Programmable-Mux (PMUX)

**Command History** This guide is platform-specific. For command information about other platforms, refer to the relevant *Dell Networking OS Command Line Reference Guide*.

The following is a list of the Dell Networking OS version history for this command.

Version	Description
9.9(0.0)	Introduced on the M I/O Aggregator.

## Example

```
45418 SNMP packets input
      0 Bad SNMP version errors
      12 Unknown community name
      0 Illegal operation for community name supplied
      0 Encoding errors
45275 Number of requested variables
      0 Number of altered variables
      76 Get-request PDUs
45265 Get-next PDUs
      0 Set-request PDUs
45406 SNMP packets output
      0 Too big errors (Maximum packet size 1500)
      31 No such name errors
      0 Bad values errors
      0 General errors
45341 Response PDUs
      0 Trap PDUs

Dell#
```

**Related Commands** [snmp—server community](#) — enables the SNMP and set community string.

# show snmp engineID

Display the identification of the local SNMP engine and all remote engines that are configured on the router.

**Syntax** show snmp engineID

- Command Modes**
- EXEC
  - EXEC Privilege

**Supported Modes** Programmable-Mux (PMUX)

**Command History** This guide is platform-specific. For command information about other platforms, refer to the relevant *Dell Networking OS Command Line Reference Guide*.

The following is a list of the Dell Networking OS version history for this command.

Version	Description
9.9(0.0)	Introduced on the M I/O Aggregator.

## Example

```
Dell#show snmp engineID
Local SNMP engineID: 0000178B02000001E80214A8
```

Remote Engine ID	IP-addr	Port
80001F88043132333435	172.31.1.3	5009
80001F88043938373635	172.31.1.3	5008

Dell#

**Related Commands**

[snmp-server engineID](#) — configures local and remote SNMP engines on the router.

## show snmp group

Display the group name, security model, status, and storage type of each group.

**Syntax** `show snmp group`

- Command Modes**
- EXEC
  - EXEC Privilege

**Supported Modes** Programmable-Mux (PMUX)

**Command History** This guide is platform-specific. For command information about other platforms, refer to the relevant *Dell Networking OS Command Line Reference Guide*.

The following is a list of the Dell Networking OS version history for this command.

Version	Description
9.9(0.0)	Introduced on the M I/O Aggregator.

**Usage Information**

The following Example displays a group named *ngroup*. The *ngroup* has a security model of version 3 (v3) with authentication (*auth*), the read and notify name is *nview* with no write view name specified, and finally the row status is active.

**Example**

```
Dell#show snmp group
groupname: v1v2creadg          security model: v1
readview : v1v2cdefault       writeview: no write view
specified                      context: no context
notifyview: v1v2cdefault
specified
row status: active

groupname: v1v2creadg          security model: v2c
readview : v1v2cdefault       writeview: no write view
specified                      context: no context
notifyview: v1v2cdefault
specified
row status: active

groupname: v1v2cwriteg         security model: v1
readview : v1v2cdefault       writeview: v1v2cdefault
notifyview: v1v2cdefault     context: no context
specified
row status: active

groupname: v1v2cwriteg         security model: v2c
readview : v1v2cdefault       writeview: v1v2cdefault
notifyview: v1v2cdefault     context: no context
specified
row status: active

Dell#
```

**Related Commands**

[snmp-server group](#) — configures an SNMP server group.

# show snmp supported-mibs

Display the list of SNMP MIBs supported by the platform.

**Syntax** `show snmp supported-mibs`

- Command Modes**
- EXEC
  - EXEC Privilege

**Command History** This guide is platform-specific. For command information about other platforms, see the relevant *Dell EMC Networking OS Command Line Reference Guide*.

Version	Description
9.14(0.0)	Introduced on the C9010, FN-IOM, MIOA, MXL, S3048-ON, S3100, S4048-ON, S4048T-ON, S5048F-ON, S6000, S6000-ON, S6010-ON, S6100-ON and Z9100-ON.

## Example

```
DellEMC#show snmp supported-mibs
MIB                                OID
-----
RFC1155-SMI                        -
RFC-1212                            -
SNMPv2-SMI                          -
SNMPv2-TC                            -
SNMPv2-CONF                          -
INET-ADDRESS-MIB                    -
IANAifType-MIB                       -
IANA-ADDRESS-FAMILY-NUMBERS-MIB     -
IANA-RTPROTO-MIB                     -
IPV6-FLOW-LABEL-MIB                  -
SNMPv2-MIB                           1.3.6.1.2.1
IF-MIB                               1.3.6.1.2.1.31
IP-MIB                               1.3.6.1.2.1.48
TCP-MIB                              1.3.6.1.2.1.49
UDP-MIB                              1.3.6.1.2.1.50
RFC1213-MIB                          -
EtherLike-MIB                       1.3.6.1.2.1.35
SNMP-FRAMEWORK-MIB                  1.3.6.1.6.3.10
RADIUS-AUTH-CLIENT-MIB              1.3.6.1.2.1.67.1.2
SNMP-MPD-MIB                        1.3.6.1.6.3.11
RMON-MIB                             1.3.6.1.2.1.16
--More--
```

# show snmp supported-traps

Display the list of SNMP traps supported by the platform.

**Syntax** `show snmp supported-traps`

- Command Modes**
- EXEC
  - EXEC Privilege

**Command History** This guide is platform-specific. For command information about other platforms, see the relevant *Dell EMC Networking OS Command Line Reference Guide*.

Version	Description
9.14(0.0)	Introduced on the C9010, FN-IOM, MIOA, MXL, S3048-ON, S3100, S4048-ON, S4048T-ON, S5048F-ON, S6000, S6000-ON, S6010-ON, S6100-ON and Z9100-ON.

## Example

```
DellEMC#show snmp supported-traps
TRAP                                OID
```

```

-----
COLDSTART 1.3.6.1.6.3.1.1.5.1
WARMSTART 1.3.6.1.6.3.1.1.5.2
LINKDOWN 1.3.6.1.6.3.1.1.5.3
LINKUP 1.3.6.1.6.3.1.1.5.4
Authenticationfailure 1.3.6.1.6.3.1.1.5.5
dellNetIfAlarmHighBer 1.3.6.1.4.1.6027.3.11.1.4.1.1
dellNetIfAlarmHighBerClr 1.3.6.1.4.1.6027.3.11.1.4.1.2
dellNetSysAlarmCardDown 1.3.6.1.4.1.6027.3.26.1.5.1.1
dellNetSysAlarmCardUp 1.3.6.1.4.1.6027.3.26.1.5.1.2
dellNetSysAlarmCardOffline 1.3.6.1.4.1.6027.3.26.1.5.1.3
dellNetSysAlarmCardMismatch 1.3.6.1.4.1.6027.3.26.1.5.1.4
dellNetSysAlarmRpmUp 1.3.6.1.4.1.6027.3.26.1.5.1.5
dellNetSysAlarmRpmDown 1.3.6.1.4.1.6027.3.26.1.5.1.6
dellNetSysAlarmPowersupplyDown 1.3.6.1.4.1.6027.3.26.1.5.1.7
dellNetSysAlarmMinorTemperatureHigh 1.3.6.1.4.1.6027.3.26.1.5.1.8
dellNetSysAlarmMajorTemperatureHigh 1.3.6.1.4.1.6027.3.26.1.5.1.9
dellNetSysAlarmFanTrayDown 1.3.6.1.4.1.6027.3.26.1.5.1.10
dellNetSysAlarmPowersupplyClear 1.3.6.1.4.1.6027.3.26.1.5.1.11
dellNetSysAlarmMinorTemperatureClear 1.3.6.1.4.1.6027.3.26.1.5.1.12
dellNetSysAlarmMajorTemperatureClear 1.3.6.1.4.1.6027.3.26.1.5.1.13
dellNetSysAlarmFanTrayClear 1.3.6.1.4.1.6027.3.26.1.5.1.14
--More--

```

## show snmp user

Display the information configured on each SNMP user name.

**Syntax** `show snmp user`

**Command Modes**

- EXEC
- EXEC Privilege

**Supported Modes** Programmable-Mux (PMUX)

**Command History** This guide is platform-specific. For command information about other platforms, refer to the relevant *Dell Networking OS Command Line Reference Guide*.

The following is a list of the Dell Networking OS version history for this command.

Version	Description
9.9(0.0)	Introduced on the M I/O Aggregator.

### Example

```

Dell#show snmp user
User name: test
Engine ID: 0000178B0200000102030407
storage-type: nonvolatile          active
Authentication Protocol: None
Privacy Protocol: None

User name: vlv2cwriteu
Engine ID: 0000178B0200000102030407
storage-type: nonvolatile          active
Authentication Protocol: None
Privacy Protocol: None

Dell#

```

# snmp context

Enables you to map a BGP VRF instance within an SNMP context through community mapping in SNMPv2c and SNMPv3.

<b>Syntax</b>	<code>[no] snmp context [context name]</code>
<b>Parameters</b>	<b>context name</b> Enter a unique name for the context.
<b>Defaults</b>	None
<b>Command Modes</b>	CONFIGURATION
<b>Command History</b>	This guide is platform-specific. For command information about other platforms, see the relevant <i>Dell EMC Networking OS Command Line Reference Guide</i> .

Version	Description
9.14.1.0	Introduced on S4810 and S4820T.
9.13(0.0)	Introduced on all DNOS platforms.

**Usage Information** Use this command to map SNMP context to a VRF instance within a community in SNMPv2c and SNMPv3. The no version of this command turns off this feature.

# snmp-server community

Configure a new community string access for SNMP v3.

**Syntax** `snmp-server community community-name {ro | rw} [ipv6 ipv6-access-list-name [ipv6 ipv6-access-list-name | access-list-name | security-name name] | security-name name [ipv6 ipv6-access-list-name | access-list-name | security-name name] | access-list-name [ipv6 ipv6-access-list-name | access-list-name | security-name name]]]`

To remove access to a community, use the `no snmp-server community community-string {ro | rw} [security-name name [access-list-name | ipv6 access-list-name | access-list-name ipv6 access-list-name]]` command.

<b>Parameters</b>	<b>community-name</b> Enter a text string (up to 20 characters long) to act as a password for SNMP.
	<b>ro</b> Enter the keyword <code>ro</code> to specify read-only permission.
	<b>rw</b> Enter the keyword <code>rw</code> to specify read-write permission.
	<b>ipv6 access-list-name</b> (Optional) Enter the keyword <code>ipv6</code> then an IPv6 ACL name (a string up to 16 characters long).
	<b>security-name name</b> (Optional) Enter the keywords <code>security-name</code> then the security name as defined by the community MIB.
	<b>access-list-name</b> (Optional) Enter a standard IPv4 access list name (a string up to 16 characters long).

<b>Defaults</b>	none
<b>Command Modes</b>	CONFIGURATION
<b>Supported Modes</b>	Programmable-Mux (PMUX)
<b>Command History</b>	This guide is platform-specific. For command information about other platforms, refer to the relevant <i>Dell Networking OS Command Line Reference Guide</i> . The following is a list of the Dell Networking OS version history for this command.

Version	Description
9.9(0.0)	Introduced on the M I/O Aggregator.

### Usage Information

The following example configures a community named *public* that is mapped to the security named *guestuser* with Read Only (*ro*) permissions.

The `security-name` parameter maps the community string to an SNMPv3 user/security name as defined by the community MIB.

If a community string is configured without a `security-name` (for example, `snmp-server community public ro`), the community is mapped to a default security-name/group:

- `v1v2creadu / v1v2creadg` — maps to a community with `ro` (read-only) permissions.
- `v1v2cwriteu/ v1v2cwriteg` — maps to a community with `rw` (read-write) permissions.

The `community-name` parameter indexes this command.

If you do not configure the `snmp-server community` command, you cannot query SNMP data. Only Standard IPv4 ACL and IPv6 ACL is supported in the optional `access-list-name`.

The command options `ipv6`, `security-name`, and `access-list-name` are recursive. In other words, each option can, in turn, accept any of the three options as a sub-option, and each of those sub-options can accept any of the three sub-options as a sub-option, and so forth. The second Example shows the creation of a standard IPv4 ACL called *snmp-ro-acl* and then assigning it to the SNMP community *guest*.

**NOTE:** For IPv6 ACLs, only IPv6 and UDP types are valid for SNMP; TCP and ICMP rules are not valid for SNMP. In IPv6 ACLs, port rules are not valid for SNMP.

### Example

```
Dell#config
Dell(conf)# snmp-server community public ro
Dell(conf)# snmp-server community guest ro security-name guestuser
Dell(conf)#
```

### Example

```
Dell(conf)# ip access-list standard snmp-ro-acl
Dell(config-std-nacl)#seq 5 permit host 10.10.10.224
Dell(config-std-nacl)#seq 10 deny any count
!

Dell(conf)#snmp-server community guest ro snmp-ro-acl
Dell(conf)#
```

### Related Commands

[snmp-server engineID](#)- configures local and remote SNMP engines on the router.

## snmp-server context

Configure a new context to an SNMP server.

### Syntax

```
snmp-server context {line}
```

To remove a user from the SNMP group, use the `snmp-server context {line}` command.

### Parameters

**line** Enter the context string (max 32 characters), on the host that connects to the agent.

### Defaults

As above.

### Command Modes

CONFIGURATION

### Supported Modes

Programmable-Mux (PMUX)

### Command History

This guide is platform-specific. For command information about other platforms, refer to the relevant *Dell Networking OS Command Line Reference Guide*.



The following is a list of the Dell Networking OS version history for this command.

Version	Description
9.9(0.0)	Introduced on the M I/O Aggregator.

#### Example

```
Dell(conf)#snmp-server context ?
LINE          Context String (max 32 chars)
Dell(conf)#snmp-server context test1234 ?
```

#### Related Commands

[show snmp user](#)— displays the information configured on each SNMP user name.

## snmp-server enable traps

Enable SNMP traps.

**Syntax** `snmp-server enable traps [snmp] [stack]`  
To disable traps, use the `no snmp-server enable traps [snmp] [stack]` command.

**Parameters**

<b>stack</b>	Enable stacking role change traps.
<b>snmp</b>	For the <code>snmp</code> notification-type, enter one of the following optional parameters: <ul style="list-style-type: none"><li>linkdown</li><li>linkup</li></ul>

**Defaults** Not enabled.

**Command Modes** CONFIGURATION

**Supported Modes** Programmable-Mux (PMUX)

**Command History** This guide is platform-specific. For command information about other platforms, refer to the relevant *Dell Networking OS Command Line Reference Guide*.

The following is a list of the Dell Networking OS version history for this command.

Version	Description
9.9(0.0)	Introduced on the M I/O Aggregator.

**Usage Information** M I/O Aggregator supports up to 16 SNMP trap receivers.

If this command is not configured, no traps controlled by this command are sent. If you do not specify a notification-type and notification-option, all traps are enabled.

**Related Commands** [snmp-server community](#)- configures a new community string access for SNMP v3.

## snmp-server engineID

Configure the name for both the local and remote SNMP engines on the router.

**Syntax** `snmp-server engineID [local engineID] [remote ip-address]`  
To return to the default, use the `no snmp-server engineID [local engineID] [remote ip-address]` command.

**Parameters**

<b>local engineID</b>	Enter the keyword <code>local</code> followed by the engine ID number that identifies the copy of the SNMP on the local device.
-----------------------	---

Format (as specified in RFC 3411): 12 octets.

- The first four octets are set to the private enterprise number.
- The remaining eight octets are the MAC address of the chassis.

**remote ip-address**

Enter the keyword `remote` followed by the IP address that identifies the copy of the SNMP on the remote device.

**Defaults** As above.

**Command Modes** CONFIGURATION

**Supported Modes** Programmable-Mux (PMUX)

**Command History** This guide is platform-specific. For command information about other platforms, refer to the relevant *Dell Networking OS Command Line Reference Guide*.

The following is a list of the Dell Networking OS version history for this command.

Version	Description
9.9(0.0)	Introduced on the M I/O Aggregator.

**Usage Information**

Changing the value of the SNMP Engine ID has important side effects. A user's password (entered on the command line) is converted to a message digest algorithm (MD5) or secure hash algorithm (SHA) security digest. This digest is based on both the password and the local Engine ID. The command line password is then destroyed, as required by RFC 2274. Because of this deletion, if the local value of the Engine ID changes, the security digests of SNMPv3 users is invalid and the users will have to be reconfigured.

For the remote Engine ID, the host IP and UDP port are the indexes to the command that are matched to either overwrite or remove the configuration.

**Related Commands**

`show snmp engineID` — displays the SNMP engine and all the remote engines that are configured on the router.

## snmp-server group

Configure a new SNMP group or a table that maps SNMP users to SNMP views.

**Syntax**

```
snmp-server group [group_name {1 | 2c | 3 {auth | noauth | priv}}] [read name] [write name] [notify name] [access access-list-name | ipv6 access-list-name | access-list-name ipv6 access-list-name]
```

To remove a specified group, use the `no snmp-server group [group_name {v1 | v2c | v3 {auth | noauth | priv}}] [read name] [write name] [notify name] [access access-list-name | ipv6 access-list-name | access-list-name ipv6 access-list-name]` command.

**Parameters**

**group\_name** Enter a text string (up to 20 characters long) as the name of the group. The following groups are created for mapping to read/write community/security-names (defaults):

- `v1v2creadg` — maps to a community/security-name with `ro` permissions.
- `1v2cwriteg` — maps to a community/security-name `rw` permissions.

**1 | 2c | 3** (OPTIONAL) Enter the security model version number (1, 2c, or 3):

- 1 is the least secure version.
- 3 is the most secure of the security modes.
- 2c allows transmission of informs and counter 64, which allows for integers twice the width of what is normally allowed.

The default is **1**.

<b>auth</b>	(OPTIONAL) Enter the keyword <code>auth</code> to specify authentication of a packet without encryption.
<b>noauth</b>	(OPTIONAL) Enter the keyword <code>noauth</code> to specify no authentication of a packet.
<b>priv</b>	(OPTIONAL) Enter the keyword <code>priv</code> to specify both authentication and then scrambling of the packet.
<b>read name</b>	(OPTIONAL) Enter the keyword <code>read</code> then a name (a string of up to 20 characters long) as the read view name. The default is <b>GlobalView</b> and is assumed to be every object belonging to the internet (1.3.6.1) OID space.
<b>write name</b>	(OPTIONAL) Enter the keyword <code>write</code> then a name (a string of up to 20 characters long) as the write view name.
<b>notify name</b>	(OPTIONAL) Enter the keyword <code>notify</code> then a name (a string of up to 20 characters long) as the notify view name.
<b>access access-list-name</b>	(Optional) Enter the standard IPv4 access list name (a string up to 16 characters long).
<b>ipv6 access-list-name</b>	(Optional) Enter the keyword <code>ipv6</code> then the IPv6 access list name (a string up to 16 characters long).
<b>access-list-name ipv6 access-list-name</b>	(Optional) Enter both an IPv4 and IPv6 access list name.

**Defaults** As above.

**Command Modes** CONFIGURATION

**Supported Modes** Programmable-Mux (PMUX)

**Command History** This guide is platform-specific. For command information about other platforms, refer to the relevant *Dell Networking OS Command Line Reference Guide*.

The following is a list of the Dell Networking OS version history for this command.

Version	Description
9.9(0.0)	Introduced on the M I/O Aggregator.

**Usage Information** The following Example specifies the group named *harig* as a version 3 user requiring both authentication and encryption and read access limited to the read named *rview*.

 **NOTE:** The number of configurable groups is limited to 16 groups.

#### Example

```
Dell#conf
Dell(conf)# snmp-server group harig 3 priv read rview
Dell#
```

**Related Commands** `show snmp group`— displays the group name, security model, view status, and storage type of each group.

## snmp-server host

Configure the recipient of an SNMP trap operation.

**Syntax** `snmp-server host ip-address | ipv6-address [vrf vrf-name] traps | informs [version 1 | 2c | 3] [auth | no auth | priv] [community-string] [udp-port port-number] [notification-type]`

To remove the SNMP host, use the `no snmp-server host ip-address [vrf vrf-name] traps | informs [version 1 | 2c | 3] [auth | noauth | priv] [community-string] [udp-port number] [notification-type]` command.

## Parameters

<b><i>ip-address</i></b>	Enter the keyword <code>host</code> then the IP address of the host (configurable hosts is limited to 16).
<b><i>ipv6-address</i></b>	Enter the keyword <code>host</code> then the IPv6 address of the host in the <code>x:x:x:x::x</code> format. <b>i</b> <b>NOTE:</b> The <code>::</code> notation specifies successive hexadecimal fields of zero.
<b><i>vrf vrf-name</i></b>	Enter the keyword <code>vrf</code> and then the name of the VRF that the SNMP server uses to connect to the host. <b>i</b> <b>NOTE:</b> You can use this attribute to inform the SNMP engine about the vrf instance to be used to reach the corresponding remote host to send Trap or Inform message. If no VRF is specified, then the default VRF is used.
<b><i>traps</i></b>	(OPTIONAL) Enter the keyword <code>traps</code> to send trap notifications to the specified host. The default is <b>traps</b> .
<b><i>informs</i></b>	(OPTIONAL) Enter the keyword <code>informs</code> to send inform notifications to the specified host. The default is <b>traps</b> .
<b><i>version 1   2c   3</i></b>	(OPTIONAL) Enter the keyword <code>version</code> to specify the security model then the security model version number 1, 2c, or 3: <ul style="list-style-type: none"><li>• Version 1 is the least secure version.</li><li>• Version 3 is the most secure of the security modes.</li><li>• Version 2c allows transmission of informs and counter 64, which allows for integers twice the width of what is normally allowed.</li></ul> The default is version <b>1</b> .
<b><i>auth</i></b>	(OPTIONAL) Enter the keyword <code>auth</code> to specify authentication of a packet without encryption.
<b><i>noauth</i></b>	(OPTIONAL) Enter the keyword <code>noauth</code> to specify no authentication of a packet.
<b><i>priv</i></b>	(OPTIONAL) Enter the keyword <code>priv</code> to specify both authentication and then scrambling of the packet.
<b><i>community-string</i></b>	Enter a text string (up to 20 characters long) as the name of the SNMP community. <b>i</b> <b>NOTE:</b> For version 1 and version 2c security models, this string represents the name of the SNMP community. The string can be set using this command; however, Dell Networking OS recommends setting the community string using the <code>snmp-server community</code> command before executing this command. For version 3 security model, this string is the USM user security name.
<b><i>udp-port port-number</i></b>	(OPTIONAL) Enter the keywords <code>udp-port</code> followed by the port number of the remote host to use. The range is from 0 to 65535. The default is <b>162</b> .
<b><i>notification-type</i></b>	(OPTIONAL) Enter one of the following keywords for the type of trap to be sent to the host: <ul style="list-style-type: none"><li>• <code>bgp</code> — Enable BGP state change traps.</li><li>• <code>ecfm</code> — Enable ECFM state change traps.</li><li>• <code>entity</code> — Enable entity change traps.</li><li>• <code>envmon</code> — Enable SNMP environmental monitor traps.</li><li>• <code>eoam</code> — Enable EOAM state change traps</li><li>• <code>ets</code> — Enable ets traps</li><li>• <code>fips</code> — Enable FIP Snooping state change traps</li><li>• <code>lACP</code> — Enable LACP state change traps.</li><li>• <code>isis</code> — Enable ISIS adjacency change traps</li><li>• <code>pfc</code> — Enable pfc traps</li><li>• <code>snmp</code> — Enable SNMP trap</li><li>• <code>stp</code> — Enable 802.1d state change traps</li><li>• <code>vlt</code> — Enable VLT traps</li></ul>

- `vrrp` — Enable VRRP state change traps
- `xstp` — Enable 802.1s, 802.1w, and PVST+ state change traps

The default is all trap types are sent to host.

**Defaults** As above.

**Command Modes** CONFIGURATION

**Supported Modes** Programmable-Mux (PMUX)

**Command History** This guide is platform-specific. For command information about other platforms, refer to the relevant *Dell Networking OS Command Line Reference Guide*.

The following is a list of the Dell Networking OS version history for this command.

Version	Description
9.9(0.0)	Introduced on the M I/O Aggregator.

### Usage Information

In order to configure the router to send SNMP notifications, enter at least one `snmp-server host` command. If you enter the command with no keywords, all trap types are enabled for the host. If you do not enter an `snmp-server host` command, no notifications are sent.

In order to enable multiple hosts, issue a separate `snmp-server host` command for each host. You can specify multiple notification types in the command for each host.

When multiple `snmp-server host` commands are given for the same host and type of notification (trap or inform), each succeeding command overwrites the previous command. Only the last `snmp-server host` command will be in effect. For example, if you enter an `snmp-server host inform` command for a host and then enter another `snmp-server host inform` command for the same host, the second command replaces the first command.

The `snmp-server host` command is used with the `snmp-server enable` command. Use the `snmp-server enable` command to specify which SNMP notifications are sent globally. For a host to receive most notifications, at least one `snmp-server enable` command and the `snmp-server host` command for that host must be enabled.

**NOTE:** For v1 / v2c trap configuration, if the community-string is not defined using the `snmp-server community` command prior to using this command, the default form of the `snmp-server community` command automatically is configured with the community-name the same as specified in the `snmp-server host` command.

### Configuring Informs

To send an inform, use the following steps:

1. Configure a remote engine ID.
2. Configure a remote user.
3. Configure a group for this user with access rights.
4. Enable traps.
5. Configure a host to receive informs.

### Related Commands

[snmp-server enables](#)— enables SNMP traps.

## snmp-server user

Configure a new user to an SNMP group.

**Syntax** `snmp-server user name {group_name [access access-list-name | ipv6 access-list-name | access-list-name ipv6 access-list-name]}`

To remove a user from the SNMP group, use the `no snmp-server user name {group_name [access access-list-name | ipv6 access-list-name | access-list-name ipv6 access-list-name]}` command.

<b>Parameters</b>	<p><b>name</b> Enter the name of the user (not to exceed 20 characters), on the host that connects to the agent.</p> <p><b>group_name</b> Enter a text string (up to 20 characters long) as the name of the group. The following groups are created for mapping to read/write community/security-names (defaults):</p> <ul style="list-style-type: none"> <li>• v1v2creadu — maps to a community with ro permissions.</li> <li>• 1v2cwriteu — maps to a community rw permissions.</li> </ul> <p><b>access access-list-name</b> (Optional) Enter the standard IPv4 access list name (a string up to 16 characters long).</p> <p><b>ipv6 access-list-name</b> (Optional) Enter the keyword <code>ipv6</code> then the IPv6 access list name (a string up to 16 characters long).</p> <p><b>access-list-name ipv6 access-list-name</b> (Optional) Enter both an IPv4 and IPv6 access list name.</p>
-------------------	--

**Defaults** As above.

**Command Modes** CONFIGURATION

**Supported Modes** Programmable-Mux (PMUX)

**Command History** This guide is platform-specific. For command information about other platforms, refer to the relevant *Dell Networking OS Command Line Reference Guide*.

The following is a list of the Dell Networking OS version history for this command.

<b>Version</b>	<b>Description</b>
<b>9.9(0.0)</b>	Introduced on the M I/O Aggregator.

**Usage Information**  **NOTE:** For IPv6 ACLs, only IPv6 and UDP types are valid for SNMP. TCP and ICMP rules are not valid for SNMP. In IPv6 ACLs port rules are not valid for SNMP.

No default values exist for authentication or privacy algorithms and no default password exists. If you forget a password, you cannot recover it; the user must be reconfigured. You can specify either a plain-text password or an encrypted cypher-text password. In either case, the password is stored in the configuration in an encrypted form and displayed as encrypted in the `show running-config` command.

If you have an encrypted password, you can specify the encrypted string instead of the plain-text password. The following command is an Example of how to specify the command with an encrypted string.

 **NOTE:** The number of configurable users is limited to 16.

**Example**

```
Dell# snmp-server user privuser v3group v3 encrypted auth md5
9fc53d9d908118b2804fe80e3ba8763d priv des56
d0452401a8c3ce42804fe80e3ba8763d
```

**Usage Information** The following command is an example of how to enter a plain-text password as the string `authpasswd` for user `authuser` of group `v3group`.

**Example**

```
Dell#conf
Dell(conf)# snmp-server user authuser v3group v3 auth md5 authpasswd
```

**Usage Information** The following command configures a remote user named `n3user` with a `v3` security model and a security level of `authNOPriv`.

## Example

```
Dell#conf
Dell(conf)# snmp-server user n3user ngroup remote 172.31.1.3 udp-port
5009 3
auth md5 authpasswd
```

## Related Commands

[show snmp user](#)— displays the information configured on each SNMP user name.

# snmp-server view

Configure an SNMPv3 view.

## Syntax

```
snmp-server view view-name oid-tree {included | excluded}
```

To remove an SNMPv3 view, use the `no snmp-server view view-name oid-tree {included | excluded}` command.

## Parameters

<b>view-name</b>	Enter the name of the view (not to exceed 20 characters).
<b>oid-tree</b>	Enter the OID sub tree for the view (not to exceed 20 characters).
<b>included</b>	(OPTIONAL) Enter the keyword <code>included</code> to include the MIB family in the view.
<b>excluded</b>	(OPTIONAL) Enter the keyword <code>excluded</code> to exclude the MIB family in the view.

## Defaults

none

## Command Modes

CONFIGURATION

## Supported Modes

Programmable-Mux (PMUX)

## Command History

This guide is platform-specific. For command information about other platforms, refer to the relevant *Dell Networking OS Command Line Reference Guide*.

The following is a list of the Dell Networking OS version history for this command.

Version	Description
9.9(0.0)	Introduced on the M I/O Aggregator.

## Usage Information

The `oid-tree` variable is a full sub-tree starting from 1.3.6 and cannot specify the name of a sub-tree or a MIB. The following Example configures a view named `rview` that allows access to all objects under 1.3.6.1.

## Example

```
Dell# conf
Dell#(conf) snmp-server view rview 1.3.6.1 included
```

## Related Commands

[show running-config snmp](#) — displays the SNMP running configuration.

## Stacking Commands

Stacking is supported on an Aggregator only on the 40GbE ports on the base module. Stacking is limited to two Aggregators in the same chassis in a single stack. Up to three stacks are supported in an M1000e chassis.

Stacking provides a single point of management and NIC teaming for high availability and higher throughput. To configure an Aggregator stack, you must use the CLI.

The stacking commands are always available and operational, whether or not an Aggregator has a stacking module inserted. You can use the commands to pre-configure an Aggregator, so that the configuration settings are invoked when the Aggregator is attached to other Aggregator blades.

For more information about using the Aggregator stacking feature, refer to the *Stacking Aggregators* chapter in the Dell Networking OS Configuration Guide for the M I/O Aggregator.

You can use the following commands to manage a stack of Aggregator I/O modules:

- `power-cycle stack-unit`
- `reset stack-unit`
- `show system stack-ports`
- `show system stack-unit iom-mode`
- `show system stack-unit stack-group`
- `stack-unit iom-mode`

**i** **NOTE:** The terms `stack-unit-id`, `unit-id`, `stack-unit-number`, `stack-number`, and `unit-number` mentioned in this chapter refers to the `stack-unit-number`.

### Topics:

- `power-cycle stack-unit`
- `reset stack-unit`
- `show system stack-ports`
- `show system stack-unit fanout`
- `show system stack-unit iom-mode`
- `show system stack-unit iom-uplink-speed`
- `show system stack-unit stack-group`
- `stack-unit iom-mode`
- `stack-unit iom-mode uplink-speed`
- `stack-unit priority`
- `stack-unit renumber`

## power-cycle stack-unit

To hard reset any stack unit including master unit.

**Syntax** `power-cycle stack-unit unit-number`

**Parameter** **Unit number** The unit number ranges from 0 to 5.

**Defaults** None

**Command Modes** EXEC Privilege

**Supported Modes** All Modes

Command History	Version	Description
	9.6.(0.0)	Supported on the FN I/O Aggregator.



Version	Description
8.3.17.0	Supported on the M I/O Aggregator.

**Usage Information**

This command is supported on the M I/O, FN410S, and FN410T Aggregators.

This command is used to reset the stack-unit. The master unit can also be power cycled using this command.

## reset stack-unit

Reset any designated stack member except the management unit (master unit).

**Syntax**                 reset stack-unit 0-5 hard

**Parameters**

**0-5**                     Enter the stack member unit identifier of the stack member to reset.

**hard**                   Reset the stack unit if the unit is in a problem state.

**Defaults**             none

**Command Modes**     EXEC Privilege

**Supported Modes**   All Modes

**Command History**

Version	Description
9.6.(0.0)	Supported on the FN I/O Aggregator.
8.3.17.0	Supported on the M I/O Aggregator.

**Usage Information**

This command is supported on the M I/O, FN410S, and FN410T Aggregators

Resetting the management unit is not allowed and an error message displays if you try to do so. Resetting is a soft reboot, including flushing the forwarding tables.

You can run this command directly on the stack standby unit (Standby Master) to reset the standby. You cannot reset any other unit from the standby unit

**Example**

```
Dell#show system brief
Stack MAC : 00:1e:c9:f1:00:9b
-- Stack Info --
Unit      UnitType      Status      ReqTyp      CurTyp      Version      Ports
-----
0         Management    online      I/O-Aggregator I/O-Aggregator 8-3-17-46  56
1         Standby       online      I/O-Aggregator I/O-Aggregator 8-3-17-46  56
2         Member        not present
3         Member        not present
4         Member        not present
5         Member        not present
Dell#
Dell#reset stack-unit 0 >>>Resetting master not allowed
% Error: Reset of master unit is not allowed.
Dell#
Dell#reset stack-unit 1
Dell#01:02:00: %STKUNIT0-M:CP %CHMGR-5-STACKUNIT RESET: Stack unit 1 being reset
01:02:00: %STKUNIT0-M:CP %IFMGR-1-DEL_PORT: Removed port: Te 1/1-32,41-56
01:02:00: %STKUNIT0-M:CP %CHMGR-2-STACKUNIT_DOWN: Stack unit 1 down - reset
01:02:00: %STKUNIT1-S:CP %IFMGR-1-DEL_PORT: Removed port: Te 1/1-32,41-56
01:02:05: %I/O-Aggregator:0 %IFAGT-5-STACK_PORT_LINK_DOWN: Changed stack port
state to down: 0/10
01:02:11: %STKUNIT0-M:CP %POLLMGR-2-ALT_STACK_UNIT_STATE: Alternate Stack-unit is
not present
Dell#01:02:12: %STKUNIT0-M:CP %CHMGR-2-STACKUNIT_DOWN: Stack unit 1 down - card
removed
```

**Related Commands**

[reload](#)— reboots the system.

# show system stack-ports

Display information about the stacking ports on all switches in the M I/O Aggregator switch stack..

**Syntax** `show system stack-ports [status | topology]`

**Parameters**

- status** (OPTIONAL) Enter the keyword `status` to display the command output without the Connection field.
- topology** (OPTIONAL) Enter the keyword `topology` to limit the table to just the Interface and Connection fields.

**Defaults** none

- Command Modes**
- EXEC
  - EXEC Privilege

**Supported Modes** All Modes

**Command History**

Version	Description
8.3.17.0	Supported on the M I/O Aggregator.

**Usage Information** The following describes the `show interfaces` command shown in the following example.

Field	Description
<b>Topology</b>	Lists the topology of stack ports connected: Ring, Daisy chain, or Standalone.
<b>Interface</b>	The unit/port ID of the connected stack port on this unit.
<b>Link Speed</b>	Link Speed of the stack port (10 or 40) in Gb/s.
<b>Admin Status</b>	The only currently listed status is Up.
<b>Connection</b>	The stack port ID to which this unit's stack port is connected.

## Example

```
Dell# show system stack-ports
Topology: Ring

Interface Connection Link Speed      Admin Link Trunk
              (Gb/s)      Status Status Group
0/33          40          up    down
0/37          40          up     up
1/33          40          up    down
1/37          40          up     up
Dell#
```

## Example (Status)

```
Dell# show system stack-ports status
Topology: Daisy chain
Interface Link Speed      Admin Link Trunk
              (Gb/s)      Status Status Group
0/33          40          up    down
0/37          40          up     up
1/33          40          up    down
1/37          40          up     up
```

## Example (Topology)

```
Dell# show system stack-ports topology
Topology: Daisy chain

Interface Connection Trunk
              Group

0/33
0/37          1/37
1/33
```

```
1/37      0/37
Dell      #
```

### Related Commands

[power-cycle stack-unit](#)—resets the designated stack member.

[show diag](#)— displays the data plane or management plane input and output statistics of the designated component of the designated stack member.

[show system](#)—displays the current status of all stack members or a specific member.

## show system stack-unit fanout

Displays the current 40GbE ports configured in fanout mode.

**Syntax** `show system stack-unit <unit-number> fanout[configured]`

**Parameters** *unit-number* <0-5> Enter the number of the member stack unit. The range is from 0 to 5.

**Defaults** none

**Command Modes** • EXEC Privilege

**Supported Modes** All Modes

### Command History

Version	Description
8.3.17.0	Supported on the M I/O Aggregator.

### Example

```
Dell#show system stack-unit 0 fanout ?
configured Configured fan out ports
Dell#show system stack-unit 0 fanout configured ?
| Pipe through a command
<cr>
Dell#show system stack-unit 0 fanout configured
Configured fan out ports in stack-unit 0
Configured Next Boot
33          33
37          37
41          41
45          45
Dell#
```

## show system stack-unit iom-mode

Displays the current iom-mode (stack/standalone) and the mode configured after next reboot.

**Syntax** `show system stack-unit unit-number iom-mode`

**Parameters** *unit number* <0-5> Enter the number of the member stack unit. The range is from 0 to 5.

**Command Modes** EXEC Privilege

**Supported Modes** All Modes

### Command History

Version	Description
9.6.(0.0)	Supported on the FN I/O Aggregator.
8.3.17.0	Supported on the M I/O Aggregator.

## Usage information

This command is supported on the M I/O, FN410S, and FN410T Aggregators

### Example

```
Dell#show system stack-unit all iom-mode ?
|
| Pipe through a command
|
|<cr>
Dell#show system stack-unit all iom-mode
Unit          Boot-Mode          Next-Boot
-----
0             stack             stack
1             stack             stack
2             stack             stack
3             stack             stack
4             Not Present
5             Not Present
Dell#
```

## show system stack-unit iom-uplink-speed

Display the uplink speed of the LAG bundles configured on the Flex IO modules installed on the Aggregator.

**Syntax** `show system stack-unit unit-number iom-uplink-speed`

**Parameters** *unit number* <0-5> Enter the number of the member stack unit. The range is from 0 to 5.

**Command Modes** EXEC Privilege

**Supported Modes** All Modes

Command History	Version	Description
	9.3(0.0)	Introduced on the M I/O Aggregator

**Usage Information** The value under the Boot-speed field in the output of the show command indicates the uplink speed that is currently effective on the LAG bundles, whereas the value under the Next-Boot field indicates the uplink speed that is applicable for the LAG bundle after the next reboot of the switch.

### Example

```
Dell# show system stack-unit 0 iom-uplink-speed
Unit      Boot-speed      Next-Boot
-----
0         10G             40G
```

## show system stack-unit stack-group

Displays the stack-groups present/configured for a M I/O Aggregator stack unit.

**Syntax** `show system stack-unit unit-number stack-group [configured]`

**Parameters** *unit number* <0-5> Enter the number of the member stack unit. The range is from 0 to 5.

**Defaults** none

**Command Modes** EXEC Privilege

**Supported Modes** All Modes

Command History	Version	Description
	8.3.17.0	Supported on the M I/O Aggregator.

## Example

```
Dell#show system stack-unit 0 stack-group ?
configured          Configured stack groups
|                  Pipe through a command
<cr>
Dell#show system stack-unit 0 stack-group configured
Configured stack groups in stack-unit 0
Dell#show system stack-unit 0 stack-group
Stack group Ports
-----
0                0/33
1                0/37
2                0/41
3                0/45
Dell#
```

## Related Commands

[reload](#)— reboots the system.

[show system](#)— displays the current status of all stack members or a specific member.

# stack-unit iom-mode

Toggle the operating mode between programmable multiplex, standalone, stack, and VLT modes.

## Syntax

```
stack-unit <unit-number> iom-mode [programmable-mux | stack | standalone |
vlt | full-switch
```

## Parameters

<b>unit number</b> <b>&lt;0-5&gt;</b>	Enter the number of the member stack unit. The range is from 0 to 5.
<b>programmable-mux</b>	Enable programmable multiplex mode.
<b>stack</b>	Enable stack mode.
<b>standalone</b>	Enable stand-alone mode.
<b>vlt</b>	Enable virtual link trunking mode.

## Defaults

standalone

## Command Modes

- CONFIGURATION

## Supported Modes

All Modes

## Command History

Version	Description
<b>9.6.(0.0)</b>	Supported on the FN I/O Aggregator.
<b>8.3.17.0</b>	Supported on the M I/O Aggregator.

## Usage Information

This command is supported on the M I/O, FN410S, and FN410T Aggregators.

## Example

```
Dell(conf)#stack-unit 0 iom-mode stack
% You are about to stack your IOA module, please reload the IOA
and then plug in the stacking cable for the changes to take effect.
Dell(conf)#
Dell#
```

## Related Commands

[reload](#)— Reboots the operating system.

[show system](#)— displays the current status of all stack members or a specific member.

# stack-unit iom-mode uplink-speed

Specify the uplink speed of the member interfaces in a LAG bundle for the Aggregator that operates in standalone, stacking, or VLT mode to be 40 GbE. By default, the uplink speed of the LAG bundle is set as 10 GbE.

**Syntax** `stack-unit unit-number iom-mode {stack | standalone | vlt} uplink-speed 40G`

To restore the default uplink speed of the LAG bundle, which is 10 GbE, use the `stack-unit unit-number iom-mode {stack | standalone | vlt}` command.

<b>Parameters</b>	<b><i>unit number</i></b> <b>&lt;0-5&gt;</b>	Enter the number of the member stack unit. The range is from 0 to 5.
	<b>iom-mode</b>	Denotes the operating mode of the I/O Aggregator.
	<b>stack</b>	Specify that the uplink speed of the member interfaces in a LAG bundle applies for the Aggregator in stacking mode
	<b>standalone</b>	Specify that the uplink speed of the member interfaces in a LAG bundle applies for the Aggregator in standalone mode
	<b>vlt</b>	Specify that the uplink speed of the member interfaces in a LAG bundle applies for the Aggregator in VLT mode
	<b>uplink-speed 40G</b>	Set the uplink speed of the member or child interfaces of the LAG bundle to function at 40 Gigabit Ethernet per second

**Command Modes** CONFIGURATION

**Supported Modes** All Modes

<b>Command History</b>	<b>Version</b>	<b>Description</b>
	9.3(0.0)	Supported on the M I/O Aggregator

**Usage Information** This functionality to set the uplink speed is available from the CMC interface when the I/O Aggregator functions as a simple MUX or a VLT node with all of the uplink interfaces configured to be member links in the same LAG bundle. You cannot configure the uplink speed to be set as 40 GbE by default if the Aggregator functions in programmable MUX mode with multiple uplink LAG interfaces or in stacking mode because CMC is not involved with configuration of parameters when the Aggregator operates in either of these modes with uplink interfaces being part of different LAG bundles.

When you configure the native mode to be 40 GbE, the CMC sends a notification to the IOA to set the default internal working of all of the ports to be 40 GbE after the reload of the switch is performed. After you configure the native mode that denotes the uplink speed of the module ports to be 40 GbE, you must enter the `reboot` command (not pressing the Reset button, which causes the factory default settings to be applied when the device comes up online) from the CMC to cause the configuration of the uplink speed to be effective.

# stack-unit priority

Configure the ability of a switch to become the management unit of a stack.

**Syntax** `stack-unit stack-number priority 1-14`

<b>Parameters</b>	<b><i>stack-number</i></b> <b>1-14</b>	Enter the stack member unit identifier.  This preference parameter allows you to specify the management priority of one backup switch over another, with 0 the lowest priority and 14 the highest. The switch with the highest priority value is chosen to become the management unit if the active management unit fails or on the next reload.
-------------------	---	--

**Defaults** 0

**Command Modes** CONFIGURATION

**Supported Modes** All Modes

Command History	Version	Description
	<b>9.6.(0.0)</b>	Supported on the FN I/O Aggregator.
	<b>9.3(0.0)</b>	Supported on the M I/O Aggregator.

**Usage Information** This command is supported on the M I/O, FN410S, and FN410T Aggregators.

**Related Commands**

- [reload](#) – reboots Dell Networking Operating System (OS).
- [show system](#) – displays the status of all stack members or a specific member.

## stack-unit renumber

Change the stack member ID of any stack member or a stand-alone unit.

**Syntax** `stack-unit 0-5 renumber 0-5`

**Parameters** **0-5** The first instance of this value is the stack member unit identifier, from 0 to 5, of the switch that you want add to the stack. The range is from 0 to 5. The second instance of this value is the desired new unit identifier number.

**Defaults** none

**Command Modes** EXEC Privilege

**Supported Modes** All Modes

Command History	Version	Description
	<b>9.6.(0.0)</b>	Supported on the FN I/O Aggregator.
	<b>9.3(0.0)</b>	Supported on the M I/O Aggregator.

**Usage Information** This command is supported on the FN410S and the FN410T Aggregators.

You can renumber any switch, including the management unit or a stand-alone unit.

You cannot renumber a unit to a number of an active member in the stack.

When executing this command on the master, the stack reloads. When the members are renumbered, only that specific unit is reset and comes up with the new unit number.

### Example

```
Dell#stack-unit 5 renumber 4

Renumbering will reset the unit.
Warning: Interface configuration for current unit will be lost!
Proceed to renumber [confirm yes/no]:
```

**Related Commands**

- [reload](#) – reboots Dell Networking Operating System (OS).
- [reset stack-unit](#) – resets the designated stack member.
- [show system](#) – displays the current status of all stack members or a specific member.

# Storm Control

The Dell Networking operating software storm control feature allows you to limit or suppress traffic during a traffic storm.

## Important Points to Remember

- Interface commands can only be applied on physical interfaces (virtual local area networks [VLANs] and link aggregation group [LAG] interfaces are not supported).
  - An INTERFACE-level command only supports storm control configuration on ingress.
  - An INTERFACE-level command overrides any CONFIGURATION-level ingress command for that physical interface, if both are configured.
  - You can apply the CONFIGURATION-level storm control commands at ingress or egress and are supported on all physical interfaces.
  - When storm control is applied on an interface, the percentage of storm control applied is calculated based on the advertised rate of the line card. It is not based on the speed setting for the line card.
  - Do not apply per-VLAN quality of service (QoS) on an interface that has storm control enabled (either on an interface or globally).
  - When you enable broadcast storm control on an interface or globally on ingress, and DSCP marking for a DSCP value 1 is configured for the data traffic, the traffic goes to queue 1 instead of queue 0.
  - Similarly, if you enable unicast storm control on an interface or globally on ingress, and DSCP marking for a DSCP value 2 is configured for the data traffic, the traffic goes to queue 2 instead of queue 0.
- i NOTE:** Bi-directional traffic (unknown unicast and broadcast) along with egress storm control causes the configured traffic rates split between the involved ports. The percentage of traffic that each port receives after the split is not predictable. These ports can be in the same/different port pipes or the same/different line cards.
- i NOTE:** The policy discard drop counters are common across storm-control drops, ACL drops and QoS drops. Therefore, if your configuration includes ACL and QoS, those drops are also computed and displayed in the policy discard drops counter field along with storm-control drops. The packets dropped by the storm control feature can be monitored by viewing the value of the Policy Discard Drops field of the output of the `show hardware stack-unit 0 drops` command.

### Topics:

- [io-aggregator broadcast storm-control](#)
- [show io-aggregator broadcast storm-control status](#)
- [storm-control PFC/LLFC](#)
- [storm-control multicast \(Interface\)](#)
- [storm-control broadcast \(Interface\)](#)
- [show storm-control unknown-unicast](#)
- [storm-control unknown-unicast \(Interface\)](#)

## io-aggregator broadcast storm-control

Rate-limit the traffic storm to 1 Gbps.

<b>Syntax</b>	<code>io-aggregator broadcast storm-control</code> To disable storm control, use the <code>no io-aggregator broadcast storm-control</code> command.
<b>Defaults</b>	Enabled
<b>Command Modes</b>	• CONFIGURATION
<b>Supported Modes</b>	Standalone-Mux (SMUX)



Command History	Version	Description
	9.4(0.0)	Supported on the FN I/O Aggregator.
	9.2(0.0)	Introduced on the M I/O Aggregator.

**Usage Information** This command is not available in PMUX mode.

## show io-aggregator broadcast storm-control status

Shows if storm control is enabled or disabled. If enabled, displays information on the rate limit value.

**Syntax** `show io-aggregator broadcast storm-control status`

**Command Modes** • EXEC Privilege

**Supported Modes** Standalone-Mux (SMUX)

Command History	Version	Description
	9.4(0.0)	Supported on the FN I/O Aggregator.
	8.3.17.0	Supported on the M I/O Aggregator.

### Example

```
Dell#show io-aggregator broadcast storm-control status
Storm-Control Enabled
Broadcast Traffic limited to 1000 Mbps
Dell#
```

## storm-control PFC/LLFC

Shut down the port if it receives the PFC/LLFC frames more than the configured rate.

**Syntax** `storm-control pfc-llfc [pps]in shutdown`

**Parameters**

- pfc-llfc* in** Enter the keyword *pfc-llfc* to get the flow control traffic. The range is from 0 to 33554368 packets per second.
- shutdown** Enter the keyword *shutdown* to shut down the port when the rate exceeds.

**Defaults** none

**Command Modes** INTERFACE (*conf-if-interface-slot/port*)

**Command History** This guide is platform-specific. For command information about other platforms, see the relevant *Dell Networking OS Command Line Reference Guide*.

The following is a list of the Dell Networking OS version history for this command.

Version	Description
9.9(0.0)	Supported on the FN IOM, FN I/O Aggregator, and M I/O Aggregator

### Usage Information

**NOTE:** PFC/LLFC storm control enabled interfaces disable the interfaces if it receives continuous PFC/LLFC packets. It can be a result of a faulty NIC/Switch that sends spurious PFC/LLFC packets.

## storm-control multicast (Interface)

Configure the percentage of multicast traffic allowed on the interface.

**Syntax** `storm-control multicast packets_per_second in`  
To disable multicast storm control on the interface, use the `no storm-control multicast packets_per_second in` command.

**Parameters** **packets\_per\_second** Enter the packets per second of broadcast traffic allowed into the network. The range is from 0 to 33554368.

**Command Modes** INTERFACE (conf-if-interface-slot/port)

**Supported Modes** Programmable-Mux (PMUX)

Command History	Version	Description
	9.4(0.0)	Supported on the FN I/O Aggregator.
	9.2(0.0)	Supported on the M I/O Aggregator.

## storm-control broadcast (Interface)

Configure the percentage of broadcast traffic allowed on an interface.

**Syntax** `storm-control broadcast [packets_per_second in]`  
To disable broadcast storm control on the interface, use the `no storm-control broadcast [packets_per_second in]` command.

**Parameters** **packets\_per\_second** Enter the packets per second of broadcast traffic allowed into the network. The range is from 0 to 33554368.

**Command Modes** INTERFACE (conf-if-interface-slot/port)

**Supported Modes** Programmable-Mux (PMUX)

Command History	Version	Description
	9.4(0.0)	Supported on the FN I/O Aggregator.
	9.2(0.0)	Introduced on the M I/O Aggregator.

## show storm-control unknown-unicast

Display the storm control unknown-unicast configuration.

**Syntax** `show storm-control unknown-unicast [interface]`

**Parameters** **interface** (OPTIONAL) Enter one of the following interfaces to display the interface specific storm control configuration:

- For a 1-Gigabit Ethernet interface, enter the keyword `GigabitEthernet` then the slot/port information.
- For a 10-Gigabit Ethernet interface, enter the keyword `TenGigabitEthernet` then the slot/port information.
- For a 40-Gigabit Ethernet interface, enter the keyword `fortyGigE` then the slot/ port information.

**Defaults** none

- Command Modes**
- EXEC
  - EXEC Privilege

**Supported Modes** Programmable-Mux (PMUX)

**Command History** This guide is platform-specific. For command information about other platforms, refer to the relevant *Dell Networking OS Command Line Reference Guide*.

The following is a list of the Dell Networking OS version history for this command.

Version	Description
9.2(0.0)	Introduced on the M I/O Aggregator.

## storm-control unknown-unicast (Interface)

Configure percentage of unknown-unicast traffic allowed on the interface.

**Syntax** `storm-control unknown-unicast [packets_per_second in]`

To disable unknown-unicast storm control on the interface, use the `no storm-control unknown-unicast [packets_per_second in]` command.

**Parameters**

***packets\_per\_second*** Enter the packets per second of broadcast traffic allowed into the network. The range is from 0 to 33554431.

**Command Modes** INTERFACE (*conf-if-interface-slot/port*)

**Supported Modes** Programmable-Mux (PMUX)

**Command History**

Version	Description
9.4(0.0)	Supported on the FN I/O Aggregator.
9.2(0.0)	Introduced on the M I/O Aggregator.

# SupportAssist

SupportAssist sends troubleshooting data securely to Dell. SupportAssist in this Dell EMC Networking OS release does not support automated email notification at the time of hardware fault alert, automatic case creation, automatic part dispatch, or reports. SupportAssist requires Dell EMC Networking OS 9.9(0.0) and SmartScripts 9.7 or later to be installed on the Dell EMC Networking device. For more information on SmartScripts, see *Dell EMC Networking Open Automation guide*.

**NOTE:** SupportAssist is enabled by default on the system. To disable SupportAssist, enter the `eula-consent support-assist reject` command in Global Configuration mode and save the configuration.

## Topics:

- [eula-consent](#)
- [support-assist](#)
- [support-assist activate](#)
- [support-assist activity](#)
- [SupportAssist Commands](#)
- [SupportAssist Activity Commands](#)
- [SupportAssist Company Commands](#)
- [SupportAssist Person Commands](#)
- [SupportAssist Server Commands](#)
- [show eula-consent](#)
- [show running-config](#)
- [show support-assist status](#)

## eula-consent

Accept or reject the end user license agreement (EULA).

**Syntax** `eula-consent {support-assist} {accept | reject}`

**Parameters**

<b>support-assist</b>	Enter the keywords <code>support-assist</code> to either accept or reject the EULA for the specified service.
<b>accept</b>	Enter the keyword <code>accept</code> to accept the EULA for the specified service.
<b>reject</b>	Enter the keyword <code>reject</code> to reject the EULA for the specified service.

**Defaults** None

**Command Modes** CONFIGURATION

**Command History** This guide is platform-specific. For command information about other platforms, see the relevant *Dell EMC Networking OS Command Line Reference Guide*.

Version	Description
<b>9.11(0.0)</b>	Introduced on the M I/O Aggregator and FN IOM.
<b>9.10(0.1)</b>	Introduced on the S6010-ON and S4048T-ON.
<b>9.10(0.0)</b>	Introduced on the S3148.
<b>9.10(0.0)</b>	Introduced on the C9010, Z9100-ON, S6100-ON, and S3100 series.
<b>9.9(0.0)</b>	Introduced on the S4810, S4820T, S3048-ON, S4048-ON, S5000, S6000, S6000-ON, Z9500, MXL.

## Usage Information

- When you run the command, the system displays a message with the information directing to the URL for further information.
- Even before you accept or reject the EULA, the configuration data is sent to the default centrally deployed SupportAssist Server. If you reject the EULA, the configuration data is not transmitted to the SupportAssist server.
- If there is an existing SupportAssist configuration, the configuration is not removed and the feature is disabled.

## Example

Accept the EULA:

```
DelleMC(conf)# eula-consent support-assist accept
I accept the terms of the license agreement. You can reject
the license agreement by configuring this command
'eula-consent support-assist reject'.
```

By installing SupportAssist, you allow Dell to save your contact information (e.g. name, phone number and/or email address) which would be used to provide technical support for your Dell products and services. Dell may use the information for providing recommendations to improve your IT infrastructure.

Dell SupportAssist also collects and stores machine diagnostic information, which may include but is not limited to configuration information, user supplied contact information, names of data volumes, IP addresses, access control lists, diagnostics & performance information, network configuration information, host/server configuration & performance information and related data ("Collected Data") and transmits this information to Dell. By downloading SupportAssist and agreeing to be bound by these terms and the Dell end user license agreement, available at: [www.dell.com/aeula](http://www.dell.com/aeula), you agree to allow Dell to provide remote monitoring services of your IT environment and you give Dell the right to collect the Collected Data in accordance with Dells Privacy Policy, available at: [www.dell.com/privacypolicycountryspecific](http://www.dell.com/privacypolicycountryspecific), in order to enable the performance of all of the various functions of SupportAssist during your entitlement to receive related repair services from Dell,. You further agree to allow Dell to transmit and store the Collected Data from SupportAssist in accordance with these terms. You agree that the provision of SupportAssist may involve international transfers of data from you to Dell and/or to Dells affiliates, subcontractors or business partners. When making such transfers, Dell shall ensure appropriate protection is in place to safeguard the Collected Data being transferred in connection with SupportAssist. If you are downloading SupportAssist on behalf of a company or other legal entity, you are further certifying to Dell that you have appropriate authority to provide this consent on behalf of that entity. If you do not consent to the collection, transmission and/or use of the Collected Data, you may not download, install or otherwise use SupportAssist.

Reject the EULA:

```
DelleMC(conf)#eula-consent support-assist reject
Aug 24 22:35:38: %STKUNIT1-M:CP %SUPPORT_ASSIST-6-SUPASSIST_EVT: Event
monitor service stopped
I do not accept the terms of the license agreement. The SupportAssist
feature has
been deactivated and can no longer be used.
To enable SupportAssist configurations, accept the terms of the license
agreement
by configuring this command 'eula-consent support-assist accept'.
DelleMC(conf)#
DelleMC(conf)#
Aug 24 22:35:49: %STKUNIT1-M:CP %SUPPORT_ASSIST-6-
SUPASSIST_PKG_UNINSTALLED: SupportAssist package uninstalled
DelleMC(conf)#
```

## Related Commands

- [support-assist](#) — moves to the SupportAssist Configuration mode.

# support-assist

Move to the SupportAssist configuration mode.

**Syntax** `support-assist`  
To remove all the configuration of the SupportAssist service, use the `no support-assist` command.

**Command Modes** CONFIGURATION

**Command History** This guide is platform-specific. For command information about other platforms, see the relevant *Dell EMC Networking OS Command Line Reference Guide*.

Version	Description
9.11(0.0)	Introduced on the M I/O Aggregator and FN IOM.
9.10(0.1)	Introduced on the S6010-ON and S4048T-ON.
9.10(0.0)	Introduced on the S3148.
9.10(0.0)	Introduced on the C9010, Z9100-ON, S6100-ON, and S3100 series.
9.9(0.0)	Introduced on the S4810, S4820T, S3048-ON, S4048-ON, S5000, S6000, S6000-ON, Z9500, MXL.

**Usage Information** If you reject the EULA, the data is not transmitted to the SupportAssist server.

**Related Commands** • [eula-consent](#) — accept or reject the EULA.

# support-assist activate

Launch the configuration wizard that enables SupportAssist service and guides through a series of commands to configure SupportAssist.

**Syntax** `support-assist activate`

**Command Modes** CONFIGURATION

**Command History** This guide is platform-specific. For command information about other platforms, see the relevant *Dell EMC Networking OS Command Line Reference Guide*.

Version	Description
9.11(0.0)	Introduced on the M I/O Aggregator and FN IOM.
9.10(0.1)	Introduced on the S6010-ON and S4048T-ON.
9.10(0.0)	Introduced on the S3148.
9.10(0.0)	Introduced on the C9010, Z9100-ON, S6100-ON, and S3100 series.
9.9(0.0)	Introduced on the S4810, S4820T, S3048-ON, S4048-ON, S5000, S6000, S6000-ON, Z9500, MXL.

**Usage Information** You are guided through a series of queries to configure SupportAssist. The generated commands are added to the running configuration, including the DNS resolve commands, if configured.

This command starts the configuration wizard for the SupportAssist. At any time, you can exit by entering Ctrl-C. If necessary, you can skip some data entry.

Once you exit the wizard, the Dell EMC Networking OS starts a full transfer.

# support-assist activity

Trigger an activity event immediately.

**Syntax** `support-assist activity {full-transfer | core-transfer} start now`

**Parameters**

<b>full-transfer</b>	Enter the keyword <code>full-transfer</code> to specify transfer of configuration, inventory, logs, and other information.
<b>core-transfer</b>	Enter the keyword <code>core-transfer</code> to specify transfer of core files.

**Command Modes** EXEC Privilege

**Command History** This guide is platform-specific. For command information about other platforms, see the relevant *Dell EMC Networking OS Command Line Reference Guide*.

Version	Description
9.11(0.0)	Introduced on the M I/O Aggregator and FN IOM.
9.10(0.1)	Introduced on the S6010-ON and S4048T-ON.
9.10(0.0)	Introduced on the S3148.
9.10(0.0)	Introduced on the C9010, Z9100-ON, S6100-ON, and S3100 series.
9.9(0.0)	Introduced on the S4810, S4820T, S3048-ON, S4048-ON, S5000, S6000, S6000-ON, Z9500, MXL.

**Usage Information** Use the command to trigger the activity that enables transfer of information. You can choose a full transfer that includes all the details or core transfer that includes only the core files.

 **NOTE:** The full transfer includes the core files as well in the information sent. The core transfer does not send core files that are older than 30 days.

## SupportAssist Commands

Dell EMC Networking OS supports the following SupportAssist mode commands.

### activity

Move to the SupportAssist Activity mode for an activity. Allow the user to configure customized details for a specific activity.

**Syntax** `activity {activity-name}`

To remove all customized detail for a specific activity, use the `no activity {activity-name}` command.

**Parameters**

<b>activity-name</b>	Enter one of the following keywords:
----------------------	--------------------------------------

- Enter the keyword `full-transfer` to enable or disable full transfer. You can create a custom file to transfer the outputs from a set of show commands. By default, the full transfer runs once in every 30 days.
- Enter the keyword `core-transfer` to enable or disable core transfer.
- Enter the keyword `event-transfer` to enable or disable event transfer. You can create a custom file to monitor a set of events.

**Command Modes** SUPPORTASSIST

**Command History** This guide is platform-specific. For command information about other platforms, see the relevant *Dell EMC Networking OS Command Line Reference Guide*.

Version	Description
9.11(0.0)	Introduced on the M I/O Aggregator and FN IOM. Introduced the <code>core-transfer</code> and <code>event-transfer</code> parameters.
9.10(0.1)	Introduced on the S6010-ON and S4048T-ON.
9.10(0.0)	Introduced on the S3148.
9.10(0.0)	Introduced on the C9010, Z9100-ON, S6100-ON, and S3100 series.
9.9(0.0)	Introduced on the S4810, S4820T, S3048-ON, S4048-ON, S5000, S6000, S6000-ON, Z9500, MXL.

#### Usage Information

By default, each activity follows a set of default actions using a default schedule. Using this command, you can customize the set of actions and disable a certain activity.

## contact-company

Configure the contact information for the company.

**Syntax** `contact-company name {company-name} [company-next-name] ... [company-next-name]`

To remove the contact company information, use the `no contact-company` command.

#### Parameters

<b><i>company-name</i></b>	Enter the name for the company. If there are multiple words in the name, use optional additional fields.
<b><i>company-next-name</i></b>	(OPTIONAL) Enter the next components of the company name, up to 5 components are allowed.

**Command Modes** SUPPORTASSIST

#### Command History

This guide is platform-specific. For command information about other platforms, see the relevant *Dell EMC Networking OS Command Line Reference Guide*.

Version	Description
9.11(0.0)	Introduced on the M I/O Aggregator and FN IOM.
9.10(0.1)	Introduced on the S6010-ON and S4048T-ON.
9.10(0.0)	Introduced on the S3148.
9.10(0.0)	Introduced on the C9010, Z9100-ON, S6100-ON, and S3100 series.
9.9(0.0)	Introduced on the S4810, S4820T, S3048-ON, S4048-ON, S5000, S6000, S6000-ON, Z9500, MXL.

#### Usage Information

You can configure only one contact-company.

It is not possible to remove the components of the company name. The `no` form of the command removes the entire contact-company entry.

This command is optional for SupportAssist service configuration.

## contact-person

Configure the contact name for an individual.

**Syntax** `contact-person [first <first-name>] last <last-name>`

To remove the contact person and all their details, use the `no contact-person [first <first-name>] last <last-name>` command.



<b>Parameters</b>	<b><i>first-name</i></b>	(Optional) Enter the first name for the contact person. This is optional provided each contact person name is unique. To include a space, enter a space within double quotes.
	<b><i>last-name</i></b>	Enter the last name for the contact person. To include a space, enter a space within double quotes.

**Command Modes** SUPPORTASSIST

**Command History** This guide is platform-specific. For command information about other platforms, see the relevant *Dell EMC Networking OS Command Line Reference Guide*.

<b>Version</b>	<b>Description</b>
<b>9.11(0.0)</b>	Introduced on the M I/O Aggregator and FN IOM.
<b>9.10(0.1)</b>	Introduced on the S6010-ON and S4048T-ON.
<b>9.10(0.0)</b>	Introduced on the S3148.
<b>9.10(0.0)</b>	Introduced on the C9010, Z9100-ON, S6100-ON, and S3100 series.
<b>9.9(0.0)</b>	Introduced on the S4810, S4820T, S3048-ON, S4048-ON, S5000, S6000, S6000-ON, Z9500, MXL.

**Usage Information**

Each contact person must be unique by their name.

You can configure only one contact person.

It is not possible to remove the first name or last name. The no form of the command removes the entire contact-person entry.

This command is optional for SupportAssist service configuration.

## enable

Enable all activities and severs for the SupportAssist service.

**Syntax** `enable all`

To disable the SupportAssist activities temporarily, use the `no enable all` command.

**Parameters** **all** Enter the keyword `all` to enable all SupportAssist service activities.

**Defaults** Enabled or All Enabled

**Command Modes** SUPPORTASSIST

**Command History** This guide is platform-specific. For command information about other platforms, see the relevant *Dell EMC Networking OS Command Line Reference Guide*.

<b>Version</b>	<b>Description</b>
<b>9.11(0.0)</b>	Introduced on the M I/O Aggregator and FN IOM.
<b>9.10(0.1)</b>	Introduced on the S6010-ON and S4048T-ON.
<b>9.10(0.0)</b>	Introduced on the S3148.
<b>9.10(0.0)</b>	Introduced on the C9010, Z9100-ON, S6100-ON, and S3100 series.
<b>9.9(0.0)</b>	Introduced on the S4810, S4820T, S3048-ON, S4048-ON, S5000, S6000, S6000-ON, Z9500, MXL.

## server

Configure the name of the remote SupportAssist Server and move to SupportAssist Server mode.

**Syntax** `server {default | server-name}`

To delete a server, use the `no server server-name` command.

**Parameters**

<b>default</b>	Enter the keyword <code>default</code> for the default server.
<b>server-name</b>	Enter the name of the custom server to which the logs would be transferred. To include a space, enter a space within double quotes.

**Defaults** Default server has URL `stor.g3.ph.dell.com`

**Command Modes** SUPPORTASSIST

**Command History** This guide is platform-specific. For command information about other platforms, see the relevant *Dell EMC Networking OS Command Line Reference Guide*.

Version	Description
9.11(0.0)	Introduced on the M I/O Aggregator and FN IOM.
9.10(0.1)	Introduced on the S6010-ON and S4048T-ON.
9.10(0.0)	Introduced on the S3148.
9.10(0.0)	Introduced on the C9010, Z9100-ON, S6100-ON, and S3100 series.
9.9(0.0)	Introduced on the S4810, S4820T, S3048-ON, S4048-ON, S5000, S6000, S6000-ON, Z9500, MXL.

**Usage Information** The `server-name` is used as a reference only and is not required to be used as part of a URL definition. There is a reserved name of `default` for the default server at `stor.g3.ph.dell.com`. You can customize the defaults for this server by entering the `server default` command and use the custom commands. You can configure one additional server.

## SupportAssist Activity Commands

Dell EMC Networking OS supports the following SupportAssist Activity mode commands.

### action-manifest get

Copy an action-manifest file for an activity to the system.

**Syntax** `action-manifest get tftp | ftp | flash <file-specification> <local-file-name>`

**Parameters**

<b>file-specification</b>	Enter the full file specification for the action-manifest file. For example: <ul style="list-style-type: none"><li>• <code>tftp://hostip/filepath</code></li><li>• <code>ftp://userid:password@hostip/filepath</code></li><li>• <code>scp://userid:password@hostip/filepath</code></li></ul>
<b>local-file-name</b>	Enter the name of the local action-manifest file, up to 32 characters long. Allowable characters are: a to z, A to Z, 0 to 9, -, _, and space.

**Command Modes** SUPPORTASSIST ACTIVITY FULL-TRANSFER  
SUPPORTASSIST ACTIVITY EVENT-TRANSFER

## Command History

This guide is platform-specific. For command information about other platforms, see the relevant *Dell EMC Networking OS Command Line Reference Guide*.

Version	Description
9.11(0.0)	Introduced on the M I/O Aggregator and FN IOM.
9.10(0.1)	Introduced on the S6010-ON and S4048T-ON.
9.10(0.0)	Introduced on the S3148.
9.10(0.0)	Introduced on the C9010, Z9100-ON, S6100-ON, and S3100 series.
9.9(0.0)	Introduced on the S4810, S4820T, S3048-ON, S4048-ON, S5000, S6000, S6000-ON, Z9500, MXL.

## Usage Information

The remote file specification for full transfer includes the protocol that is used to copy the file from the remote system.

The default Manifest-file for full transfer includes records like alarms, logs, operational, and configuration data.

## Related Commands

- [action-manifest install](#) — configure the action-manifest to use for a specific activity.
- [action-manifest show](#) — view the list of action-manifest for a specific activity.
- [action-manifest remove](#) — remove the action-manifest file for an activity.

# action-manifest install

Configure action-manifest to transfer a set of customized records for full transfer and to monitor a set of specified events for event transfer.

## Syntax

```
action-manifest install {default | <local-file-name>}
```

To revert to the default action-manifest file, use the `action-manifest install default` command.

## Parameters

<b>default</b>	Enter the keyword <code>default</code> to revert back to the default set of actions for an activity.
<b>local-file-name</b>	Enter the name of the local action-manifest file. Allowable characters are: a to z, A to Z, 0 to 9, -, _, and space.

## Defaults

Default

## Command Modes

SUPPORTASSIST ACTIVITY FULL-TRANSFER  
SUPPORTASSIST ACTIVITY EVENT-TRANSFER

## Command History

This guide is platform-specific. For command information about other platforms, see the relevant *Dell EMC Networking OS Command Line Reference Guide*.

Version	Description
9.11(0.0)	Introduced on the M I/O Aggregator and FN IOM.
9.10(0.1)	Introduced on the S6010-ON and S4048T-ON.
9.10(0.0)	Introduced on the S3148.
9.10(0.0)	Introduced on the C9010, Z9100-ON, S6100-ON, and S3100 series.
9.9(0.0)	Introduced on the S4810, S4820T, S3048-ON, S4048-ON, S5000, S6000, S6000-ON, Z9500, MXL.

## Usage Information

To replace the default action-manifest with a customized one, copy the action-manifest file to the system using the `action-manifest get` command and then use the `action-manifest install` command. To revert to the default action-manifest file, use the `action-manifest install default` command.

- Related Commands**
- [action-manifest get](#) — copy an action-manifest file for an activity to the system.
  - [action-manifest show](#) — view the list of action-manifest for a specific activity.
  - [action-manifest remove](#) — remove the action-manifest file for an activity.

## action-manifest remove

Remove the action-manifest file from Dell EMC Networking OS.

<b>Syntax</b>	<code>action-manifest remove &lt;local-file-name&gt;</code>
<b>Parameters</b>	<b>local-file-name</b> Enter the name of the local action-manifest file. Allowable characters are: a to z, A to Z, 0 to 9, -, _, and space.
<b>Command Modes</b>	SUPPORTASSIST ACTIVITY FULL-TRANSFER SUPPORTASSIST ACTIVITY EVENT-TRANSFER
<b>Command History</b>	This guide is platform-specific. For command information about other platforms, see the relevant <i>Dell EMC Networking OS Command Line Reference Guide</i> .

Version	Description
<b>9.11(0.0)</b>	Introduced on the M I/O Aggregator and FN IOM.
<b>9.10(0.1)</b>	Introduced on the S6010-ON and S4048T-ON.
<b>9.10(0.0)</b>	Introduced on the S3148.
<b>9.10(0.0)</b>	Introduced on the C9010, Z9100-ON, S6100-ON, and S3100 series.
<b>9.9(0.0)</b>	Introduced on the S4810, S4820T, S3048-ON, S4048-ON, S5000, S6000, S6000-ON, Z9500, MXL.

- Usage Information**
- To revert to the default action-manifest file, use the `action-manifest install` command. If necessary, you can then remove the custom action-manifest file.
- Related Commands**
- [action-manifest get](#) — copy an action-manifest file for an activity to the system.
  - [action-manifest install](#) — configure the action-manifest to use for a specific activity.
  - [action-manifest show](#) — view the list of action-manifest for a specific activity.

## action-manifest show

View the list of action-manifest for a specific activity.

<b>Syntax</b>	<code>action-manifest show {all}</code>
<b>Parameters</b>	<b>all</b> Enter the keyword <code>all</code> to view the entire list of action-manifests that are available for an activity.
<b>Command Modes</b>	SUPPORTASSIST ACTIVITY FULL-TRANSFER SUPPORTASSIST ACTIVITY EVENT-TRANSFER
<b>Command History</b>	This guide is platform-specific. For command information about other platforms, see the relevant <i>Dell EMC Networking OS Command Line Reference Guide</i> .

Version	Description
<b>9.11(0.0)</b>	Introduced on the M I/O Aggregator and FN IOM.
<b>9.10(0.1)</b>	Introduced on the S6010-ON and S4048T-ON.
<b>9.10(0.0)</b>	Introduced on the S3148.
<b>9.10(0.0)</b>	Introduced on the C9010, Z9100-ON, S6100-ON, and S3100 series.

Version	Description
9.9(0.0)	Introduced on the S4810, S4820T, S3048-ON, S4048-ON, S5000, S6000, S6000-ON, Z9500, MXL.

#### Related Commands

- [action-manifest get](#) — copy an action-manifest file for an activity to the system.
- [action-manifest install](#) — configure the action-manifest to use for a specific activity.
- [action-manifest remove](#) — remove the action-manifest file for an activity.

## enable

Enable a specific SupportAssist activity.

#### Syntax

`enable`

To disable a particular SupportAssist activity, use the `no enable` command.

#### Defaults

Enabled

#### Command Modes

SUPPORTASSIST ACTIVITY FULL-TRANSFER  
 SUPPORTASSIST ACTIVITY CORE-TRANSFER  
 SUPPORTASSIST ACTIVITY EVENT-TRANSFER

#### Command History

This guide is platform-specific. For command information about other platforms, see the relevant *Dell EMC Networking OS Command Line Reference Guide*.

Version	Description
9.11(0.0)	Introduced on the M I/O Aggregator and FN IOM.
9.10(0.1)	Introduced on the S6010-ON and S4048T-ON.
9.10(0.0)	Introduced on the S3148.
9.10(0.0)	Introduced on the C9010, Z9100-ON, S6100-ON, and S3100 series.
9.9(0.0)	Introduced on the S4810, S4820T, S3048-ON, S4048-ON, S5000, S6000, S6000-ON, Z9500, MXL.

#### Usage Information

Enter the specific SupportAssist activity mode and then enable it.

**NOTE:** By default, the full transfer includes the core files. When you disable the core transfer activity, the full transfer excludes the core files.

#### Related Commands

- [activity](#) — move user to the SupportAssist Activity mode for that activity.

## SupportAssist Company Commands

Dell EMC Networking OS supports the following SupportAssist Company mode commands.

### address

Configure the address information for the company.

#### Syntax

`address [city company-city] [{province | region | state} name] [country company-country] [{postalcode | zipcode} company-code]`

To remove a portion of the company address information, use the `no address [city | province | region | state | country | postalcode | zipcode]` command. For example, to remove the city alone, use the `no address city` command.

To remove the complete company contact information, use the `no address` command.

## Parameters

<b>city</b> <i>company-city</i>	(OPTIONAL) Enter the keyword <code>city</code> then the city or town for the company site. To include a space, enter a space within double quotes.
<b>province   region   state</b> <i>name</i>	(OPTIONAL) Enter the keyword <code>province</code> , <code>region</code> or <code>state</code> then the name of province, region or state for the company site. To include a space, enter a space within double quotes.
<b>country</b> <i>company-country</i>	(OPTIONAL) Enter the keyword <code>country</code> then the country for the company site. To include a space, enter a space within double quotes.
<b>postalcode   zipcode</b> <i>company-code</i>	(OPTIONAL) Enter the keyword <code>postalcode</code> or <code>zipcode</code> then the postal code or zip code for the company site, as one string with no spaces.

**Command Modes** SUPPORTASSIST COMPANY

## Command History

This guide is platform-specific. For command information about other platforms, see the relevant *Dell EMC Networking OS Command Line Reference Guide*.

Version	Description
9.11(0.0)	Introduced on the M I/O Aggregator and FN IOM.
9.10(0.1)	Introduced on the S6010-ON and S4048T-ON.
9.10(0.0)	Introduced on the S3148.
9.10(0.0)	Introduced on the C9010, Z9100-ON, S6100-ON, and S3100 series.
9.9(0.0)	Introduced on the S4810, S4820T, S3048-ON, S4048-ON, S5000, S6000, S6000-ON, Z9500, MXL.

## Usage Information

The optional parameters must be provided in the following order: `city state country postalcode`. If specified in a different order, the command returns an error as follows:

```
DellEMC(conf-supportassist-cmpy-test)# address city Minneapolis
postalcode 55344 country USA state Minnesota
                                     ^
% Error: Invalid input at "^" marker.
```

This command is optional for SupportAssist service configuration.

## Example

```
DellEMC(conf-supportassist-cmpy-test)# address city Minneapolis state
Minnesota country USA postalcode 55344
```

# street-address

Configure the street address information for the company.

## Syntax

```
street-address {address1} [address2]...[address8]
```

To remove the street address, use the `no street-address` command.

## Parameters

<b>address1</b>	Enter the street address for the company.
<b>address2..address8</b>	(OPTIONAL) Enter the street address of the company site. Up to 8 fields are allowed.

**Command Modes** SUPPORTASSIST COMPANY

## Command History

This guide is platform-specific. For command information about other platforms, see the relevant *Dell EMC Networking OS Command Line Reference Guide*.

Version	Description
9.11(0.0)	Introduced on the M I/O Aggregator and FN IOM.
9.10(0.1)	Introduced on the S6010-ON and S4048T-ON.
9.10(0.0)	Introduced on the S3148.
9.10(0.0)	Introduced on the C9010, Z9100-ON, S6100-ON, and S3100 series.
9.9(0.0)	Introduced on the S4810, S4820T, S3048-ON, S4048-ON, S5000, S6000, S6000-ON, Z9500, MXL.

**Usage Information** This command is optional for SupportAssist service configuration.

## territory

Configure the territory and set the coverage for the company site.

**Syntax** `territory company-territory`  
To remove the company territory information, use the `no territory` command.

**Parameters** **company-territory** Enter the territory name for the company. To include a space, enter a space within double quotes. Use three-letter country codes like USA, IND, FRA, GER and so on.

**Command Modes** SUPPORTASSIST COMPANY

**Command History** This guide is platform-specific. For command information about other platforms, see the relevant *Dell EMC Networking OS Command Line Reference Guide*.

Version	Description
9.11(0.0)	Introduced on the M I/O Aggregator and FN IOM.
9.10(0.1)	Introduced on the S6010-ON and S4048T-ON.
9.10(0.0)	Introduced on the S3148.
9.10(0.0)	Introduced on the C9010, Z9100-ON, S6100-ON, and S3100 series.
9.9(0.0)	Introduced on the S4810, S4820T, S3048-ON, S4048-ON, S5000, S6000, S6000-ON, Z9500, MXL.

**Usage Information** This command is optional for SupportAssist service configuration.

## SupportAssist Person Commands

Dell EMC Networking OS supports the following SupportAssist Person mode commands.

### email-address

Configure the email addresses to reach the contact person.

**Syntax** `email-address primary email-address [alternate email-address]`  
To remove an email address, use the `no email-address` command. To remove the primary and the alternate email addresses, use the `no email-address primary` and `no email-address alternate` commands respectively.

<b>Parameters</b>	<b>primary <i>email-address</i></b>	Enter the keyword <code>primary</code> then the primary email address for the person.
	<b>alternate <i>email-address</i></b>	Enter the keyword <code>alternate</code> then the alternate email address for the person.

**Command Modes** SUPPORTASSIST PERSON

**Command History** This guide is platform-specific. For command information about other platforms, see the relevant *Dell EMC Networking OS Command Line Reference Guide*.

<b>Version</b>	<b>Description</b>
<b>9.11(0.0)</b>	Introduced on the M I/O Aggregator and FN IOM.
<b>9.10(0.1)</b>	Introduced on the S6010-ON and S4048T-ON.
<b>9.10(0.0)</b>	Introduced on the S3148.
<b>9.10(0.0)</b>	Introduced on the C9010, Z9100-ON, S6100-ON, and S3100 series.
<b>9.9(0.0)</b>	Introduced on the S4810, S4820T, S3048-ON, S4048-ON, S5000, S6000, S6000-ON, Z9500, MXL.

**Usage Information** The email addresses must have the standard form of `<username>@<email system>` to be considered valid.

This command is optional for SupportAssist service configuration.

**Related Commands**

- [preferred-method](#) — configure the preferred method for contacting the person.

## phone

Configure phone numbers to reach the contact person.

**Syntax** `phone primary phone [alternate phone]`

To remove a phone number, use the `no phone` command. To remove the primary and alternate phone numbers, use the `no phone primary` and `no phone alternate` commands respectively.

<b>Parameters</b>	<b>primary <i>phone</i></b>	Enter the keyword <code>primary</code> then the primary phone number for the person.
	<b>alternate <i>phone</i></b>	Enter the keyword <code>alternate</code> then the alternate phone number for the person.

**Command Modes** SUPPORTASSIST PERSON

**Command History** This guide is platform-specific. For command information about other platforms, see the relevant *Dell EMC Networking OS Command Line Reference Guide*.

<b>Version</b>	<b>Description</b>
<b>9.11(0.0)</b>	Introduced on the M I/O Aggregator and FN IOM.
<b>9.10(0.1)</b>	Introduced on the S6010-ON and S4048T-ON.
<b>9.10(0.0)</b>	Introduced on the S3148.
<b>9.10(0.0)</b>	Introduced on the C9010, Z9100-ON, S6100-ON, and S3100 series.
<b>9.9(0.0)</b>	Introduced on the S4810, S4820T, S3048-ON, S4048-ON, S5000, S6000, S6000-ON, Z9500, MXL.

**Usage Information** The phone numbers may contain country codes, area codes and extensions, if necessary. Allowable characters are 0 to 9, x, (, ), - and +.

This command is optional for SupportAssist service configuration.



## Related Commands

- [preferred-method](#) — configure the preferred method for contacting the person.

# preferred-method

Configure the preferred method for contacting the person.

**Syntax** `preferred-method {email | no-contact | phone}`

**Parameters**

<b>email</b>	Enter the keyword <code>email</code> to specify email as preferred method.
<b>no-contact</b>	Enter the keywords <code>no-contact</code> to specify that there is no preferred method.
<b>phone</b>	Enter the keyword <code>phone</code> to specify phone as preferred method.

**Defaults** `no-contact`

**Command Modes** `SUPPORTASSIST PERSON`

**Command History** This guide is platform-specific. For command information about other platforms, see the relevant *Dell EMC Networking OS Command Line Reference Guide*.

Version	Description
<b>9.11(0.0)</b>	Introduced on the M I/O Aggregator and FN IOM.
<b>9.10(0.1)</b>	Introduced on the S6010-ON and S4048T-ON.
<b>9.10(0.0)</b>	Introduced on the S3148.
<b>9.10(0.0)</b>	Introduced on the C9010, Z9100-ON, S6100-ON, and S3100 series.
<b>9.9(0.0)</b>	Introduced on the S4810, S4820T, S3048-ON, S4048-ON, S5000, S6000, S6000-ON, Z9500, MXL.

## Related Commands

- [email-address](#) — configure email addresses to reach the contact person.
- [phone](#) — configure phone numbers to reach the contact person.

# time-zone

Configure the time zone for contacting the person.

**Syntax** `time-zone zone +-HH:MM[start-time HH:MM] [end-time HH:MM]`

To remove the time zone, use the `no time-zone [zone | start-time | end-time]` command.

**Parameters**

<b>zone +-HH:MM</b>	Enter the keyword <code>zone</code> then a time difference from GMT expressed as HH:MM. This number may be preceded by either a + or – sign.
<b>start-time HH:MM</b>	Enter the keywords <code>start-time</code> then a starting time expressed as HH:MM. Use the 24-hour clock format.
<b>stop-time HH:MM</b>	Enter the keywords <code>stop-time</code> then a stopping time expressed as HH:MM. Use the 24-hour clock format.

**Command Modes** `SUPPORTASSIST PERSON`

**Command History** This guide is platform-specific. For command information about other platforms, see the relevant *Dell EMC Networking OS Command Line Reference Guide*.

Version	Description
<b>9.11(0.0)</b>	Introduced on the M I/O Aggregator and FN IOM.
<b>9.10(0.1)</b>	Introduced on the S6010-ON and S4048T-ON.
<b>9.10(0.0)</b>	Introduced on the S3148.

Version	Description
9.10(0.0)	Introduced on the C9010, Z9100-ON, S6100-ON, and S3100 series.
9.9(0.0)	Introduced on the S4810, S4820T, S3048-ON, S4048-ON, S5000, S6000, S6000-ON, Z9500, MXL.

### Usage Information

This command is optional for SupportAssist service configuration.

## SupportAssist Server Commands

Dell EMC Networking OS supports the following SupportAssist Server mode commands.

### proxy-ip-address

Configure a proxy for reaching the SupportAssist remote server.

**Syntax** `proxy-ip-address {ipv4-address | ipv6-address} port port-number [ username userid password [ encryption-type] password ]`

To remove the proxy, use the `no proxy-ip-address` command.

### Parameters

<b>ipv4-address</b>	Enter the IP address of the proxy server in a dotted decimal format (A.B.C.D).
<b>ipv6-address</b>	Enter the IPv6 address of the proxy server in the x:x:x:x format. <i>i</i> <b>NOTE:</b> The :: notation specifies successive hexadecimal fields of zeros.
	<i>i</i> <b>NOTE:</b> To use the IPv6 address, the Open Automation package should also support IPv6 communications. For this purpose, SupportAssist requires Dell EMC Networking Open Automation 9.10(0.0) package or later.
<b>port port-number</b>	Enter the keyword <code>port</code> then the TCP/IP port number. The port number range is from 1024 to 65534.
<b>username userid</b>	(OPTIONAL) Enter the keyword <code>username</code> then the user ID used for the proxy server.
<b>password</b>	Enter the keyword <code>password</code> then the encryption-type or the user password.
<b>encryption-type</b>	(OPTIONAL) Enter an encryption type for the <code>password</code> you enter. <ul style="list-style-type: none"> <li>0 directs the system to interpret the password as clear text.</li> <li>7 indicates that the password is encrypted using a DES hashing algorithm.</li> </ul>
<b>password</b>	Enter a string up to 32 characters long.

**Defaults** encryption-type for the password is 0.

**Command Modes** SUPPORTASSIST SERVER

**Command History** This guide is platform-specific. For command information about other platforms, see the relevant *Dell EMC Networking OS Command Line Reference Guide*.

Version	Description
9.11(0.0)	Introduced on the M I/O Aggregator and FN IOM.
9.10(0.1)	Introduced on the S6010-ON and S4048T-ON.
9.10(0.0)	Introduced on the S3148.
9.10(0.0)	Introduced on the C9010, Z9100-ON, S6100-ON, and S3100 series.
9.9(0.0)	Introduced on the S4810, S4820T, S3048-ON, S4048-ON, S5000, S6000, S6000-ON, Z9500, MXL.

## Usage Information

The passwords are stored encrypted in the running configuration.

## enable

Enable communication with the SupportAssist server.

**Syntax** `enable`

To disable communication to a specific SupportAssist server, use the `no enable` command.

**Defaults** Enabled

**Command Modes** SUPPORTASSIST SERVER

**Command History** This guide is platform-specific. For command information about other platforms, see the relevant *Dell EMC Networking OS Command Line Reference Guide*.

Version	Description
9.11(0.0)	Introduced on the M I/O Aggregator and FN IOM.
9.10(0.1)	Introduced on the S6010-ON and S4048T-ON.
9.10(0.0)	Introduced on the S3148.
9.10(0.0)	Introduced on the C9010, Z9100-ON, S6100-ON, and S3100 series.
9.9(0.0)	Introduced on the S4810, S4820T, S3048-ON, S4048-ON, S5000, S6000, S6000-ON, Z9500, MXL.

## Related Commands

- `server` — configure the name of the remote SupportAssist server.

## url

Configure the URL to reach the SupportAssist remote server.

**Syntax** `url uniform-resource-locator`

To delete the URL for the server, use the `no url` command.

## Parameters

### *uniform-resource-locator*

Enter a text string for the URL using one of the following formats:

- `http://[username:password@]<hostip>:<portNum>/<filepath>`
- `https://[username:password@]<hostip>:<portNum>/<filepath>`

 **NOTE:** The host IP for the server may be specified as an IPv4 address, an IPv6 address or as a DNS hostname. If using the DNS hostname, the DNS resolver will need to be configured and enabled.

**Command Modes** SUPPORTASSIST SERVER

**Command History** This guide is platform-specific. For command information about other platforms, see the relevant *Dell EMC Networking OS Command Line Reference Guide*.

Version	Description
9.11(0.0)	Introduced on the M I/O Aggregator and FN IOM.
9.10(0.1)	Introduced on the S6010-ON and S4048T-ON.
9.10(0.0)	Introduced on the S3148.
9.10(0.0)	Introduced on the C9010, Z9100-ON, S6100-ON, and S3100 series.
9.9(0.0)	Introduced on the S4810, S4820T, S3048-ON, S4048-ON, S5000, S6000, S6000-ON, Z9500, MXL.

## Usage Information

The URL should be formatted to follow the ISO format.

# show eula-consent

Display the EULA for the feature.

**Syntax** `show eula-consent {support-assist | other feature}`

**Parameters** **support-assist | other feature** Enter the keywords `support-assist` or the text corresponding to other feature.

**Command Modes** EXEC Privilege

**Command History** This guide is platform-specific. For command information about other platforms, see the relevant *Dell EMC Networking OS Command Line Reference Guide*.

Version	Description
9.11(0.0)	Introduced on the M I/O Aggregator and FN IOM.
9.10(0.1)	Introduced on the S6010-ON and S4048T-ON.
9.10(0.0)	Introduced on the S3148.
9.10(0.0)	Introduced on the C9010, Z9100-ON, S6100-ON, and S3100 series.
9.9(0.0)	Introduced on the S4810, S4820T, S3048-ON, S4048-ON, S5000, S6000, S6000-ON, Z9500, MXL.

## Example

```
DellEMC# show eula-consent support-assist

SupportAssist EULA has been: Accepted

Additional information about the SupportAssist EULA is as follows:

By installing SupportAssist, you allow Dell to save your contact
information
(e.g. name, phone number and/or email address) which would be used to
provide
technical support for your Dell products and services. Dell may use the
information
for providing recommendations to improve your IT infrastructure.

Dell SupportAssist also collects and stores machine diagnostic
information, which
may include but is not limited to configuration information, user
supplied contact
information, names of data volumes, IP addresses, access control lists,
diagnostics &
performance information, network configuration information, host/server
configuration
& performance information and related data (Collected Data) and
transmits this
information to Dell. By downloading SupportAssist and agreeing to be
bound by these
terms and the Dell end user license agreement, available at:
www.dell.com/aeula,
you agree to allow Dell to provide remote monitoring services of your IT
environment
and you give Dell the right to collect the Collected Data in accordance
with Dells
Privacy Policy, available at: www.dell.com/privacypolicycountryspecific,
in order to
enable the performance of all of the various functions of SupportAssist
during your
entitlement to receive related repair services from Dell,. You further
agree to
```

```

allow Dell to transmit and store the Collected Data from SupportAssist
in accordance
with these terms. You agree that the provision of SupportAssist may
involve
international transfers of data from you to Dell and/or to Dells
affiliates,
subcontractors or business partners. When making such transfers, Dell
shall ensure
appropriate protection is in place to safeguard the Collected Data being
transferred
in connection with SupportAssist. If you are downloading SupportAssist
on behalf
of a company or other legal entity, you are further certifying to Dell
that you
have appropriate authority to provide this consent on behalf of that
entity. If you
do not consent to the collection, transmission and/or use of the
Collected Data,
you may not download, install or otherwise use SupportAssist.
DellEMC#

```

## show running-config

Display the current configuration and changes from the default values.

**Syntax** `show running-config support-assist`

**Parameters** **support-assist** Enter the keyword `support-assist` to view the detailed configuration for the feature.

**Command Modes** EXEC Privilege

**Command History** This guide is platform-specific. For command information about other platforms, see the relevant *Dell EMC Networking OS Command Line Reference Guide*.

Version	Description
9.11(0.0)	Introduced on the M I/O Aggregator and FN IOM.
9.10(0.1)	Introduced on the S6010-ON and S4048T-ON.
9.10(0.0)	Introduced on the S3148.
9.10(0.0)	Introduced on the C9010, Z9100-ON, S6100-ON, and S3100 series.
9.9(0.0)	Introduced on the S4810, S4820T, S3048-ON, S4048-ON, S5000, S6000, S6000-ON, Z9500, MXL.

### Example

```

DellEMC# show running-config support-assist
!
support-assist
enable all
!
activity event-transfer
enable
action-manifest install default
!
activity core-transfer
enable
!
contact-company name Dell
street-address F lane , Sector 30
address city Brussels state HeadState country Belgium postalcode S328J3
!
contact-person first Fred last Nash
email-address primary des@sed.com alternate sed@dol.com
phone primary 123422 alternate 8395729

```

```

preferred-method email
time-zone zone +05:30 start-time 12:23 end-time 15:23
!
server Dell
  enable
  url http://1.1.1.1:1332
DellEMC#

```

## show support-assist status

Display information on SupportAssist feature status including any activities, status of communication, last time communication sent, and so on.

**Syntax** `show support-assist status`

**Command Modes** EXEC Privilege

**Command History** This guide is platform-specific. For command information about other platforms, see the relevant *Dell EMC Networking OS Command Line Reference Guide*.

Version	Description
9.11(0.0)	Introduced on the M I/O Aggregator and FN IOM.
9.10(0.1)	Introduced on the S6010-ON and S4048T-ON.
9.10(0.0)	Introduced on the S3148.
9.10(0.0)	Introduced on the C9010, Z9100-ON, S6100-ON, and S3100 series.
9.9(0.0)	Introduced on the S4810, S4820T, S3048-ON, S4048-ON, S5000, S6000, S6000-ON, Z9500, MXL.

### Example

```

DellEMC#show support-assist status
SupportAssist Service: Installed
EULA: Accepted
Server: default
  Enabled: Yes
  URL: https://stor.g3.ph.dell.com
Server: Dell
  Enabled: Yes
  URL: http://1.1.1.1:1332
Service status: Enabled

```

Activity	State	Last Start	Last Success
core-transfer 2016 09:43:56 IST	Success	Feb 15 2016 09:43:41 IST	Feb 15
event-transfer 2016 09:48:21 IST	Success	Feb 15 2016 09:47:43 IST	Feb 15
full-transfer 2016 09:38:27 IST	Success	Feb 15 2016 09:36:12 IST	Feb 15

```

DellEMC#

```

# System Time

The commands in this chapter configure time values on the system, either using the Dell Networking OS, the hardware, or using the network time protocol (NTP). With NTP, the switch can act only as a client to an NTP clock host.

For more information, refer to the **Network Time Protocol** section of the *Management* chapter in the *Dell Networking OS Configuration Guide*.

The NTP commands are:

- [calendar set](#)
- [ntp server](#)
- [show calendar](#)
- [show clock](#)
- [clock read-calendar](#)
- [clock set](#)
- [clock summer-time date](#)
- [clock summer-time recurring](#)
- [clock timezone](#)
- [clock update-calendar](#)

## Topics:

- [calendar set](#)
- [clock read-calendar](#)
- [clock set](#)
- [clock summer-time date](#)
- [clock summer-time recurring](#)
- [clock timezone](#)
- [clock update-calendar](#)
- [ntp control-key-passwd](#)
- [ntp server](#)
- [show calendar](#)
- [show clock](#)

## calendar set

Set the time and date for the switch hardware clock.

**Syntax** `calendar set time month day year`

<b>Parameters</b>	<b><i>time</i></b>	Enter the time in hours:minutes:seconds. For the hour variable, use the 24-hour format; for example, 17:15:00 is 5:15 pm.
	<b><i>month</i></b>	Enter the name of one of the 12 months in English. You can enter the name of a day to change the order of the display to time day month year.
	<b><i>day</i></b>	Enter the number of the day. The range is from 1 to 31. You can enter the name of a month to change the order of the display to <i>time day month year</i> .
	<b><i>year</i></b>	Enter a four-digit number as the year. The range is from 1993 to 2035.

**Command Modes** EXEC Privilege

**Supported Modes** All Modes

<b>Command History</b>	<table border="0"> <thead> <tr> <th style="text-align: left;"><b>Version</b></th> <th style="text-align: left;"><b>Description</b></th> </tr> </thead> <tbody> <tr> <td><b>9.4(0.0)</b></td> <td>Supported on the FN I/O Aggregator.</td> </tr> <tr> <td><b>8.3.17.0</b></td> <td>Supported on the M I/O Aggregator.</td> </tr> </tbody> </table>	<b>Version</b>	<b>Description</b>	<b>9.4(0.0)</b>	Supported on the FN I/O Aggregator.	<b>8.3.17.0</b>	Supported on the M I/O Aggregator.
<b>Version</b>	<b>Description</b>						
<b>9.4(0.0)</b>	Supported on the FN I/O Aggregator.						
<b>8.3.17.0</b>	Supported on the M I/O Aggregator.						
<b>Usage Information</b>	<p>You can change the order of the month and day parameters to enter the time and date as time day month year.</p> <p>In the switch, the hardware clock is separate from the software and is called the calendar. This hardware clock runs continuously. After the hardware clock (the calendar) is set, the operating system automatically updates the software clock after system bootup. You cannot delete the hardware clock (calendar).</p> <p>To manually update the software with the hardware clock, use the <code>clock read-calendar</code> command.</p>						
<b>Example</b>	<pre>Dell#calendar set 08:55:00 june 18 2006 Dell#</pre>						
<b>Related Commands</b>	<p><a href="#">clock read-calendar</a>— sets the software clock based on the hardware clock.</p> <p><a href="#">clock set</a>— sets the software clock.</p> <p><a href="#">clock update-calendar</a>— sets the hardware clock based on the software clock.</p> <p><a href="#">show clock</a>— displays the clock settings.</p>						

## clock read-calendar

Set the software clock on the switch from the information set in hardware clock (calendar).

<b>Syntax</b>	<code>clock read-calendar</code>
<b>Defaults</b>	Not configured.
<b>Command Modes</b>	EXEC Privilege
<b>Supported Modes</b>	All Modes

<b>Command History</b>	<table border="0"> <thead> <tr> <th style="text-align: left;"><b>Version</b></th> <th style="text-align: left;"><b>Description</b></th> </tr> </thead> <tbody> <tr> <td><b>9.4(0.0)</b></td> <td>Supported on the FN I/O Aggregator.</td> </tr> <tr> <td><b>8.3.17.0</b></td> <td>Supported on the M I/O Aggregator.</td> </tr> </tbody> </table>	<b>Version</b>	<b>Description</b>	<b>9.4(0.0)</b>	Supported on the FN I/O Aggregator.	<b>8.3.17.0</b>	Supported on the M I/O Aggregator.
<b>Version</b>	<b>Description</b>						
<b>9.4(0.0)</b>	Supported on the FN I/O Aggregator.						
<b>8.3.17.0</b>	Supported on the M I/O Aggregator.						

<b>Usage Information</b>	<p>In the switch, the hardware clock is separate from the software and is called the calendar. This hardware clock runs continuously. After the hardware clock (the calendar) is set, the operating system automatically updates the software clock after system bootup.</p> <p>You cannot delete this command (there is not a <code>no</code> version of this command).</p>
--------------------------	--

## clock set

Set the software clock in the switch.

<b>Syntax</b>	<code>clock set time month day year</code>	
<b>Parameters</b>	<b>time</b>	Enter the time in hours:minutes:seconds. For the hour variable, use the 24-hour format; example, 17:15:00 is 5:15 pm.
	<b>month</b>	Enter the name of one of the 12 months, in English. You can enter the number of a day and change the order of the display to <code>time day month year</code> .



**day** Enter the number of the day. The range is from 1 to 31. You can enter the name of a month to change the order of the display to *time month day year* .

**year** Enter a four-digit number as the year. The range is from 1993 to 2035.

**Defaults** Not configured.

**Command Modes** EXEC Privilege

**Supported Modes** All Modes

Command History	Version	Description
	<b>9.4(0.0)</b>	Supported on the FN I/O Aggregator.
	<b>8.3.17.0</b>	Supported on the M I/O Aggregator.

**Usage Information** You can change the order of the `month` and `day` parameters to enter the time and date as *time day month year* . You cannot delete the software clock.

The software clock runs only when the software is up. The clock restarts, based on the hardware clock, when the switch reboots.

Dell Networking recommends using an outside time source, such as NTP, to ensure accurate time on the switch.

**Example**

```
Dell#clock set 12:11:00 21 may 2012
Dell#
```

## clock summer-time date

Set a date (and time zone) on which to convert the switch to daylight saving time on a one-time basis.

**Syntax** `clock summer-time time-zone date start-month start-day start-year start-time end-month end-day end-year end-time [offset]`

To delete a daylight saving time zone configuration, use the `no clock summer-time` command.

Parameters		
<b>time-zone</b>		Enter the three-letter name for the time zone. This name is displayed in the show clock output.
<b>start-month</b>		Enter the name of one of the 12 months in English. You can enter the name of a day to change the order of the display to <i>time day month year</i> .
<b>start-day</b>		Enter the number of the day. The range is from 1 to 31. You can enter the name of a month to change the order of the display to <i>time day month year</i> .
<b>start-year</b>		Enter a four-digit number as the year. The range is from 1993 to 2035.
<b>start-time</b>		Enter the time in hours:minutes. For the hour variable, use the 24-hour format; example, 17:15 is 5:15 pm.
<b>end-day</b>		Enter the number of the day. The range is from 1 to 31. You can enter the name of a month to change the order of the display to <i>time day month year</i> .
<b>end-month</b>		Enter the name of one of the 12 months in English. You can enter the name of a day to change the order of the display to <i>time day month year</i> .
<b>end-time</b>		Enter the time in hours:minutes. For the hour variable, use the 24-hour format; example, 17:15 is 5:15 pm.
<b>end-year</b>		Enter a four-digit number as the year. The range is from 1993 to 2035.
<b>offset</b>	(OPTIONAL)	Enter the number of minutes to add during the summer-time period. The range is from 1 to 1440. The default is <b>60 minutes</b> .

**Defaults** Not configured.

**Command Modes** CONFIGURATION

**Supported Modes** All Modes

**Command History**

**Version**

**8.3.17.0**

**Description**

Supported on the M I/O Aggregator.

**Related Commands**

[clock summer-time recurring](#) — sets a date (and time zone) on which to convert the switch to daylight saving time each year.

[show clock](#) — displays the current clock settings.

## clock summer-time recurring

Set the software clock to convert to daylight saving time on a specific day each year.

**Syntax**

```
clock summer-time time-zone recurring [start-week start-day start-month start-time end-week end-day end-month end-time [offset]]
```

To delete a daylight saving time zone configuration, use the `no clock summer-time` command.

**Parameters**

***time-zone***

Enter the three-letter name for the time zone. This name is displayed in the `show clock` output. You can enter up to eight characters.

***start-week***

(OPTIONAL) Enter one of the following as the week that daylight saving begins and then enter values for start-day through end-time:

- `week-number`: Enter a number from 1 to 4 as the number of the week in the month to start daylight saving time.
- `first`: Enter this keyword to start daylight saving time in the first week of the month.
- `last`: Enter this keyword to start daylight saving time in the last week of the month.

***start-day***

Enter the name of the day that you want daylight saving time to begin. Use English three letter abbreviations; for example, Sun, Sat, Mon, and so on. The range is from Sun to Sat.

***start-month***

Enter the name of one of the 12 months in English.

***start-time***

Enter the time in hours:minutes. For the hour variable, use the 24-hour format; example, 17:15 is 5:15 pm.

***end-week***

Enter the one of the following as the week that daylight saving ends:

- `week-number`: enter a number from 1 to 4 as the number of the week to end daylight saving time.
- `first`: enter the keyword `first` to end daylight saving time in the first week of the month.
- `last`: enter the keyword `last` to end daylight saving time in the last week of the month.

***end-day***

Enter the weekday name that you want daylight saving time to end. Enter the weekdays using the three letter abbreviations; for example Sun, Sat, Mon, and so on. The range is from Sun to Sat.

***end-month***

Enter the name of one of the 12 months in English.

***end-time***

Enter the time in hours:minutes:seconds. For the hour variable, use the 24-hour format; example, 17:15:00 is 5:15 pm.

***offset***

(OPTIONAL) Enter the number of minutes to add during the summer-time period. The range is from 1 to 1440. The default is **60 minutes**.

**Defaults**

Not configured.

**Command Modes** CONFIGURATION

**Supported Modes** All Modes

<b>Command History</b>	<b>Version</b>	<b>Description</b>
	<b>9.4(0.0)</b>	Supported on the FN I/O Aggregator.
	<b>8.3.17.0</b>	Supported on the M I/O Aggregator.

**Related Commands** [clock summer-time date](#) — sets a date (and time zone) on which to convert the switch to daylight saving time on a one-time basis.  
[show clock](#) — displays the current clock settings.

## clock timezone

Configure a timezone for the switch.

**Syntax** `clock timezone timezone-name offset`  
To delete a timezone configuration, use the `no clock timezone` command.

**Parameters**

<b><i>timezone-name</i></b>	Enter the name of the timezone. You cannot use spaces.
<b><i>offset</i></b>	Enter one of the following: <ul style="list-style-type: none"><li>• a number from 1 to 23 as the number of hours in addition to universal time coordinated (UTC) for the timezone.</li><li>• a minus sign (-) then a number from 1 to 23 as the number of hours.</li></ul>

**Defaults** Not configured.

**Command Modes** CONFIGURATION

**Supported Modes** All Modes

<b>Command History</b>	<b>Version</b>	<b>Description</b>
	<b>8.3.17.0</b>	Supported on the M I/O Aggregator.

**Usage Information** Coordinated universal time (UTC) is the time standard based on the International Atomic Time standard, commonly known as Greenwich Mean time. When determining system time, include the differentiator between UTC and your local timezone. For example, San Jose, CA is the Pacific Timezone with a UTC offset of -8.

## clock update-calendar

Set the switch hardware clock based on the software clock.

**Syntax** `clock update-calendar`

**Defaults** Not configured.

**Command Modes** EXEC Privilege

**Supported Modes** All Modes

<b>Command History</b>	<b>Version</b>	<b>Description</b>
	<b>8.3.17.0</b>	Supported on the M I/O Aggregator.

**Usage Information** Use this command only if you are sure that the hardware clock is inaccurate and the software clock is correct. You cannot delete this command (there is not a `no` form of this command).

**Related Commands** [calendar set](#) — sets the hardware clock.

# ntp control-key-passwd

Configure control key password for NTPQ authentication. NTP control key supports encrypted and unencrypted option.

**Syntax** `ntp control-key-passwd [encryption-type] password`  
To delete the control key, use the `no ntp control-key-passwd [encryption-type] password` command.

**Parameters**

**encryption-type** (OPTIONAL) Enter one of the following numbers:

- 0 (zero) directs the system to store the password as clear text. It is the default encryption type when using the password option.
- 7 (seven) indicates that a password is encrypted using a DES hashing algorithm. It specifies a hidden authentication data.
- WORD is the un-encrypted (cleartext) authentication data.

**password** Enter a string up to 32 characters as the password.

**Defaults** NTPQ

**Command Modes** CONFIGURATION

**Command History** This guide is platform-specific. For command information about other platforms, see the relevant *Dell EMC Networking OS Command Line Reference Guide*.

Version	Description
9.14(1.0)	Introduced on the S4810 and S4820T.
9.14(0.0)	Introduced on the C9010, FN-IOM, MIOA, MXL, S3048-ON, S4048-ON, S4048T-ON, S5048F-ON, S6000, S6000-ON, S6010-ON, S6100-ON, and Z9100-ON.

**Usage Information** NTP control key is not configured by default. If the encryption-type (0 or 7) is not specified, then 0 is selected by default.

# ntp server

Configure an NTP time-serving host.

**Syntax** `ntp server {hostname | ipv4-address} [key keyid] [prefer] [version number]`

**Parameters**

**ipv4-address** Enter an IPv4 address (A.B.C.D).

**hostname** Enter the hostname of the server.

**key keyid** (OPTIONAL) Enter the keyword `key` and a number as the NTP peer key. The range is from 1 to 4294967295.

**prefer** (OPTIONAL) Enter the keyword `prefer` to indicate that this peer has priority over other servers.

**version number** (OPTIONAL) Enter the keyword `version` and a number to correspond to the NTP version used on the server. The range is from 1 to 3.

**Defaults** Not configured.

**Command Modes** CONFIGURATION

**Supported Modes** All Modes

**Command History**

Version	Description
9.2(0.0)	Supported on the M I/O Aggregator.

## Usage Information

You can configure multiple time-serving hosts (up to 250). From these time-serving hosts, the operating system chooses one NTP host with which to synchronize.

Because many polls to NTP hosts can impact network performance, Dell Networking recommends limiting the number of hosts configured.

# show calendar

Display the current date and time based on the switch hardware clock.

**Syntax** `show calendar`

- Command Modes**
- EXEC
  - EXEC Privilege

**Supported Modes** All Modes

## Command History

Version	Description
9.4(0.0)	Supported on the FN I/O Aggregator.
8.3.17.0	Supported on the M I/O Aggregator.

## Example

```
Dell#show calendar
12:29:34 pacific Tue May 22 2012
Dell#
```

## Related Commands

[show clock](#)— displays the time and date from the switch software clock.

# show clock

Displays the current clock settings.

**Syntax** `show clock [detail]`

**Parameters**

**detail** (OPTIONAL) Enter the keyword `detail` to view the source information of the clock.

- Command Modes**
- EXEC
  - EXEC Privilege

**Supported Modes** All Modes

## Command History

Version	Description
9.4(0.0)	Supported on the FN I/O Aggregator.
8.3.17.0	Supported on the M I/O Aggregator.

## Example

```
Dell#show clock
12:30:04.402 pacific Tue May 22 2012
Dell#
```

## Example (Detail)

```
Dell#show clock detail
12:30:26.892 pacific Tue May 22 2012
Time source is RTC hardware
Summer time starts 00:00:00 UTC Wed Mar 14 2012
Summer time ends 00:00:00 pacific Wed Nov 7 2012
Dell#
```

**Related  
Commands**

[clock summer-time recurring](#) — sets the software clock to convert to daylight saving time on a specific day each year.

[ntp server](#) — configures an NTP time-serving host.

# Uplink Failure Detection (UFD)

Uplink failure detection (UFD) provides detection of the loss of upstream connectivity and, if you use this with network interface controller (NIC) teaming, automatic recovery from a failed link.

**NOTE:** In Standalone, VLT, and Stacking modes, the UFD group number is 1 by default and cannot be changed.

## Topics:

- [clear ufd-disable](#)
- [debug uplink-state-group](#)
- [defer-timer](#)
- [description](#)
- [downstream](#)
- [downstream auto-recover](#)
- [downstream disable links](#)
- [enable](#)
- [show running-config uplink-state-group](#)
- [show uplink-state-group](#)
- [uplink-state-group](#)
- [upstream](#)

## clear ufd-disable

Re-enable one or more downstream interfaces on the switch/router that are in a UFD-Disabled Error state so that an interface can send and receive traffic.

**Syntax** `clear ufd-disable {interface interface | uplink-state-group group-id}`

### Parameters

<b>interface</b> <i>interface</i>	Specify one or more downstream interfaces. For <i>interface</i> , enter one of the following interface types: <ul style="list-style-type: none"> <li>• 10 Gigabit Ethernet: <code>tengigabitethernet {slot/port   slot/ port-range}</code></li> <li>• Port channel: <code>port-channel {1-512   port-channel-range}</code></li> </ul> Where <i>port-range</i> and <i>port-channel-range</i> specify a range of ports separated by a dash (-) and/or individual ports/port channels in any order; for example: <code>tengigabitethernet 1/1-2,5,9,11-12 port-channel 1-3,5</code> . A comma is required to separate each port and port-range entry.
<b>uplink-state-group</b> <i>group-id</i>	Re-enables all UFD-disabled downstream interfaces in the group. The valid <i>group-id</i> values are from 1 to 16.

**Defaults** A downstream interface in a UFD-disabled uplink-state group is also disabled and is in a UFD-Disabled Error state.

**Command Modes** CONFIGURATION

**Supported Modes** Programmable-Mux (PMUX)

### Command History

Version	Description
9.4(0.0)	Supported on the FN I/O Aggregator.
9.2(0.0)	Supported on the M I/O Aggregator.

- Related Commands**
- [downstream](#) — assigns a port or port-channel to the uplink-state group as a downstream interface.
  - [uplink-state-group](#) — creates an uplink-state group and enables the tracking of upstream links.

## debug uplink-state-group

Enable debug messages for events related to a specified uplink-state group or all groups.

**Syntax** `debug uplink-state-group [group-id]`

To turn off debugging event messages, enter the `no debug uplink-state-group [group-id]` command.

**Parameters**

**group-id** Enables debugging on the specified uplink-state group. The valid group-id values are from 1 to 16.

**Defaults** none

**Command Modes** EXEC Privilege

**Supported Modes** Programmable-Mux (PMUX)

Command History	Version	Description
	<b>9.4(0.0)</b>	Supported on the FN I/O Aggregator.
	<b>9.2(0.0)</b>	Supported on the M I/O Aggregator.

**Related Commands** [clear ufd-disable](#) — re-enables downstream interfaces that are in a UFD-Disabled Error state.

## defer-timer

Configure a timer that prevents unwanted flapping of downstream ports when the uplink port channel goes down and comes up.

**Syntax** `defer-timerseconds`

**Defaults** 10 (Standalone mode)

**Parameters**

**seconds** Specify the time (in seconds) to wait for the upstream port channel (LAG 128) to come back up before server ports are brought down. The range is from 1 to 120.

**Command Modes** UPLINK-STATE-GROUP

**Supported Modes** Standalone, Stacking, VLT

Command History	Version	Description
	<b>9.4(0.0)</b>	Supported on the FN I/O Aggregator.
	<b>9.2(0.0)</b>	Supported on the M I/O Aggregator.

**Usage Information** This command is not supported in Programmable-Mux mode.

## description

Enter a text description of an uplink-state group.

**Syntax** `description text`



**Parameters** *text* Text description of the uplink-state group. The maximum length is 80 alphanumeric characters.

**Defaults** none

**Command Modes** UPLINK-STATE-GROUP

**Supported Modes** Programmable-Mux (PMUX)

<b>Command History</b>	<b>Version</b>	<b>Description</b>
	<b>9.4(0.0)</b>	Supported on the FN I/O Aggregator.
	<b>9.2(0.0)</b>	Supported on the M I/O Aggregator.

#### Example

```
Dell(conf-uplink-state-group-16)# description test
Dell(conf-uplink-state-group-16)#
```

**Related Commands** [uplink-state-group](#) — creates an uplink-state group and enables the tracking of upstream links.

## downstream

Assign a port or port-channel to the uplink-state group as a downstream interface.

**Syntax** `downstream interface`

To delete an uplink-state group, enter the `no downstream interface` command.

**Parameters** *interface*

Enter one of the following interface types:

- Fast Ethernet: `fastethernet {slot/port | slot/port-range}`
- 1 Gigabit Ethernet: `gigabitethernet {slot/port | slot/port-range}`
- 10 Gigabit Ethernet: `tengigabitethernet {slot/port | slot/port-range}`
- Port channel: `port-channel {1-512 | port-channel-range}`

Where `port-range` and `port-channel-range` specify a range of ports separated by a dash (-) and/or individual ports/port channels in any order; for example: `gigabitethernet 1/1-2,5,9,11-12 port-channel 1-3,5`. A comma is required to separate each port and port-range entry.

**Defaults** none

**Command Modes** UPLINK-STATE-GROUP

**Supported Modes** Programmable-Mux (PMUX)

**Command History** This guide is platform-specific. For command information about other platforms, refer to the relevant *Dell Networking OS Command Line Reference Guide*.

The following is a list of the Dell Networking OS version history for this command.

<b>Version</b>	<b>Description</b>
<b>9.2(0.0)</b>	Introduced on the M I/O Aggregator.

#### Usage Information

You can assign physical port or port-channel interfaces to an uplink-state group.

You can assign an interface to only one uplink-state group. Configure each interface assigned to an uplink-state group as either an upstream or downstream interface, but not both.

You can assign individual member ports of a port channel to the group. An uplink-state group can contain either the member ports of a port channel or the port channel itself, but not both.

**Related  
Commands**

- [upstream](#) — assigns a port or port-channel to the uplink-state group as an upstream interface.

## downstream auto-recover

Enable auto-recovery so that UFD-disabled downstream ports in an uplink-state group automatically come up when a disabled upstream port in the group comes back up.

**Syntax** `downstream auto-recover`  
To disable auto-recovery on downstream links, use the `no downstream auto-recover` command.

**Defaults** The auto-recovery of UFD-disabled downstream ports is enabled.

**Command Modes** UPLINK-STATE-GROUP

**Supported Modes** Programmable-Mux (PMUX)

Command History	Version	Description
	<b>9.4(0.0)</b>	Supported on the FN I/O Aggregator.
	<b>9.2(0.0)</b>	Supported on the M I/O Aggregator.

**Related  
Commands**

- [downstream](#) — assigns a port or port-channel to the uplink-state group as a downstream interface.
- [uplink-state-group](#) — creates an uplink-state group and enables the tracking of upstream links.

## downstream disable links

Configure the number of downstream links in the uplink-state group that are disabled if one upstream link in an uplink-state group goes down.

**Syntax** `downstream disable links {number | all}`  
To revert to the default setting, use the `no downstream disable links` command.

**Parameters**

<b><i>number</i></b>	Enter the number of downstream links to be brought down by UFD. The range is from 1 to 1024.
<b>all</b>	Brings down all downstream links in the group.

**Defaults** No downstream links are disabled when an upstream link in an uplink-state group goes down.

**Command Modes** UPLINK-STATE-GROUP

**Supported Modes** Programmable-Mux (PMUX)

Command History	Version	Description
	<b>9.4(0.0)</b>	Supported on the FN I/O Aggregator.
	<b>9.2(0.0)</b>	Supported on the M I/O Aggregator.

**Usage  
Information**

A user-configurable number of downstream interfaces in an uplink-state group are put into a link-down state with an UFD-Disabled error message when one upstream interface in an uplink-state group goes down.

If all upstream interfaces in an uplink-state group go down, all downstream interfaces in the same uplink-state group are put into a link-down state.

**Related  
Commands**

- [downstream](#) — assigns a port or port-channel to the uplink-state group as a downstream interface.
- [uplink-state-group](#) — creates an uplink-state group and enables the tracking of upstream links.

# enable

Re-enable upstream-link tracking for an uplink-state group after it has been disabled.

- Syntax** `enable`
- To disable upstream-link tracking without deleting the uplink-state group, use the `no enable` command.
- group-id** Enables debugging on the specified uplink-state group. Valid *group-id* values are 1 to 16.
- Defaults** Upstream-link tracking is automatically enabled in an uplink-state group.
- Command Modes** UPLINK-STATE-GROUP
- Supported Modes** All Modes

Command History	Version	Description
	<b>9.4(0.0)</b>	Supported on the FN I/O Aggregator.
	<b>9.2(0.0)</b>	Supported on the M I/O Aggregator.

# show running-config uplink-state-group

Display the current configuration of one or more uplink-state groups.

- Syntax** `show running-config uplink-state-group [group-id]`
- Parameters** *group-id* Displays the current configuration of all uplink-state groups or a specified group. The valid group-id values are from 1 to 16.
- Defaults** none
- Command Modes**
- EXEC
  - EXEC Privilege
- Supported Modes** Programmable-Mux (PMUX)

Command History	Version	Description
	<b>9.4(0.0)</b>	Supported on the FN I/O Aggregator.
	<b>9.2(0.0)</b>	Supported on the M I/O Aggregator.

## Example

```
Dell#show running-config uplink-state-group
!
no enable
uplink state track 1
downstream TengigabitEthernet 0/2,4,6,11
upstream TengigabitEthernet 0/8, 12
upstream PortChannel 1
!
uplink state track 2
downstream TengigabitEthernet 0/1,3,5
upstream TengigabitEthernet 0/9,10
```

- Related Commands**
- [show uplink-state-group](#) — displays the status information on a specified uplink-state group or all groups.
  - [uplink-state-group](#) — creates an uplink-state group and enables the tracking of upstream links.

# show uplink-state-group

Display status information on a specified uplink-state group or all groups.

<b>Syntax</b>	show uplink-state-group [ <i>group-id</i> ] [ <i>detail</i> ]	
<b>Parameters</b>	<b>group-id</b>	Displays status information on a specified uplink-state group or all groups. The valid group-id values are from 1 to 16.
	<b>detail</b>	Displays additional status information on the upstream and downstream interfaces in each group
<b>Defaults</b>	none	
<b>Command Modes</b>	<ul style="list-style-type: none"><li>EXEC</li><li>EXEC Privilege</li></ul>	
<b>Supported Modes</b>	Programmable-Mux (PMUX)	
<b>Command History</b>	This guide is platform-specific. For command information about other platforms, refer to the relevant <i>Dell Networking OS Command Line Reference Guide</i> .	

The following is a list of the Dell Networking OS version history for this command.

Version	Description
9.2(0.0)	Introduced on the M I/O Aggregator.

## Example

```
Dell# show uplink-state-group
Uplink State Group: 1 Status: Enabled, Up
Uplink State Group: 3 Status: Enabled, Up
Uplink State Group: 5 Status: Enabled, Down
Uplink State Group: 6 Status: Enabled, Up
Uplink State Group: 7 Status: Enabled, Up
Uplink State Group: 16 Status: Disabled, Up

Dell# show uplink-state-group 16
Uplink State Group: 16 Status: Disabled, Up

Dell#show uplink-state-group detail
(Up): Interface up (Dwn): Interface down (Dis): Interface disabled
Uplink State Group : 1 Status: Enabled, Up
Upstream Interfaces :
Downstream Interfaces :

Uplink State Group : 3 Status: Enabled, Up
Upstream Interfaces : Gi 0/46(Up) Gi 0/47(Up)
Downstream Interfaces : Te 13/0(Up) Te 13/1(Up) Te 13/3(Up) Te 13/5(Up)
Te 13/6(Up)

Uplink State Group : 5 Status: Enabled, Down
Upstream Interfaces : Gi 0/0(Dwn) Gi 0/3(Dwn) Gi 0/5(Dwn)
Downstream Interfaces : Te 13/2(Dis) Te 13/4(Dis) Te 13/11(Dis) Te
13/12(Dis) Te 13/13(Dis) Te 13/14(Dis) Te 13/15(Dis)

Uplink State Group : 6 Status: Enabled, Up
Upstream Interfaces :
Downstream Interfaces :

Uplink State Group : 7 Status: Enabled, Up
Upstream Interfaces :
Downstream Interfaces :

Uplink State Group : 16 Status: Disabled, Up
Upstream Interfaces : Gi 0/41(Dwn) Po 8(Dwn)
Downstream Interfaces : Gi 0/40(Dwn)
```

# uplink-state-group

Create an uplink-state group and enable the tracking of upstream links on a switch/ router.

**Syntax** `uplink-state-group group-id`  
To delete an uplink-state group, enter the `no uplink-state-group group-id` command.

**Parameters** *group-id* Enter the ID number of an uplink-state group. The range is from 1 to 16.

**Defaults** none

**Command Modes** CONFIGURATION

**Supported Modes** Programmable-Mux (PMUX)

Command History	Version	Description
	9.4(0.0)	Supported on the FN I/O Aggregator.
	9.2(0.0)	Supported on the M I/O Aggregator.

**Usage Information** After you enter the command, to assign upstream and downstream interfaces to the group, enter Uplink-State-Group Configuration mode.

An uplink-state group is considered to be operationally up if at least one upstream interface in the group is in the Link-Up state.

An uplink-state group is considered to be operationally down if no upstream interfaces in the group are in the Link-Up state. No uplink-state tracking is performed when a group is disabled or in an operationally down state.

To disable upstream-link tracking without deleting the uplink-state group, use the `no enable` command in uplink-state-group configuration mode.

## Example

```
Dell(conf)#uplink-state-group 16
Dell(conf)#
02:23:17: %RPM0-P:CP %IFMGR-5-ASTATE_UP: Changed uplink state group
Admin state to up: Group 16
```

- Related Commands**
- [show running-config uplink-state-group](#) — displays the current configuration of one or more uplink-state groups.
  - [show uplink-state-group](#) — displays the status information on a specified uplink-state group or all groups.

# upstream

Assign a port or port-channel to the uplink-state group as an upstream interface.

**Syntax** `upstream interface`  
To delete an uplink-state group, use the `no upstream interface` command.

- Parameters** *interface* Enter one of the following interface types:
- Fast Ethernet: `fastethernet {slot/port | slot/port-range}`
  - 1 Gigabit Ethernet: `gigabitethernet {slot/port | slot/port-range}`
  - 10 Gigabit Ethernet: `tengigabitethernet {slot/port | slot/port-range}`
  - 40 Gigabit Ethernet: `fortyGigE {slot/port | slot/port-range}`
  - Port channel: `port-channel {1-512 | port-channel-range}`

Where `port-range` and `port-channel-range` specify a range of ports separated by a dash (-) and/or individual ports/port channels in any order; for example: `gigabitethernet 1/1-2,5,9,11-12 port-channel 1-3,5`. A comma is required to separate each port and port-range entry.

**Defaults** none

**Command Modes** UPLINK-STATE-GROUP

**Supported Modes** Programmable-Mux (PMUX)

**Command History** This guide is platform-specific. For command information about other platforms, refer to the relevant *Dell Networking OS Command Line Reference Guide*.

The following is a list of the Dell Networking OS version history for this command.

Version	Description
9.2(0.0)	Introduced on the M I/O Aggregator.

**Usage Information**

You can assign physical port or port-channel interfaces to an uplink-state group.

You can assign an interface to only one uplink-state group. Configure each interface assigned to an uplink-state group as either an upstream or downstream interface, but not both.

You can assign individual member ports of a port channel to the group. An uplink-state group can contain either the member ports of a port channel or the port channel itself, but not both.

**Example**

```
Dell(conf-uplink-state-group-16)# upstream gigabitethernet 1/10-15
Dell(conf-uplink-state-group-16)#
```

**Related Commands**

- [downstream](#) — assigns a port or port-channel to the uplink-state group as a downstream interface.

## Virtual Link Trunking (VLT)

VLT allows physical links between two chassis to appear as a single virtual link to the network core. VLT eliminates the requirement for Spanning Tree protocols by allowing link aggregation group (LAG) terminations on two separate distribution or core switches, and by supporting a loop-free topology. VLT provides Layer 2 multipathing, creating redundancy through increased bandwidth and enabling multiple parallel paths between nodes and load-balancing traffic where alternative paths exist.

**NOTE:** When you launch the VLT link, the VLT peer-ship is not established if any of the following is **TRUE**:

- The VLT System-MAC configured on both the VLT peers do not match.
- The VLT Unit-Id configured on both the VLT peers are identical.
- The VLT System-MAC or Unit-Id is configured only on one of the VLT peers.
- The VLT domain ID is not the same on both peers.

If the VLT peer-ship is already established, changing the System-MAC or Unit-Id does not cause VLT peer-ship to go down.

Also, if the VLT peer-ship is already established and the VLT Unit-Id or System-MAC are configured on both peers, then changing the CLI configurations on the VLT Unit-Id or System-MAC is rejected if any of the following become **TRUE**:

- After making the CLI configuration change, the VLT Unit-Id becomes identical on both peers.
- After making the CLI configuration change, the VLT System-MAC do not match on both peers.

When the VLT peer-ship is already established, you can remove the VLT Unit-Id or System-MAC configuration from either or both peers. However, removing configuration settings can cause the VLT ports to go down if you configure the Unit-Id or System-MAC on only one of the VLT peers.

### Topics:

- [back-up destination](#)
- [clear vlt statistics](#)
- [lACP ungroup member-independent](#)
- [peer-link port-channel](#)
- [show vlt backup-link](#)
- [show vlt brief](#)
- [show vlt detail](#)
- [show vlt mismatch](#)
- [show vlt role](#)
- [show vlt statistics](#)
- [stack-unit iom-mode](#)
- [system-mac](#)
- [unit-id](#)
- [vlt domain](#)
- [vlt-peer-lag port-channel](#)

## back-up destination

Configure the IPv4 or IPv6 address of the management interface on the remote VLT peer to be used as the endpoint of the VLT backup link for sending out-of-band hello messages.

**Syntax** `back-up destination {[ipv4-address] | [ipv6 ipv6-address] [interval seconds]}`

**Parameters**

<b>ipv4-address</b>	Enter the IPv4 address of the backup destination.
<b>ipv6</b>	Enter the keyword <code>ipv6</code> then an IPv6 address in the X:X:X::X format.

**interval *seconds*** Enter the keyword `interval` to specify the time interval to send hello messages. The range is from 1 to 5 seconds. The default is 1 second.

**Defaults** 1 second

**Command Modes** VLT DOMAIN

**Supported Modes** Programmable-Mux (PMUX)

Command History	Version	Description
	9.4(0.0)	Supported on the FN I/O Aggregator.
	9.2(0.0)	Supported on the M I/O Aggregator.

## clear vlt statistics

Clear the statistics on VLT operations.

**Syntax** `clear vlt statistics [arp | domain | igmp-snoop | mac | multicast | ndp]`

Parameters	Parameter	Description
	<b>domain</b>	Clear the VLT statistics for the domain.
	<b>multicast</b>	Clear the VLT statistics for multicast.
	<b>mac</b>	Clear the VLT statistics for the MAC address.
	<b>arp</b>	Clear the VLT statistics for ARP.
	<b>igmp-snoop</b>	Clear the VLT statistics for IGMP snooping.
	<b>ndp</b>	Clear the VLT statistics for NDP.

**Command Modes** EXEC

**Supported Modes** Programmable-Mux (PMUX)  
Full-Switch

Command History	Version	Description
	9.4(0.0)	Supported on the FN I/O Aggregator.
	9.2(0.0)	Supported on the M I/O Aggregator.

### Example

```
VLT ARP Statistics
-----
ARP Tunnel Pkts sent:0
ARP Tunnel Pkts Rcvd:0
ARP-sync Pkts Sent:0
ARP-sync Pkts Rcvd:0
ARP Reg Request sent:19
ARP Reg Request rcvd:10
```

## lACP ungroup member-independent

Prevent possible loop during the bootup of a VLT peer switch or a device that accesses the VLT domain.

**Syntax** `lACP ungroup member-independent {vlt | port-channel}`

Parameters	Parameter	Description
	<b>port-channel</b>	Force all LACP port-channel members to become switchports.
	<b>vlt</b>	Force all VLT LACP members to become switchports.



<b>Defaults</b>	Not configured.	
<b>Command Modes</b>	CONFIGURATION	
<b>Supported Modes</b>	Programmable-Mux (PMUX)	
<b>Command History</b>	<b>Version</b>	<b>Description</b>
	<b>9.4(0.0)</b>	Supported on the FN I/O Aggregator.
	<b>9.2(0.0)</b>	Supported on the M I/O Aggregator.
<b>Usage Information</b>	LACP on the VLT ports (on a VLT switch or access device), which are members of the virtual link trunk, is not brought up until the VLT domain is recognized on the access device.	
	To ungroup the VLT and port-channel configurations, use the <b>no lacp ungroup member independent</b> command on a VLT port channel, depending on whether the port channel is VLT or non-VLT.	

#### Example

```
Dell(conf)#lacp ungroup member-independent ?
port-channel          LACP port-channel members become switchports
vlt                   All VLT LACP members become
switchports
```

## peer-link port-channel

Configure the specified port channel as the chassis interconnect trunk between VLT peers in the domain.

<b>Syntax</b>	<code>peer-link port-channel <i>port-channel-number</i> {peer-down-vlan <i>vlan id</i>}</code>	
<b>Parameters</b>	<b><i>port-channel-number</i></b>	Enter the port-channel number that acts as the interconnect trunk.
	<b>peer-down-vlan <i>vlan id</i></b>	Enter the keyword <code>peer-down-vlan</code> then a VLAN ID to configure the VLAN that the VLT peer link uses when the VLT peer is down.
<b>Defaults</b>	Not configured.	
<b>Command Modes</b>	VLT DOMAIN	
<b>Supported Modes</b>	Programmable-Mux (PMUX)	
<b>Command History</b>	<b>Version</b>	<b>Description</b>
	<b>9.4(0.0)</b>	Supported on the FN I/O Aggregator.
	<b>9.2(0.0)</b>	Supported on the M I/O Aggregator.
<b>Usage Information</b>	To configure the VLAN from where the VLT peer forwards packets received over the VLTi from an adjacent VLT peer that is down, use the <b>peer-down-vlan</b> parameter. To ensure that the DHCP discover packets are forwarded to the VLAN that has the DHCP server, use this configuration.	

## show vlt backup-link

Displays information on the backup link operation.

<b>Syntax</b>	<code>show vlt backup-link</code>
<b>Default</b>	Not configured.
<b>Command Modes</b>	EXEC
<b>Supported Modes</b>	All Modes

Command History	Version	Description
	9.4(0.0)	Supported on the FN I/O Aggregator.
	9.2(0.0)	Supported on the M I/O Aggregator.

#### Example

```
Dell# show vlt backup-link
VLT Backup Link
-----
Destination:                169.254.31.23
Peer HeartBeat status:      Up
HeartBeat Timer Interval:   1
HeartBeat Timeout:         3
UDP Port:                   34998
HeartBeat Messages Sent:    24
HeartBeat Messages Received: 25
```

## show vlt brief

Display brief status information about VLT domains currently configured on the switch.

<b>Syntax</b>	show vlt brief
<b>Default</b>	Not configured.
<b>Command Modes</b>	EXEC
<b>Supported Modes</b>	All Modes

Command History	Version	Description
	9.4(0.0)	Supported on the FN I/O Aggregator.
	9.2(0.0)	Supported on the M I/O Aggregator.

#### Example (Brief)

```
Dell#show vlt br
VLT Domain Brief
-----
Domain ID                : 1
Role                     : Secondary
Role Priority            : 32768
ICL Link Status          : Up
HeartBeat Status        : Up
VLT Peer Status         : Up
Version                  : 6(3)
Local System MAC address : 00:01:e8:8a:e9:91
Remote System MAC address : 00:01:e8:8a:e9:76
Remote system version    : 6(3)
Delay-Restore timer      : 90 seconds

Delay-Restore Abort Threshold : 60 seconds
Peer-Routing                : Disabled
Peer-Routing-Timeout timer  : 0 seconds
Multicast peer-routing timeout : 150 seconds
Dell#
```

## show vlt detail

Displays detailed status information about VLT domains currently configured on the switch.

<b>Syntax</b>	show vlt detail
<b>Default</b>	Not configured.

**Command Modes** EXEC

**Supported Modes** All Modes

**Command History**

**Version**

**Description**

**9.4(0.0)**

Supported on the FN I/O Aggregator.

**9.2(0.0)**

Supported on the M I/O Aggregator.

**Example**

```
Dell# show vlt detail
Local LAG Id Peer LAG Id Local Status Peer Status Active VLANs
-----
128          128          UP          UP          1000
Dell#
```

## show vlt mismatch

Display mismatches in VLT parameters.

**Syntax** show vlt mismatch

**Command Modes** EXEC

**Supported Modes** Programmable-Mux (PMUX)

**Command History**

**Version**

**Description**

**9.4(0.0)**

Supported on the FN I/O Aggregator.

**9.2(0.0)**

Supported on the M I/O Aggregator.

**Example**

```
Dell#show vlt mismatch
Domain
-----
Parameters Local Peer
-----
Unit-ID 0 15

Vlan-config
-----
Vlan-ID Local Mode Peer Mode
-----
100 -- L3

Vlan IPV4 Multicast Status
-----
Vlan-ID Local Status Peer Status
-----
4094 Active Inactive
Dell#
```

## show vlt role

Display the VLT peer status, role of the local VLT switch, VLT system MAC address and system priority, and the MAC address and priority of the locally-attached VLT device.

**Syntax** show vlt role

**Default** Not configured.

**Command Modes** EXEC

**Supported Modes** All Modes

**Command History**

Version	Description
9.4(0.0)	Supported on the FN I/O Aggregator.
9.2(0.0)	Supported on the M I/O Aggregator.

**Example**

```
Dell#show vlt role
VLT Role
-----
VLT Role: Primary
System MAC address: 00:01:05:08:02:05
Primary Role Priority: 32768
Local System MAC address: 00:01:e8:00:ab:03
Local System Role Priority: 32768
Local Unit Id: 0
Dell#
```

## show vlt statistics

Displays statistics on VLT operations.

**Syntax** show vlt statistics

**Default** Not configured.

**Command Modes** EXEC

**Supported Modes** All Modes

**Command History**

Version	Description
9.4(0.0)	Supported on the FN I/O Aggregator.
9.2(0.0)	Supported on the M I/O Aggregator.

**Example**

```
Dell#show vlt statistics
VLT Domain Statistics
-----
HeartBeat Messages Sent: 449
HeartBeat Messages Received: 448
ICL Hello's Sent: 154
ICL Hello's Received: 154
Domain Mismatch Errors: 0
Version Mismatch Errors: 0
Config Mismatch Errors: 0

VLT MAC Statistics
-----
L2 Info Pkts sent:16, L2 Mac-sync Pkts Sent:25
L2 Info Pkts Rcvd:15, L2 Mac-sync Pkts Rcvd:24
L2 Reg Request sent:2
L2 Reg Request rcvd:1
L2 Reg Response sent:1
L2 Reg Response rcvd:1

VLT Igmp-Snooping Statistics
-----
IGMP Info Pkts sent: 9
IGMP Info Pkts Rcvd: 10
IGMP Reg Request sent: 2
IGMP Reg Request rcvd: 2
IGMP Reg Response sent: 2
IGMP Reg Response rcvd: 1
```

```

IGMP PDU Tunnel Pkt sent: 0
IGMP PDU Tunnel Pkt rcvd: 0
IGMP Tunnel PDUs sent: 0
IGMP Tunnel PDUs rcvd: 0

VLT ARP Statistics
-----
ARP Tunnel Pkts sent:0
ARP Tunnel Pkts Rcvd:0
ARP Tunnel Pkts sent Non Vlt:0
ARP Tunnel Pkts Rcvd Non Vlt:0
ARP-sync Pkts Sent:0
ARP-sync Pkts Rcvd:0
ARP Reg Request sent:2
ARP Reg Request rcvd:1
VLT IOA Statistics
-----
IOA Info Pkts sent: 5
IOA Info Pkts Rcvd: 7
IOA Reg Request sent: 2
IOA Reg Request rcvd: 2
IOA Reg Response sent: 2
IOA Reg Response rcvd: 1
VLT NDP Statistics
-----
NDP NA VLT Tunnel Pkts sent:0
NDP NA VLT Tunnel Pkts Rcvd:0
NDP NA Non-VLT Tunnel Pkts sent:0
NDP NA Non-VLT Tunnel Pkts Rcvd:0
Ndp-sync Pkts Sent:0
Ndp-sync Pkts Rcvd:0
Ndp Reg Request sent:2
Ndp Reg Request rcvd:1
VLT multicast not enabled

```

## stack-unit iom-mode

Set the switch operating mode to VLT mode.

**Syntax** `stack-unit <unit-number> iom-mode vlt`

**Parameters**

<b>unit number</b> <b>&lt;0-5&gt;</b>	Enter the number of the member stack unit. The range is from 0 to 5. The default is 0.
<b>vlt</b>	Enable virtual link trunking mode.

**Command Modes** CONFIGURATION

**Supported Modes** All Modes

Command History	Version	Description
	<b>9.4(0.0)</b>	Supported on the FN I/O Aggregator.
	<b>9.2(0.0)</b>	Supported on the M I/O Aggregator.

**Usage Information** This command resets the operating mode to VLT. You must reboot the switch after using this command.

## system-mac

Reconfigure the default MAC address for the domain.

**Syntax** `system-mac mac-address`

<b>Parameters</b>	<b>mac-address</b>	Enter the system MAC address for the VLT domain.
<b>Defaults</b>	Not configured.	
<b>Command Modes</b>	VLT DOMAIN	
<b>Supported Modes</b>	Programmable-Mux (PMUX)	
<b>Command History</b>	<b>Version</b>	<b>Description</b>
	<b>9.4(0.0)</b>	Supported on the FN I/O Aggregator.
	<b>9.2(0.0)</b>	Supported on the M I/O Aggregator.
<b>Usage Information</b>	<p>When you create a VLT domain on a switch, Dell Networking OS automatically creates a VLT-system MAC address used for internal system operations.</p> <p>To reconfigure the default MAC address for the domain by entering a new MAC address in the format nn:nn:nn:nn:nn:nn, use the <code>system-mac</code> command.</p> <p>You must also reconfigure the same MAC address on the VLT peer switch.</p>	

## unit-id

Explicitly configure the default unit ID of a VLT peer switch.

<b>Syntax</b>	<code>unit-id [0   1]</code>	
<b>Parameters</b>	<b>0   1</b>	Configure the default unit ID of a VLT peer switch. Enter 0 for the first peer or enter 1 for the second peer.
<b>Defaults</b>	Automatically assigned based on the MAC address of each VLT peer. The peer with the lower MAC address is assigned unit 0; the peer with the higher MAC address is assigned unit 1.	
<b>Command Modes</b>	VLT DOMAIN	
<b>Supported Modes</b>	Programmable-Mux (PMUX)	
<b>Command History</b>	<b>Version</b>	<b>Description</b>
	<b>9.4(0.0)</b>	Supported on the FN I/O Aggregator.
	<b>9.2(0.0)</b>	Supported on the M I/O Aggregator.
<b>Usage Information</b>	<p>When you create a VLT domain on a switch, Dell Networking OS automatically assigns a unique unit ID (0 or 1) to each peer switch. The unit IDs are used for internal system operations. Use the <code>unit-id</code> command to explicitly configure the unit ID of a VLT peer. Configure a different unit ID (0 or 1) on each peer switch.</p> <p>To minimize the time required for the VLT system to determine the unit ID assigned to each peer switch when one peer reboots, use this command.</p>	

## vlt domain

Enable VLT on a switch, configure a VLT domain, and enter VLT-domain configuration mode.

<b>Syntax</b>	<code>vlt domain domain-id</code>	
<b>Parameters</b>	<b>domain-id</b>	Enter the Domain ID number. Configure the same domain ID on the peer switch. The range of domain IDs is from 1 to 1000.
<b>Command Modes</b>	CONFIGURATION	
<b>Supported Modes</b>	Programmable-Mux (PMUX)	

<b>Command History</b>	<b>Version</b>	<b>Description</b>
	<b>9.4(0.0)</b>	Supported on the FN I/O Aggregator.
	<b>9.2(0.0)</b>	Supported on the M I/O Aggregator.
<b>Usage Information</b>	The VLT domain ID must be the same between the two VLT devices. If the domain ID is not the same, a syslog message is generated and VLT does not launch.	

## vlt-peer-lag port-channel

Associate the port channel to the corresponding port channel in the VLT peer for the VLT connection to an attached device.

<b>Syntax</b>	<code>vlt-peer-lag port-channel <i>id-number</i></code>	
<b>Parameters</b>	<b><i>id-number</i></b>	Enter the respective vlt port-channel number of the peer device.
<b>Defaults</b>	Not configured.	
<b>Command Modes</b>	INTERFACE PORT-CHANNEL	
<b>Supported Modes</b>	Programmable-Mux (PMUX)	

<b>Command History</b>	<b>Version</b>	<b>Description</b>
	<b>9.4(0.0)</b>	Supported on the FN I/O Aggregator.
	<b>9.2(0.0)</b>	Supported on the M I/O Aggregator.

# Debugging and Diagnostics

This chapter contains the following sections:

- [Offline Diagnostic Commands](#)
- [Hardware Commands](#)

## Topics:

- [Offline Diagnostic Commands](#)
- [Hardware Commands](#)
- [clear hardware stack-unit](#)
- [diag stack-unit](#)
- [hardware watchdog](#)
- [offline stack-unit](#)
- [show diag](#)
- [show hardware stack-unit](#)
- [show hardware counters interface](#)
- [show hardware buffer interface](#)
- [show hardware system-flow](#)
- [show hardware buffer-stats-snapshot](#)
- [show hardware stack-unit buffer-stats-snapshot \(Total Buffer Information\)](#)
- [show hardware drops](#)

## Offline Diagnostic Commands

The offline diagnostics test suite is useful for isolating faults and debugging hardware. While tests are running, the Dell Networking OS results are saved as a text file (TestReport-SU-X.txt) in the flash directory. The `show file` command is available only on Master and Standby.

### Important Points to Remember

- Offline diagnostics can only be run when the unit is offline.
- Offline diagnostics cannot be run in Stacking mode.
- You can only run offline diagnostics on a unit to which you are connected via the console. In other words, you cannot run diagnostics on a unit to which you are connected via a stacking link.
- Diagnostic results are stored in a file (TestReport-SU-X.txt) in the flash directory. To review the results, use the `show file` command, which prints the results to the screen.
- Diagnostics only test connectivity, not the entire data path.

The offline diagnostics commands are:

- [diag stack-unit](#)
- [offline stack-unit](#)
- [show diag](#)

## Hardware Commands

These commands display information from a hardware sub-component or ASIC.

The hardware commands are:

- [clear hardware stack-unit](#)
- [show diag](#)
- [show hardware stack-unit](#)
- [show hardware system-flow](#)



# clear hardware stack-unit

Clear statistics from selected hardware components.

**Syntax** `clear hardware stack-unit 0-5 {counters | unit 0-1 counters | cpu data-plane statistics | cpu party-bus statistics | stack-port 0-52}`

<b>Parameters</b>	<b>stack-unit 0-5</b>	Enter the keywords <code>stack-unit</code> then 0 to 5 to select a particular stack member and then enter one of the following command options to clear a specific collection of data.
	<b>counters</b>	Enter the keyword <code>counters</code> to clear the counters on the selected stack member.
	<b>unit 0-0 counters</b>	Enter the keyword <code>unit</code> along with a port-pipe number, from 0 to 1, then the keyword <code>counters</code> to clear the counters on the selected port-pipe.
	<b>cpu data-plane statistics</b>	Enter the keywords <code>cpu data-plane statistics</code> to clear the data plane statistics.
	<b>cpu party-bus statistics</b>	Enter the keywords <code>cpu party-bus statistics</code> to clear the management statistics.
	<b>stack-port 33-56</b>	Enter the keywords <code>stack-port</code> then the port number of the stacking port to clear the statistics of the particular stacking port. The range is from 33 to 56.  <b>NOTE:</b> You can identify stack port numbers by physical inspection of the rear modules. The numbering is the same as for the 10G ports. You can also inspect the output of the <code>show system stack-ports</code> command.

**Defaults** none

**Command Modes** EXEC Privilege

**Supported Modes** All Modes

<b>Command History</b>	<b>Version</b>	<b>Description</b>
	<b>8.3.17.0</b>	Supported on the M I/O Aggregator.

**Related Commands** [show diag](#)— displays the data plane or management plane input and output statistics of the designated component of the designated stack member.

# diag stack-unit

Run offline diagnostics on a stack unit.

**Syntax** `diag stack-unit number {alllevels | level0 | level1 | level2 [verbose no-reboot] | terminate | interactive test <id>}`

<b>Parameters</b>	<b>number</b>	Enter the stack-unit number. The range is from 0 to 5.
	<b>alllevels</b>	Enter the keyword <code>alllevels</code> to run the complete set of offline diagnostic tests.
	<b>level0</b>	Enter the keyword <code>level0</code> to run Level 0 diagnostics. Level 0 diagnostics check for the presence of various components and perform essential path verifications. In addition, they verify the identification registers of the components on the board.
	<b>level1</b>	Enter the keyword <code>level1</code> to run Level 1 diagnostics. Level 1 diagnostics is a smaller set of diagnostic tests with support for automatic partitioning. They perform status/self test for all the components on the board and test their registers for appropriate values. In addition, they perform extensive tests on memory devices (for example, SDRAM, flash, NVRAM, EEPROM, and CPLD) wherever possible. There are no tests on 10G links. At this level, stack ports are shut down automatically.

<b>level2</b>	Enter the keyword <code>level2</code> to run Level 2 diagnostics. Level 2 diagnostics are a full set of diagnostic tests with no support for automatic partitioning. Level 2 diagnostics are used primarily for on-board loopback tests and more extensive component diagnostics. Various components on the board are put into Loopback mode and test packets are transmitted through those components. These diagnostics also perform snake tests using VLAN configurations. To test 10G links, physically remove the unit from the stack.
<b>verbose</b>	Enter the keyword <code>verbose</code> to run the diagnostic in Verbose mode. Verbose mode gives more information in the output than Standard mode.
<b>no-reboot</b>	Enter the keyword <code>no-reboot</code> to avoid automatic rebooting of the chassis after completion of diagnostic execution. Generally, this option is never used because if you run the diagnostic once again without rebooting the chassis, it may cause an issue with the diagnostic results..
<b>terminate</b>	Enter the keyword <code>terminate</code> to stop the execution of the level diag that is already started using the <code>diag stack-unit</code> command. Once this CLI is issued, syslogs indicating the termination of the diag test is displayed. The diag results for the executed tests are stored in the flash directory (TestReport-SU-X.txt).
<b>interactive</b>	Enter the keyword <code>interactive</code> to run some individual diag tests such as <code>POWERLEDTTEST</code> , <code>STATUSLEDTTEST</code> and so on. The help option under the interactive command displays the list of tests that can be run.

**Defaults** none  
**Command Modes** EXEC Privilege  
**Supported Modes** All Modes

Command History	Version	Description
	<b>9.9(0.0)</b>	Introduced on the FN IOM.
	<b>9.4(0.0)</b>	Supported on the FN I/O Aggregator.
	<b>8.3.17.0</b>	Supported on the M I/O Aggregator.

## hardware watchdog

Set the watchdog timer to trigger a reboot and restart the system.

**Syntax** `hardware watchdog`  
**Defaults** Enabled  
**Command Modes** • CONFIGURATION  
**Supported Modes** All Modes

Command History	Version	Description
	<b>9.9(0.0)</b>	Introduced on the FN IOM.
	<b>9.4(0.0)</b>	Supported on the FN I/O Aggregator.
	<b>8.3.17.0</b>	Supported on the M I/O Aggregator.

**Usage Information** This command enables a hardware watchdog mechanism that automatically reboots an Dell Networking OS switch/router with a single unresponsive unit. This is a last resort mechanism intended to prevent a manual power cycle.

# offline stack-unit

Place a stack unit in the offline state.

<b>Syntax</b>	<code>offline stack-unit <i>number</i></code>	
<b>Parameters</b>	<b><i>number</i></b>	Enter the stack-unit number. The range is from 0 to 5.
<b>Defaults</b>	none	
<b>Command Modes</b>	EXEC Privilege	
<b>Supported Modes</b>	All Modes	

<b>Command History</b>	<b>Version</b>	<b>Description</b>
	<b>9.9(0.0)</b>	Introduced on the FN IOM.
	<b>9.4(0.0)</b>	Supported on the FN I/O Aggregator.
	<b>8.3.17.0</b>	Supported on the M I/O Aggregator.

**Usage Information** While executing the offline stack unit CLI, the following warning message is displayed:

```
Dell#offline stack-unit 0
Warning - offline of unit will bring down all the protocols and
the unit will be operationally down, except for running Diagnostics.
Please make sure that stacking/fanout not configured for Diagnostics
execution.
Also reboot/online command is necessary for normal operation after the
offline command is issued.
Proceed with Offline [confirm yes/no]:no
Dell#
```

Make sure that stacking is not configured for Diagnostics execution. Also, reboot/online command is necessary for normal operation after the offline command is issued.

# show diag

View diagnostics information.

<b>Syntax</b>	<code>show diag {information   stack-unit <i>number</i> [detail   periodic   summary]   testcase}</code>	
<b>Parameters</b>	<b>information</b>	Enter the keyword <code>information</code> to view current diagnostics information in the system.
	<b>stack-unit <i>unit-id</i></b>	Enter the keyword <code>stack-unit</code> followed by the <code>unit-id</code> to display information on a specific stack member. The range is from 0 to 5.
	<b>detail</b>	(OPTIONAL) Enter the keyword <code>detail</code> to view detailed diagnostics information.
	<b>summary</b>	(OPTIONAL) Enter the keyword <code>summary</code> to view a summary of the diagnostics information. By default, the summary is displayed.
	<b>testcase</b>	Enter the keyword <code>testcase</code> to view the list of all the diag tests available.
<b>Defaults</b>	Summary	
<b>Command Modes</b>	EXEC Privilege	
<b>Supported Modes</b>	All Modes	

<b>Command History</b>	<b>Version</b>	<b>Description</b>
	<b>8.3.17.0</b>	Supported on the M I/O Aggregator.

**Example 1 (show diag information Command)**

```
Dell#show diag information
Diag information:
Diag software image version:
8-3-17-36
-----
Stack-unit Member 0: Unit diags are terminated (Stackunit Offline).
Stack-unit Member 1: Not present.
Stack-unit Member 2: Not present.
Stack-unit Member 3: Not present.
Stack-unit Member 4: Not present.
Stack-unit Member 5: Not present.
-----
```

**Example 2 (show diag stack-unit Command)**

```
Dell#show diag stackunit 0
Diag status of Stackunit member 0:
-----
Stackunit is currently offline.
Stackunit level0 diag issued at Tue May 15, 2012 11:11:47 AM.
Current diag status:      Unit diags are terminated.
Total number of diags:      17
Number of diags performed:  1
Number of diags passed:     1
Number of diags failed:     0
Number of diags pending:    16
Last Test executed:         POWERRAILSTATUSTEST
Last notification received at: Tue May 15, 2012 11:12:24 AM
-----
```

**Example 3 (show diag testcase stack-unit Command)**

```
Dell#show diag testcase stack-unit 0
***** Navasota Diagnostics Test
*****
Test ID Test Description                               Test Level
-----
1 POWERRAILSTATUSTEST                                 Level0
2 OPTMODSLOTPOWERSTATUSTEST                          Level0
3 TSENSORACCESSTEST                                  Level0
4 RTCPRESENCETEST                                    Level0
5 CPUSDRAMPRESENCETEST                                Level0
6 CPUSDRAMSIZETEST                                    Level0
7 USBAACCESSTEST                                     Level0
8 USBHOSTCONTROLLERACCESSTEST                        Level0
9 SDFLASHACCESSTEST                                   Level0
10 QSFPPPLUSPOWERMODETEST                             Level0
11 CPLDPRESENCETEST                                   Level0
12 FLASHACCESSTEST                                    Level0
13 BOARDREVTEST                                       Level0
14 MGMTPHYPRESENCETEST                                Level0
15 OPTMODTYPEPESTEST                                  Level0
16 QSFPPPLUSPRESENCETEST                              Level0
17 CPUTYPEDETECTTEST                                  Level0
101 RTCFUNCTIONTEST                                   Level1
102 RTCROLLLOVERTEST                                  Level1
103 GPIOACCESSTEST                                    Level1
104 PSOCACCESSTEST                                    Level1
105 PCIEBCM56846ACCESSTEST                            Level1
106 CPUSDRAMACCESSTEST                                Level1
107 CPUSDRAMDATA LINETEST                              Level1
108 CPUSDRAMADDRESS LINETEST                          Level1
109 USBFILECOPYTEST                                   Level1
110 FLASHRWTEST                                       Level1
111 I2CSTRESSTEST                                     Level1
112 AVSPowerCNTRLACCESSTEST                           Level1
113 SERVERPORTPHYACCESSTEST                           Level1
114 SERVERPORTPHYRWTEST                                Level1
115 QSFPPPLUSPHYACCESSTEST                             Level1
116 QSFPPPLUSPHYRWTEST                                 Level1
117 QSFPPPLUSPHYEXTLINKTEST                           Level1
118 QSFPPPLUSEEPROMTEST                               Level1
```

```

119 OPTMODPHYACCESSSTEST          Level1
120 OPTMODPHYRWTEST              Level1
121 OPTMODPHYEXTLINKTEST         Level1
122 OPTMODMODULEEEEEPROMTEST     Level1
123 MGMTPHYACCESSSTEST          Level1
124 SDFLASHFILECOPYSTRESSTEST    Level1
201 QSFPLUSPHYLNKSPEEDTEST      Level2
202 OPTMODPHYLNKSPEEDTEST       Level2
203 MGMTPHYLOOPBACKTEST         Level2
204 MGMTMACLOOPBACKTEST         Level2
205 CPUSNAKESERVERPORTPHYLPBKTEST Level2
206 CPUSNAKESERVERPORTMACLPBKTEST Level2
207 CPUSNAKEQSFPPPHYLPBKTEST    Level2
208 CPUSNAKEQSFPPMACLPBKTEST    Level2
209 CPUSNAKEOPTMODPHYLPBKTEST   Level2
210 CPUSNAKEOPTMODMACLPBKTEST   Level2
Total Diagnostic Testcases in All Levels: 51
***** END
*****

```

**Example 4  
(show diag  
testcase stack-  
unit interactive  
Command)**

```

Dell#show diag testcase stack-unit 0 interactive
***** Navasota Diagnostics Test
*****
Test ID Test Description          Test Level
-----
401 POWERLEDTTEST                Interactive
402 DEBUGLEDTTEST                Interactive
403 STATUSLEDTTEST               Interactive
404 OPTMODLEDCONTROLTEST         Interactive
405 FIXEDLEDCONTROLTEST         Interactive
406 RTCBATTERYTEST               Interactive
407 CPLDRESETTEST                Interactive
408 I2CDEVICESCANTEST            Interactive
409 SERVERPORTPHYEXTLINKTEST     Interactive
410 CPUSNAKEQSFPPEXTLPBKTEST    Interactive
411 CPUSNAKEOPTMODEXTLPBKTEST   Interactive
Total Diagnostic Testcases in Interactive: 11
***** END
*****

```

## show hardware stack-unit

Display the data plane or management plane input and output statistics of the designated component of the designated stack member.

**Syntax**

```

show hardware stack-unit 0-5 {buffer [ unit 0 ] total buffer | buffer unit
0 interface all queue [(0-14) | all] buffer-info} {phy-firmware-version}
{cpu data-plane statistics [stack-port 0-52] | cpu party-bus statistics |
cpu private-mgmt statistics | drops [unit 0-1 ] | stack-port 33-56 | unit
0-0 {counters | details | port-stats [detail] | register}}

```

**Parameters**

- stack-unit 0-5 {command-option}** Enter the keywords `stack-unit` then 0 to 5 to select a particular stack member and then enter one of the following command options to display a collection of data based on the option entered.
- buffer** Enter the keyword `buffer`. To display buffer statistics for a all interface, enter the keyword `interface` followed by the keyword `all`. To display the forwarding plane statistics containing the packet buffer usage per port per stack unit, enter the keyword `unit` then 0 for port-pipe 0, then `port` and the port number (42-53, and then `buffer-info`.
- fpga** Enter the keyword `fpga`, to display fpga details.
- fru** Enter the keyword `fru`, to display fru details.

<b>phy-firmware-version</b>	Each member of the stack is updated automatically with the latest firmware while booting as well as during OIR. To dump the physical firmware version for stack units, enter the keywords <code>phy-firmware-version</code> .
<b>cpu data-plane statistics</b>	Enter the keywords <code>cpu data-plane statistics</code> , optionally followed by the keywords <code>stack port</code> and its number from 0 to 52 to display the data plane statistics, which shows the High Gig (Higig) port raw input/output counter statistics to which the stacking module is connected.
<b>cpu party-bus statistics</b>	Enter the keywords <code>cpu party-bus statistics</code> , to display the Management plane input/output counter statistics of the Private Management interface.
<b>cpu private-mgmt statistics</b>	Enter the keywords <code>cpu private-mgmt statistics</code> , to display the Management plane input/output counter statistics of the Private Management interface.
<b>drops interface interface</b>	Enter the keyword <code>drops</code> to display internal drops on the selected stack member.
<b>stack-port 33-56</b>	Enter the keywords <code>stack-port</code> and a stacking port number to select a stacking port for which to display statistics. Identify the stack port number as you would to identify a 10G port that was in the same place in one of the rear modules. <div style="border-left: 1px solid black; padding-left: 10px; margin-left: 20px;"> <p><b>NOTE:</b> You can identify stack port numbers by physical inspection of the rear modules. The numbering is the same as for the 10G ports. You can also inspect the output of the <code>show system stack-ports</code> command.</p> </div>
<b>unit 0-0 {counters   details   port-stats [detail]   register}</b>	Enter the keyword <code>unit</code> then 0 for port-pipe 0, and then enter one of the following keywords to troubleshoot errors on the selected port-pipe and to give status on why a port is not coming up to register level: <code>counters</code> , <code>details</code> , <code>port-stats [detail]</code> , or <code>register</code> .

- Defaults** none
- Command Modes**
- EXEC
  - EXEC Privilege
- Supported Modes** All Modes

Command History	Version	Description
	<b>9.8(0.0)</b>	Replaced the keyword <code>port</code> with <code>interface</code> .
	<b>8.3.17.0</b>	Supported on the M I/O Aggregator.

**Example (show hardware stack-unit phy-firmware-version Command)**

```
Dell#show hardware stack-unit 1 phy-firmware-version
PortNumber      Status          Programmed Version      SW Version
=====
41               Present         01.05                   01.05
42               Present         01.05                   01.05
43               Present         01.05                   01.05
44               Present         01.05                   01.05
45               Not Present     N/A                     N/A
46               Not Present     N/A                     N/A
47               Not Present     N/A                     N/A
48               Not Present     N/A                     N/A
49               Present         01.06                   01.06
50               Present         01.06                   01.06
51               Present         01.06                   01.06
52               Present         01.06                   01.06
53               Present         01.06                   01.06
54               Present         01.06                   01.06
55               Present         01.06                   01.06
56               Present         01.06                   01.06
Dell#
```

In the above example, the *Status* field represents presence of OPTM ports, *Programmed version* field represents loaded firmware version, and *SW version* represents the SDK version.

**Example (data-plane)**

```
Dell#show hardware stack-unit 1 cpu data-plane statistics

bc pci driver statistics for device:
rxHandle          :7392
noMhdr            :0
noMbuf            :0
noClus            :0
recvd             :7392
dropped           :0
recvToNet         :7392
rxError           :0
rxDatapathErr    :0
rxPkt (COS0)     :0
rxPkt (COS1)     :0
rxPkt (COS2)     :10
rxPkt (COS3)     :0
rxPkt (COS4)     :0
rxPkt (COS5)     :338
rxPkt (COS6)     :0
rxPkt (COS7)     :7044
rxPkt (UNIT0)    :7392
transmitted       :29899
txRequested       :29899
noTxDesc          :0
txError           :0
txReqTooLarge    :0
txInternalError  :0
txDatapathErr    :0
txPkt (COS0)     :0
txPkt (COS1)     :0
txPkt (COS2)     :0
txPkt (COS3)     :0
txPkt (COS4)     :0
txPkt (COS5)     :0
txPkt (COS6)     :0
txPkt (COS7)     :0
txPkt (UNIT0)    :0
Dell#
```

**Example**

```
Dell#show hardware stack-unit 1 cpu party-bus statistics
Input Statistics:
8189 packets, 8076608 bytes
0 dropped, 0 errors
Output Statistics:
366 packets, 133100 bytes
0 errors
Dell#
```

**Example (drops)**

```
Dell#show hard stack-unit 1 drops
UNIT No: 0

Total Ingress Drops : 7448
Total IngMac Drops : 0
Total Mmu Drops : 0
Total EgMac Drops : 0
Total Egress Drops : 16
Dell#
```

**Example (drop summary)**

```
Dell#show hardware stack-unit 1 drops unit 0
UserPort PortNumber      Ingress Drops      IngMac Drops      Total Mmu Drops
EgMac
Drops      Egress Drops
1          1          0          0          0
0
0
2          2          0          0          0
0
0
3          3          0          0          0
0
0
4          4          0          0          0
0
0
5          5          728        0          0
```

```

0
5
6          6          0          0          0
0
7          7          0          0          0
0
8          8          0          0          0
0
9          9          0          0          0
0
10         10         0          0          0
0
0
--More--
Dell#

```

**Example (drop counters)**

```

Dell#show hardware stack-unit 1 unit 0 counters
unit: 0 port: 1 (interface Te 1/1)
Description                                     Value
RX - IPv4 L3 Unicast Frame Counter              0
RX - IPv4 L3 Routed Multicast Packets           0
RX - IPv6 L3 Unicast Frame Counter              0
RX - IPv6 L3 Routed Multicast Packets           0
RX - Unicast Packet Counter                     0
RX - 64 Byte Frame Counter                      336186
RX - 65 to 127 Byte Frame Counter                0
RX - 128 to 255 Byte Frame Counter               0
RX - 256 to 511 Byte Frame Counter              0
RX - 512 to 1023 Byte Frame Counter              0
RX - 1024 to 1518 Byte Frame Counter             0
RX - 1519 to 1522 Byte Good VLAN Frame Counter  0
RX - 1519 to 2047 Byte Frame Counter            0
RX - 2048 to 4095 Byte Frame Counter            0
RX - 4096 to 9216 Byte Frame Counter            0
RX - Good Packet Counter                       336186
RX - Packet/Frame Counter                      336186
RX - Unicast Frame Counter                     0
RX - Multicast Frame Counter                   336186
RX - Broadcast Frame Counter                   0
RX - Byte Counter                              21515904
RX - Control Frame Counter                     0
RX - Pause Control Frame Counter                0
RX - Oversized Frame Counter                   0
RX - Jabber Frame Counter                      0
RX - VLAN Tag Frame Counter                    0
RX - Double VLAN Tag Frame Counter             0
RX - RUNT Frame Counter                        0
RX - Fragment Counter                          0
RX - VLAN Tagged Packets                       0
RX - Ingress Dropped Packet                    0
RX - MTU Check Error Frame Counter             0
RX - PFC Frame Priority 0                      0
RX - PFC Frame Priority 1                      0
RX - PFC Frame Priority 2                      0
RX - PFC Frame Priority 3                      0
RX - PFC Frame Priority 4                      0
RX - PFC Frame Priority 5                      0
RX - PFC Frame Priority 6                      0
RX - PFC Frame Priority 7                      0
RX - Debug Counter 0                          336186
RX - Debug Counter 1                          336186
RX - Debug Counter 2                          0
RX - Debug Counter 3                          0
RX - Debug Counter 4                          0
RX - Debug Counter 5                          336186
RX - Debug Counter 6                          0
RX - Debug Counter 7                          0
RX - Debug Counter 8                          0
TX - 64 Byte Frame Counter                     166
TX - 65 to 127 Byte Frame Counter              112
TX - 128 to 255 Byte Frame Counter             0
TX - 256 to 511 Byte Frame Counter             0
TX - 512 to 1023 Byte Frame Counter            0

```



```

TX - 1024 to 1518 Byte Frame Counter 0
TX - 1519 to 1522 Byte Good VLAN Frame Counter 0
TX - 1519 to 2047 Byte Frame Counter 0
TX - 2048 to 4095 Byte Frame Counter 0
TX - 4096 to 9216 Byte Frame Counter 0
TX - Good Packet Counter 278
TX - Packet/Frame Counter 278
TX - Unicast Frame Counter 0
TX - Multicast Frame Counter 278
TX - Broadcast Frame Counter 0
TX - Byte Counter 18688
TX - Control Frame Counter 0
TX - Pause Control Frame Counter 0
TX - Oversized Frame Counter 0
TX - Jabber Counter 0
TX - VLAN Tag Frame Counter 0
TX - Double VLAN Tag Frame Counter 0
TX - RUNT Frame Counter 0
TX - Fragment Counter 0
TX - PFC Frame Priority 0 0
TX - PFC Frame Priority 1 0
TX - PFC Frame Priority 2 0
TX - PFC Frame Priority 3 0
TX - PFC Frame Priority 4 0
TX - PFC Frame Priority 5 0
TX - PFC Frame Priority 6 0
TX - PFC Frame Priority 7 0
TX - Debug Counter 0 0
TX - Debug Counter 1 0
TX - Debug Counter 2 0
TX - Debug Counter 3 0
TX - Debug Counter 4 0
TX - Debug Counter 5 0
TX - Debug Counter 6 0
TX - Debug Counter 7 0
TX - Debug Counter 8 0
TX - Debug Counter 9 0
TX - Debug Counter 10 0
TX - Debug Counter 11 0

```

```

-----
-----
-----
-----
-----

```

unit: 0 port: 61 (interface Fo 1/60)

Description	Value
RX - IPv4 L3 Unicast Frame Counter	0
RX - IPv4 L3 Routed Multicast Packets	0
RX - IPv6 L3 Unicast Frame Counter	0
RX - IPv6 L3 Routed Multicast Packets	0
RX - Unicast Packet Counter	0
RX - 64 Byte Frame Counter	0
RX - 65 to 127 Byte Frame Counter	0
RX - 128 to 255 Byte Frame Counter	0
RX - 256 to 511 Byte Frame Counter	0
RX - 512 to 1023 Byte Frame Counter	0
RX - 1024 to 1518 Byte Frame Counter	0
RX - 1519 to 1522 Byte Good VLAN Frame Counter	0
RX - 1519 to 2047 Byte Frame Counter	0
RX - 2048 to 4095 Byte Frame Counter	0
RX - 4096 to 9216 Byte Frame Counter	0
RX - Good Packet Counter	0
RX - Packet/Frame Counter	0
RX - Unicast Frame Counter	0
RX - Multicast Frame Counter	0
RX - Broadcast Frame Counter	0
RX - Byte Counter	0
RX - Control Frame Counter	0
RX - Pause Control Frame Counter	0
RX - Oversized Frame Counter	0
RX - Jabber Frame Counter	0
RX - VLAN Tag Frame Counter	0
RX - Double VLAN Tag Frame Counter	0
RX - RUNT Frame Counter	0
RX - Fragment Counter	0
RX - VLAN Tagged Packets	0
RX - Ingress Dropped Packet	0
RX - MTU Check Error Frame Counter	0

```

RX - PFC Frame Priority 0 0
RX - PFC Frame Priority 1 0
RX - PFC Frame Priority 2 0
RX - PFC Frame Priority 3 0
RX - PFC Frame Priority 4 0
RX - PFC Frame Priority 5 0
RX - PFC Frame Priority 6 0
RX - PFC Frame Priority 7 0
RX - Debug Counter 0 0
RX - Debug Counter 1 0
RX - Debug Counter 2 0
RX - Debug Counter 3 0
RX - Debug Counter 4 0
RX - Debug Counter 5 0
RX - Debug Counter 6 0
RX - Debug Counter 7 0
RX - Debug Counter 8 0
TX - 64 Byte Frame Counter 0
TX - 65 to 127 Byte Frame Counter 0
TX - 128 to 255 Byte Frame Counter 0
TX - 256 to 511 Byte Frame Counter 0
TX - 512 to 1023 Byte Frame Counter 0
TX - 1024 to 1518 Byte Frame Counter 0
TX - 1519 to 1522 Byte Good VLAN Frame Counter 0
TX - 1519 to 2047 Byte Frame Counter 0
TX - 2048 to 4095 Byte Frame Counter 0
TX - 4096 to 9216 Byte Frame Counter 0
TX - Good Packet Counter 0
TX - Packet/Frame Counter 0
TX - Unicast Frame Counter 0
TX - Multicast Frame Counter 0
TX - Broadcast Frame Counter 0
TX - Byte Counter 0
TX - Control Frame Counter 0
TX - Pause Control Frame Counter 0
TX - Oversized Frame Counter 0
TX - Jabber Counter 0
TX - VLAN Tag Frame Counter 0
TX - Double VLAN Tag Frame Counter 0
TX - RUNT Frame Counter 0
TX - Fragment Counter 0
TX - PFC Frame Priority 0 0
TX - PFC Frame Priority 1 0
TX - PFC Frame Priority 2 0
TX - PFC Frame Priority 3 0
TX - PFC Frame Priority 4 0
TX - PFC Frame Priority 5 0
TX - PFC Frame Priority 6 0
TX - PFC Frame Priority 7 0
TX - Debug Counter 0 0
TX - Debug Counter 1 0
TX - Debug Counter 2 0
TX - Debug Counter 3 0
TX - Debug Counter 4 0
TX - Debug Counter 5 0
TX - Debug Counter 6 0
TX - Debug Counter 7 0
TX - Debug Counter 8 0
TX - Debug Counter 9 0
TX - Debug Counter 10 0
TX - Debug Counter 11 0

```

### Example (port-statistics)

```

Dell#show hardware stack-unit 1 unit 0 port-stats
ena/ speed/ link auto STP          lrn inter  max  loop
port link duplex scan neg?  state  pause discrd ops face frame back
xe0 !ena 1G FD      SW Yes Forward      Tag    F    GMII 1550
xe1 !ena 1G FD      SW Yes Forward      Tag    F    GMII 1554
xe2 up 1G FD      SW Yes Forward      None   FA    GMII 11996
xe3 !ena 1G FD      SW Yes Forward      Tag    F    GMII 1550
xe4 down 10G FD    SW Yes Block        None   FA    KR 8996
xe5 !ena 1G FD      SW Yes Forward      Tag    F    GMII 1550
xe6 !ena 1G FD      SW Yes Forward      Tag    F    GMII 1550
xe7 !ena 1G FD      SW Yes Forward      Tag    F    GMII 1550
xe8 !ena 1G FD      SW Yes Forward      Tag    F    GMII 1550
xe9 !ena 1G FD      SW Yes Forward      Tag    F    GMII 1550
xe10 down 10G FD   SW Yes Forward      Tag    F    KR 1550
xe11 !ena 1G FD     SW Yes Forward      Tag    F    GMII 1550
xe12 !ena 1G FD     SW Yes Block        None   FA    GMII 11996

```

```

xe13 !ena 1G FD      SW Yes Forward      Tag   F   GMI 1550
xe14 !ena 1G FD      SW Yes Forward      Tag   F   GMI 1550
xe15 !ena 1G FD      SW Yes Forward      Tag   F   GMI 1550
xe16 !ena 1G FD      SW Yes Forward      Tag   F   GMI 1550
xe17 !ena 1G FD      SW Yes Forward      Tag   F   GMI 1550
xe18 down 1G FD      SW Yes Forward      Tag   F   GMI 1550
xe19 !ena 1G FD      SW Yes Forward      Tag   F   GMI 1550
xe20 down 1G FD      SW Yes Forward      Tag   F   GMI 1550
--More--
Dell#

```

**Example  
(register)**

```

Dell#show hardware stack-unit 0 unit 0 register
0x0f180d34 ALTERNATE_EMIRROR_BITMAP_PARITY_CONTROL.ipipe0 = 0x00000001
0x0f180d35 ALTERNATE_EMIRROR_BITMAP_PARITY_STATUS_INTR.ipipe0 = 0x00000000
0x0f180d36 ALTERNATE_EMIRROR_BITMAP_PARITY_STATUS_NACK.ipipe0 = 0x00000000
0x0018070c ARB_EOP_DEBUG.ipipe0 = 0x00000000
0x00180312 ARB_RAM_DBGCTRL.ipipe0 = 0x00000000
0x03300000 ASF_PORT_SPEED.cpu0 = 0x00000000
0x03322000 ASF_PORT_SPEED.xe0 = 0x00000000
0x03326000 ASF_PORT_SPEED.xe1 = 0x00000000
0x0332a000 ASF_PORT_SPEED.xe2 = 0x00000007
0x0332e000 ASF_PORT_SPEED.xe3 = 0x00000000
0x03323000 ASF_PORT_SPEED.xe4 = 0x00000000
0x03327000 ASF_PORT_SPEED.xe5 = 0x00000000
0x0332b000 ASF_PORT_SPEED.xe6 = 0x00000000
0x0332f000 ASF_PORT_SPEED.xe7 = 0x00000000
0x03324000 ASF_PORT_SPEED.xe8 = 0x00000000
0x03328000 ASF_PORT_SPEED.xe9 = 0x00000000
0x0332c000 ASF_PORT_SPEED.xe10 = 0x00000000
0x03330000 ASF_PORT_SPEED.xe11 = 0x00000000
0x03325000 ASF_PORT_SPEED.xe12 = 0x00000000
0x03329000 ASF_PORT_SPEED.xe13 = 0x00000000
0x0332d000 ASF_PORT_SPEED.xe14 = 0x00000000
0x03331000 ASF_PORT_SPEED.xe15 = 0x00000000
0x03332000 ASF_PORT_SPEED.xe16 = 0x00000000
0x03336000 ASF_PORT_SPEED.xe17 = 0x00000000
0x0333a000 ASF_PORT_SPEED.xe18 = 0x00000000
0x0333e000 ASF_PORT_SPEED.xe19 = 0x00000000
0x03333000 ASF_PORT_SPEED.xe20 = 0x00000000
0x03337000 ASF_PORT_SPEED.xe21 = 0x00000000
0x0333b000 ASF_PORT_SPEED.xe22 = 0x00000000
0x0333f000 ASF_PORT_SPEED.xe23 = 0x00000000
0x03334000 ASF_PORT_SPEED.xe24 = 0x00000000
0x03338000 ASF_PORT_SPEED.xe25 = 0x00000000
0x0333c000 ASF_PORT_SPEED.xe26 = 0x00000000
0x03340000 ASF_PORT_SPEED.xe27 = 0x00000000
0x03335000 ASF_PORT_SPEED.xe28 = 0x00000000
0x03339000 ASF_PORT_SPEED.xe29 = 0x00000000
!-----output truncated -----!

```

**Example (unit  
details)**

```

Dell#show hardware stack-unit 0 unit 0 details
*****
The total no of FP & CSF Devices in the Card is 1
The total no of FP Devices in the Card is 1
The total no of CSF Devices in the Card is 0
The number of ports in device 0 is - 49
The number of Hg ports in devices 0 is - 1
The CPU Port of the device is 0
The staring unit no the SWF in the device is 0
*****
bcmLinkMonStatusShow: The Current Link Status Is
Front End Link Status 0x20000000000000000000000000000000
Front End Port Present Status 0x00000000000000000000000000000000
Back Plane Link Status 0x00000000
*****
Link Status of all the ports in the Device - 0
The linkStatus of Front End Port 1 is FALSE
The linkStatus of Front End Port 2 is FALSE
The linkStatus of Front End Port 3 is TRUE
The linkStatus of Front End Port 4 is FALSE
The linkStatus of Front End Port 5 is FALSE
The linkStatus of Front End Port 6 is FALSE
The linkStatus of Front End Port 7 is FALSE
The linkStatus of Front End Port 8 is FALSE
The linkStatus of Front End Port 9 is FALSE
The linkStatus of Front End Port 10 is FALSE
The linkStatus of Front End Port 11 is FALSE

```

```

The linkStatus of Front End Port 12 is FALSE
The linkStatus of Front End Port 13 is FALSE
The linkStatus of Front End Port 14 is FALSE
The linkStatus of Front End Port 15 is FALSE
The linkStatus of Front End Port 16 is FALSE
The linkStatus of Front End Port 17 is FALSE
The linkStatus of Front End Port 18 is FALSE
The linkStatus of Front End Port 19 is FALSE
The linkStatus of Front End Port 20 is FALSE
The linkStatus of Front End Port 21 is FALSE
The linkStatus of Front End Port 22 is FALSE
The linkStatus of Front End Port 23 is FALSE
The linkStatus of Front End Port 24 is FALSE
The linkStatus of Front End Port 25 is FALSE
The linkStatus of Front End Port 26 is FALSE
The linkStatus of Front End Port 27 is FALSE
The linkStatus of Front End Port 28 is FALSE
The linkStatus of Front End Port 29 is FALSE
The linkStatus of Front End Port 30 is FALSE
The linkStatus of Front End Port 31 is FALSE
The linkStatus of Front End Port 32 is FALSE
The linkStatus of Front End Port 37 is FALSE
!----- output truncated -----!

```

### Example (buffer)

```

Dell#show hardware stack-unit 0 buffer total-buffer
Dell#sh hardware stack-unit 0 buffer total-buffer
Total Buffers allocated per Stack-Unit 46080

```

### Example (Queue2/Buffer-Info)

```

Dell#show hardware stack-unit 1 buffer unit 0 interface all queue 6 buffer-info
      Buffer Stats for Front End Ports
=====
----- Buffer Stats for Interface Te 1/1 Queue 6 -----
Maximum Shared Limit: 7667
Default Packet Buffer allocate for the Queue: 8
Used Packet Buffer: 0
----- Buffer Stats for Interface Te 1/2 Queue 6 -----
Maximum Shared Limit: 7667
Default Packet Buffer allocate for the Queue: 8
Used Packet Buffer: 0
----- Buffer Stats for Interface Te 1/3 Queue 6 -----
Maximum Shared Limit: 7667
Default Packet Buffer allocate for the Queue: 8
Used Packet Buffer: 0
----- Buffer Stats for Interface Te 1/4 Queue 6 -----
Maximum Shared Limit: 7667
Default Packet Buffer allocate for the Queue: 8
Used Packet Buffer: 0
----- Buffer Stats for Interface Te 1/5 Queue 6 -----
Maximum Shared Limit: 7667
Default Packet Buffer allocate for the Queue: 8
Used Packet Buffer: 0
----- Buffer Stats for Interface Te 1/6 Queue 6 -----
Maximum Shared Limit: 7667
Default Packet Buffer allocate for the Queue: 8
Used Packet Buffer: 0
<output truncated for brevity>

```

### Example (queue buffer)

```

Dell(conf)#show hardware stack-unit 0 buffer unit 0 port 1 queue 2 buffer-info
----- Buffer Stats for Unit 0 Port 1 Queue 2 -----
Maximum Shared Limit: 30720
Default Packet Buffer allocate for the Queue: 8
Used Packet Buffer: 0

```

### Related Commands

- [show interfaces stack-unit](#) — displays information on all interfaces on a specific stack member.
- [show processes cpu](#) — displays CPU usage information based on running processes.
- [show system stack-ports](#) — displays information about the stacking ports on all switches in the stack.
- [show system](#) — displays the current status of all stack members or a specific member.

# show hardware counters interface

Display the counter information for a specific interface.

- Syntax** `show hardware counters interface interface`
- Parameters**
- counters** Enter the keywords `counters` to display counter value for the specified stack-member the port-pipe.
  - interface *interface*** Enter any of the following keywords and slot/port or number information:
    - For a 10-Gigabit Ethernet interface, enter the keyword `TenGigabitEthernet` then the slot/port information.
    - For a 40-Gigabit Ethernet interface, enter the keyword `fortyGigE` then the slot/port information.
- Defaults** none
- Command Modes**
- EXEC
  - EXEC Privilege
- Command History**
- This guide is platform-specific. For command information about other platforms, refer to the relevant *Dell Networking OS Command Line Reference Guide*.

The following is a list of the Dell Networking OS version history for this command.

Version	Description
9.8(0.0)	Introduced on the M I/O Aggregator.

## Example

```
Dell#show hardware counters interfac tengigabitethernet 5/1
unit: 0 port: 2 (interface Te 5/1)
Description                                     Value
RX - IPV4 L3 Unicast Frame Counter              0
RX - IPV4 L3 Routed Multicast Packets           0
RX - IPV6 L3 Unicast Frame Counter              0
RX - IPV6 L3 Routed Multicast Packets           0
RX - Unicast Packet Counter                     0
RX - 64 Byte Frame Counter                      0
RX - 65 to 127 Byte Frame Counter               0
RX - 128 to 255 Byte Frame Counter              0
RX - 256 to 511 Byte Frame Counter              0
RX - 512 to 1023 Byte Frame Counter             0
RX - 1024 to 1518 Byte Frame Counter            0
RX - 1519 to 1522 Byte Good VLAN Frame Counter 0
RX - 1519 to 2047 Byte Frame Counter           0
RX - 2048 to 4095 Byte Frame Counter           0
RX - 4096 to 9216 Byte Frame Counter           0
RX - Good Packet Counter                       0
RX - Packet/Frame Counter                      0
RX - Unicast Frame Counter                     0
RX - Multicast Frame Counter                   0
RX - Broadcast Frame Counter                   0
RX - Byte Counter                              0
RX - Control Frame Counter                     0
RX - Pause Control Frame Counter               0
RX - Oversized Frame Counter                   0
RX - Jabber Frame Counter                      0
RX - VLAN Tag Frame Counter                    0
RX - Double VLAN Tag Frame Counter             0
RX - RUNT Frame Counter                        0
RX - Fragment Counter                          0
RX - VLAN Tagged Packets                       0
RX - Ingress Dropped Packet                   0
RX - MTU Check Error Frame Counter             0
RX - PFC Frame Priority 0                      0
RX - PFC Frame Priority 1                      0
```

```

RX - PFC Frame Priority 2          0
RX - PFC Frame Priority 3          0
RX - PFC Frame Priority 4          0
RX - PFC Frame Priority 5          0
RX - PFC Frame Priority 6          0
RX - PFC Frame Priority 7          0
RX - Debug Counter 0               0
RX - Debug Counter 1               0
RX - Debug Counter 2               0
<output truncated for brevity>

```

## show hardware buffer interface

Display buffer statistics for a specific interface.

**Syntax** `show hardware buffer interface interface{priority-group { id | all } | queue { id| all } ] buffer-info`

**Parameters**

**interface**  
**interface** Enter any of the following keywords and slot/port or number information:

- For a 10-Gigabit Ethernet interface, enter the keyword `TenGigabitEthernet` then the slot/port information.
- For a 40-Gigabit Ethernet interface, enter the keyword `fortyGigE` then the slot/port information.

**priority-group** Identifier of the priority group in the range of 0 to 7.

**queue** Enter the keyword `queue` followed by *id* for specific queue or keyword `all`.

**buffer-info** To display total buffer information for the interface, enter the keywords `buffer-info`.

**Command Modes** EXEC  
EXEC Privilege

**Command History**

Version	Description
9.9(0.0)	Introduced on the FN IOM.
9.8(0.0)	Introduced on the M I/O Aggregator and FN I/O Aggregator.

**Example displaying total-buffer information for the interface**

```

Dell# show hardware buffer interface tengigabitethernet 1/1 buffer-info
---- Buffer Stats for Interface Te 1/1 ----
Maximum Shared Limit for the Interface: 38336
Default Packet Buffer allocate for the Interface: 120
Used Packet Buffer for the Interface: 0

```

**Example displaying priority-group range**

```

Dell#show hardware buffer interface tengigabitethernet 1/1 priority-group 0
buffer-info
---- Buffer stats for unit: 0 port: 1 (interface Te 1/1) ----
-----
PG# PRIORITIES          ALLOTED (CELLS)          COUNTER (CELLS)
          MIN    SHARED    MODE    HDRM    MIN    SHARED    HDRM
-----
0  -                61440    0          STATIC  174    0     0     0
-----
Dell#

```

**Example displaying queue range**

```

Dell#show hardware buffer interface tengigabitethernet 1/1 queue all buffer-info
---- Buffer Stats for Interface Te 1/1 Queue 0 ----
Maximum Shared Limit: 29514
Default Packet Buffer allocate for the Queue: 8

```

```

Used Packet Buffer: 0
----- Buffer Stats for Interface Te 1/1 Queue 1 -----
Maximum Shared Limit: 29514
Default Packet Buffer allocate for the Queue: 8
Used Packet Buffer: 0
----- Buffer Stats for Interface Te 1/1 Queue 2 -----
Maximum Shared Limit: 29514
Default Packet Buffer allocate for the Queue: 8
Used Packet Buffer: 0
----- Buffer Stats for Interface Te 1/1 Queue 3 -----
Maximum Shared Limit: 29514
Default Packet Buffer allocate for the Queue: 8
Used Packet Buffer: 0
----- Buffer Stats for Interface Te 1/1 Queue 4 -----
Maximum Shared Limit: 29514
Default Packet Buffer allocate for the Queue: 8
Used Packet Buffer: 0
----- Buffer Stats for Interface Te 1/1 Queue 5 -----
Maximum Shared Limit: 29514
Default Packet Buffer allocate for the Queue: 8
Used Packet Buffer: 0
----- Buffer Stats for Interface Te 1/1 Queue 6 -----
Maximum Shared Limit: 29514
Default Packet Buffer allocate for the Queue: 8
Used Packet Buffer: 0
----- Buffer Stats for Interface Te 1/1 Queue 7 -----
Maximum Shared Limit: 29514
Default Packet Buffer allocate for the Queue: 8
Used Packet Buffer: 0
----- Buffer Stats for Interface Te 1/1 Queue 8 -----
Maximum Shared Limit: 29514
Default Packet Buffer allocate for the Queue: 8
Used Packet Buffer: 0
----- Buffer Stats for Interface Te 1/1 Queue 9 -----
Maximum Shared Limit: 29514
Default Packet Buffer allocate for the Queue: 8
Used Packet Buffer: 0
----- Buffer Stats for Interface Te 1/1 Queue 10 -----
Maximum Shared Limit: 29514
Default Packet Buffer allocate for the Queue: 8
Used Packet Buffer: 0
----- Buffer Stats for Interface Te 1/1 Queue 11 -----
Maximum Shared Limit: 29514
Default Packet Buffer allocate for the Queue: 8

<output truncated for brevity>

```

## show hardware system-flow

Display Layer 2 ACL or QoS data for the selected stack member and stack member port-pipe.

<b>Syntax</b>	<code>show hardware system-flow layer2 stack-unit 0-5 port-set 0-0 [counters]</code>	
<b>Parameters</b>	<b>acl   qos</b>	For the selected stack member and stack member port-pipe, display which system flow entry the packet hits and what queue the packet takes as it dumps the raw system flow tables.
	<b>stack-unit 0-5</b>	Enter the keywords <code>stack-unit</code> then 0 to 5 to select a stack member ID.
	<b>port-set 0-0 [counters]</b>	Enter the keywords <code>port-set</code> with a port-pipe number—0. (OPTIONAL) Enter the keyword <code>counters</code> to display hit counters for the selected ACL or QoS option.
<b>Defaults</b>	none	
<b>Command Modes</b>	EXEC Privilege	
<b>Supported Modes</b>	All Modes	

**Command History**

Version	Description
8.3.17.0	Supported on the M I/O Aggregator.

**Example**

```
Dell#show hardware system-flow layer2 stack-unit 0 port-set 0 counters
-----
EntryId  Description                                     #HITS
-----
2048     STP BPDU Redirects                               0
2047     LLDP BPDU Redirects                             164904
2045     LACP traffic Redirects                           0
2044     GVRP traffic Redirects                           0
2043     ARP Reply Redirects                              0
2042     802.1x frames Redirects                          0
2041     VRRP frames Redirects                            0
2040     IPv6VRRP frames Redirects                        0
2039     GRAT ARP                                          0
2036     IPv6 Mcast Control Traffic                       128840
2000     VLT ARP SYNC Frames                              0
1999     ICL Hellos                                        0
1998     ICL MAC SYNC Frames                              0
1997     VLT Tunneled STP Frames                          0
1995     DROP Cases                                       43207
1917     L3 Term Traffic ClassID 1 to Q6                  0
1916     L3 CPU Bound Traffic ClassId 2 to Q5             0
1915     Unknown MCAST Packets                            0
1792     BGP with TTL1, L4 SRC port Redirects             0
1791     BGP with TTL1, L4 DST Port Redirects            0
25
Dell#
```

**Example (non-counters)**

```
Dell#show hardware system-flow layer2 stack-unit 0 port-set 0

##### FP Entry for redirecting STP BPDU to CPU Port
#####
EID 2048: gid=1,
        slice=15, slice_idx=0x00, prio=0x800, flags=0x82, Installed
        tcam: color_indep=0, higig=0, higig_mask=0,
        KEY=0x00000000 00000000 00000000 0180c200 00000000 00000000
00000000
, FPF4=0x00
        MASK=0x00000000 00000000 00000000 ffffffff ffff0000 00000000
00000000
,          0x00
        action={act=Drop, param0=0(0x00), param1=0(0x00)},
        action={act=CosQCpuNew, param0=7(0x07), param1=0(0x00)},
        action={act=CopyToCpu, param0=0(0x00), param1=0(0x00)},
        action={act=UpdateCounter, param0=1(0x01), param1=0(0x00)},
        meter=NULL,
        counter={idx=0, mode=0x01, entries=1}

##### FP Entry for redirecting LLDP BPDU to RSM
#####
EID 2047: gid=1,
        slice=15, slice_idx=0x01, prio=0x7ff, flags=0x82, Installed
        tcam: color_indep=0, higig=0, higig_mask=0,
        KEY=0x00000000 00000000 00000000 0180c200 000e0000 00000000
00000000
, FPF4=0x00
        MASK=0x00000000 00000000 00000000 ffffffff ffff0000 00000000
00000000
,          0x00
        action={act=Drop, param0=0(0x00), param1=0(0x00)},
        action={act=CosQCpuNew, param0=7(0x07), param1=0(0x00)},
        action={act=CopyToCpu, param0=0(0x00), param1=0(0x00)},
        action={act=UpdateCounter, param0=1(0x01), param1=0(0x00)},
        meter=NULL,
        counter={idx=1, mode=0x01, entries=1}
```



```

##### FP Entry for redirecting LACP traffic to CPU Port
#####
EID 2045: gid=1,
        slice=15, slice_idx=0x02, prio=0x7fd, flags=0x82, Installed
        tcam: color_indep=0, higig=0, higig_mask=0,
        KEY=0x00000000 00000000 00000000 0180c200 00020000 00000000
00000000
, FPF4=0x00
        MASK=0x00000000 00000000 00000000 ffffffff ffff0000 00000000
00000000
, 0x00
        action={act=Drop, param0=0(0x00), param1=0(0x00)},
        action={act=CosQCpuNew, param0=7(0x07), param1=0(0x00)},
        action={act=CopyToCpu, param0=0(0x00), param1=0(0x00)},
        action={act=UpdateCounter, param0=1(0x01), param1=0(0x00)},
        meter=NULL,
        counter={idx=2, mode=0x01, entries=1}

##### FP Entry for redirecting GVRP traffic to RSM
#####
EID 2044: gid=1,
        slice=15, slice_idx=0x03, prio=0x7fc, flags=0x82, Installed
        tcam: color_indep=0, higig=0, higig_mask=0,
        KEY=0x00000000 00000000 00000000 0180c200 00210000 00000000
00000000
, FPF4=0x00
        MASK=0x00000000 00000000 00000000 ffffffff ffff0000 00000000
00000000
, 0x00
        action={act=Drop, param0=0(0x00), param1=0(0x00)},
        action={act=CosQCpuNew, param0=7(0x07), param1=0(0x00)},
        action={act=CopyToCpu, param0=0(0x00), param1=0(0x00)},
        action={act=UpdateCounter, param0=1(0x01), param1=0(0x00)},
        meter=NULL,
        counter={idx=3, mode=0x01, entries=1}

##### FP Entry for redirecting ARP Replies to RSM
#####
EID 2043: gid=1,
        slice=15, slice_idx=0x04, prio=0x7fb, flags=0x82, Installed
        tcam: color_indep=0, higig=0, higig_mask=0,
        KEY=0x00000000 00000000 00000000 00000000 00000000 00000806
00001600
, FPF4=0x00
        MASK=0x00000000 00000000 00000000 00000000 00000000
0000ffff 00001600
, 0x00
        action={act=Drop, param0=0(0x00), param1=0(0x00)},
        action={act=CosQCpuNew, param0=6(0x06), param1=0(0x00)},
        action={act=CopyToCpu, param0=0(0x00), param1=0(0x00)},
        action={act=UpdateCounter, param0=1(0x01), param1=0(0x00)},
!----- output truncated -----!

```

## show hardware buffer-stats-snapshot

Displays buffer statistics tracking resource information for a specific interface.

**Syntax** Dell#show hardware stack-unit <id> buffer-stats-snapshot unit <id> resource x

**Parameters**

**buffer-info** buffer-info Displays total buffer information for a group, where x can be one of the following:

- All - Displays ingress and egress device, port, and queue snapshots
- Interface all queue {all} - egress queue-level snapshot for both unicast and multicast packets

- Interface all queue ucast {id | all} - egress queue-level snapshot for unicast packets only
- Interface all queue mcast {id | all} - egress queue-level snapshot for multicast packets only
- Interface all prio-group {id | all} - ingress priority-group level snapshot

**buffer-stats-snapshot unit number**

Display the historical snapshot of buffer statistical values unit Enter the keyword unit along with a port-pipe number. The range is from 0 to 0.

**Command Modes** EXEC  
EXEC Privilege

**Command History**

Version	Description
9.8(0.0)	Introduced on the M I/O Aggregator and the FN I/O Aggregator.

**Usage Information**

<Interface><slot/port>-Queue ucast/mcast — Displays the total unicast/multicast buffer usage on per-port per-queue basis. For CPU port, counters for queues 0 to11 displays and there is no differentiation between unicast and multicast queues.

**Example displaying egress queue-level snapshot for both unicast and multicast packets for the specific interface**

```
Dell# show hardware buffer-stats-snapshot resource interface fortyGigE 1/1 queue all
Unit 1 unit: 0 port: 1 (interface Fo 1/1)
-----
Q# TYPE      Q#      TOTAL BUFFERED CELLS
-----
UCAST      0        0
UCAST      1        0
UCAST      2        0
UCAST      3        0
UCAST      4        0
UCAST      5        0
UCAST      6        0
UCAST      7        0
UCAST      8        0
UCAST      9        0
UCAST     10        0
UCAST     11        0
MCAST      0        0
MCAST      1        0
MCAST      2        0
MCAST      3        0
MCAST      4        0
MCAST      5        0
MCAST      6        0
MCAST      7        0
MCAST      8        0
```

**Example displaying egress queue-level snapshot for unicast packets for the specific interface**

```
Del#show hardware buffer-stats-snapshot resource interface fortyGigE 0/0
queue ucast 10
Unit 0 unit: 0 port: 1 (interface Fo 0/0)
-----
Q# TYPE      Q#      TOTAL BUFFERED CELLS
-----
UCAST      10       0
```

```
Dell#show hardware buffer-stats-snapshot resource interface fortyGigE 0/0 queue ucast all
Unit 0 unit: 0 port: 1 (interface Fo 0/0)
-----
Q# TYPE      Q#      TOTAL BUFFERED CELLS
-----
```

```

UCAST      0      0
UCAST      1      0
UCAST      2      0
UCAST      3      0
UCAST      4      0
UCAST      5      0
UCAST      6      0
UCAST      7      0
UCAST      8      0
UCAST      9      0
UCAST     10      0
UCAST     11      0

```

**Example displaying egress queue-level snapshot for multicast packets for the specific interface**

```

Dell#show hardware buffer-stats-snapshot resource interface fortyGigE
0/0 queue mcast 3
Unit 1 unit: 0 port: 1 (interface Fo 0/0)
-----
Q# TYPE      Q#      TOTAL BUFFERED CELLS
-----
MCAST      3      0

```

```

Dell#show hardware buffer-stats-snapshot resource interface fortyGigE
0/0 queue mcast all

Unit 0 unit: 0 port: 1 (interface Fo 0/0)
-----
Q# TYPE      Q#      TOTAL BUFFERED CELLS
-----
MCAST      0      0
MCAST      1      0
MCAST      2      0
MCAST      3      0
MCAST      4      0
MCAST      5      0
MCAST      6      0
MCAST      7      0
MCAST      8      0

```

**Example displaying ingress priority-group level snapshot for the specific interface**

```

Dell#show hardware buffer-stats-snapshot resource interface fortyGigE
1/1 priority-group 7

Unit 1 unit: 0 port: 1 (interface Fo 1/1)
-----
PG#      SHARED CELLS      HEADROOM CELLS
-----
7        0                0

```

```

Dell#show hardware buffer-stats-snapshot resource interface fortyGigE
1/1 priority-group all

Unit 1 unit: 0 port: 1 (interface Fo 1/1)
-----
PG#      SHARED CELLS      HEADROOM CELLS
-----
0        0                0
1        0                0
2        0                0
3        0                0
4        0                0
5        0                0
6        0                0
7        0                0

```

```

Dell#show hardware buffer-stats-snapshot resource interface fortyGigE
0/0 priority-group 7

```

```

Unit 0 unit: 0 port: 1 (interface Fo 0/0)
-----
PG#      SHARED CELLS      HEADROOM CELLS
-----
7        0                0

Dell#show hardware buffer-stats-snapshot resource interface fortyGigE
0/0 priority-group all

Unit 0 unit: 0 port: 1 (interface Fo 0/0)
-----
PG#      SHARED CELLS      HEADROOM CELLS
-----
0        0                0
1        0                0
2        0                0
3        0                0
4        0                0
5        0                0
6        0                0
7        0                0

```

## show hardware stack-unit buffer-stats-snapshot (Total Buffer Information)

View the buffer statistics tracking resource information depending on the type of buffer information, such as device-level details, port-level counters, queue-based snapshots, or priority group-level snapshot in the egress and ingress direction of traffic.

### Syntax

```
show hardware stack-unit {id} buffer-stats-snapshot unit {id} resource
interface all {priority-group { id | all } | queue { ucast{id | all}{ mcast
{id | all} | all}}
```

### Parameters

- |   |  |
|---|--|
| <b>stack-unit <i>stack-unit-number</i></b>      | Unique ID of the stack unit to select a particular stack member and then enter one of the following command options to display a collection of data based on the option entered. The range is from 0 to 11.  |
| <b>buffer-stats-snapshot unit <i>number</i></b> | Display the historical snapshot of buffer statistical values unit Enter the keyword <code>unit</code> along with a port-pipe number. The range is from 0 to 0.   |
| <b>buffer-info</b>                              | <p>buffer-info Displays total buffer information for a group, where <i>x</i> can be one of the following:</p> <ul style="list-style-type: none"> <li>• All - Displays ingress and egress device, port, and queue snapshots</li> <li>• Interface all queue {all} - egress queue-level snapshot for both unicast and multicast packets</li> <li>• Interface all queue ucast {id   all} - egress queue-level snapshot for unicast packets only</li> <li>• Interface all queue mcast {id   all} - egress queue-level snapshot for multicast packets only</li> <li>• Interface all prio-group {id   all} - ingress priority-group level snapshot</li> </ul> |

### Command Modes

EXEC  
EXEC Privilege

## Command History

Version	Description
9.8(0.0)	Introduced on the MI/O Aggregator, and FN I/O Aggregator.

## Usage Information

The following information is displayed based on the buffer-info type, such as device-level details, queue-based snapshots, or priority group-level snapshot in the egress and ingress direction of traffic:

- Device-ingress – Displays total buffer accounting usage for the unit.
- Device-egress – Display total buffer usage for the unit, total multicast buffer usage for the unit and also on per-service-pool basis. Counters will be displayed for the 2 service-pools – one for normal traffic and other for DCB traffic.

When the buffer-stats-snapshot is disabled, the following informational message is displayed when you run the show command: %Info: Buffer-stats-snapshot feature is disabled.

## Example

```
Dell#show hardware stack-unit 1 buffer-stats-snapshot unit 3 resource
interface all queue mcast 3
Unit 1 unit: 3 port: 1 (interface Fo 1/144)
-----
Q# TYPE      Q#      TOTAL BUFFERED CELLS
-----
MCAST      3        0

Unit 1 unit: 3 port: 5 (interface Fo 1/148)
-----
Q# TYPE      Q#      TOTAL BUFFERED CELLS
-----
MCAST      3        0

Unit 1 unit: 3 port: 9 (interface Fo 1/152)
-----
Q# TYPE      Q#      TOTAL BUFFERED CELLS
-----
MCAST      3        0

Unit 1 unit: 3 port: 13 (interface Fo 1/156)
-----
Q# TYPE      Q#      TOTAL BUFFERED CELLS
-----
MCAST      3        0

Unit 1 unit: 3 port: 17 (interface Fo 1/160)
-----
Q# TYPE      Q#      TOTAL BUFFERED CELLS
-----
MCAST      3        0

Unit 1 unit: 3 port: 21 (interface Fo 1/164)
-----
Q# TYPE      Q#      TOTAL BUFFERED CELLS
-----
MCAST      3        0

Unit 1 unit: 3 port: 25 (interface Fo 1/168)
-----
Q# TYPE      Q#      TOTAL BUFFERED CELLS
-----
MCAST      3        0

Unit 1 unit: 3 port: 29 (interface Fo 1/172)
-----
Q# TYPE      Q#      TOTAL BUFFERED CELLS
-----
MCAST      3        0

Unit 1 unit: 3 port: 33 (interface Fo 1/176)
-----
Q# TYPE      Q#      TOTAL BUFFERED CELLS
-----
```

```

MCAST      3      0

Unit 1 unit: 3 port: 37 (interface Fo 1/180)
-----
Q# TYPE      Q#      TOTAL BUFFERED CELLS
-----

```

## show hardware drops

Displays internal drops on the specified interface or for a range of interface.

**Syntax** `show hardware drops interface interface`

**Parameters**

**interface** Enter any of the following keywords and slot/port or slot/port-range or number information:

- For a 10-Gigabit Ethernet interface, enter the keyword `TenGigabitEthernet` then the slot/port information.
- For a 40-Gigabit Ethernet interface, enter the keyword `fortyGigE` then the slot/port information.

**drops** Enter the keyword `drops` to display internal drops.

**Command Modes** EXEC  
EXEC Privilege

Command History	Version	Description
	<b>9.9(0.0)</b>	Introduced on the FN IOM.
	<b>9.8(0.0)</b>	Introduced on the M I/O Aggregator and the FN I/O Aggregator.

**Example displaying internal drops for the specific interface**

```

Dell#show hardware drops interface tengigabitethernet 2/1

Drops in Interface Te 2/1:
--- Ingress Drops ---
Ingress Drops                : 0
IBP CBP Full Drops           : 0
PortSTPnotFwd Drops         : 0
IPv4 L3 Discards             : 0
Policy Discards              : 0
Packets dropped by FP        : 0
(L2+L3) Drops                : 0
Port bitmap zero Drops       : 0
Rx VLAN Drops                : 0
--- Ingress MAC counters---
Ingress FCSDrops             : 0
Ingress MTUExceeds           : 0
--- MMU Drops ---
Ingress MMU Drops            : 0
HOL DROPS (TOTAL)            : 0
HOL DROPS on COS0            : 0
HOL DROPS on COS1            : 0
HOL DROPS on COS2            : 0
HOL DROPS on COS3            : 0
HOL DROPS on COS4            : 0
HOL DROPS on COS5            : 0
HOL DROPS on COS6            : 0
HOL DROPS on COS7            : 0
HOL DROPS on COS8            : 0
HOL DROPS on COS9            : 0
HOL DROPS on COS10           : 0
HOL DROPS on COS11           : 0

```

```

HOL DROPS on COS12      : 0
HOL DROPS on COS13      : 0
HOL DROPS on COS14      : 0
HOL DROPS on COS15      : 0
HOL DROPS on COS16      : 0
HOL DROPS on COS17      : 0
TxPurge CellErr        : 0
Aged Drops              : 0
  --- Egress MAC counters---
Egress FCS Drops        : 0
  --- Egress FORWARD PROCESSOR Drops ---
IPv4 L3UC Aged & Drops  : 0
TTL Threshold Drops     : 0
INVALID VLAN CNTR Drops : 0
L2MC Drops              : 0
PKT Drops of ANY Conditions : 0
Hg MacUnderflow         : 0
TX Err PKT Counter      : 0
  --- Error counters---
Internal Mac Transmit Errors : 0
Unknown Opcodes         : 0
Internal Mac Receive Errors : 0

```

**Example  
displaying  
internal drops for  
FC port**

```

Dell(conf)#do show hardware drops interface fibreChannel 0/49

Drops in Interface Fc 0/49:
  --- Ingress Drops ---
Ingress Drops          : 10
IBP CBP Full Drops     : 0
PortSTPnotFwd Drops   : 0
IPv4 L3 Discards       : 0
Policy Discards        : 0
Packets dropped by FP  : 10
(L2+L3) Drops          : 0
Port bitmap zero Drops : 1
Rx VLAN Drops          : 1
  --- Ingress MAC counters---
Ingress FCS Drops      : 0
Ingress MTUExceeds    : 0
  --- MMU Drops ---
Ingress MMU Drops      : 0
Ingress Drops Bytes    : 0
HOL DROPS (TOTAL)     : 0
HOL DROPS on COS0     : 0
HOL DROPS on COS1     : 0
HOL DROPS on COS2     : 0
HOL DROPS on COS3     : 0
HOL DROPS on COS4     : 0
HOL DROPS on COS5     : 0
HOL DROPS on COS6     : 0
HOL DROPS on COS7     : 0
HOL DROPS on COS8     : 0
HOL DROPS on COS9     : 0
HOL DROPS on COS10    : 0
HOL DROPS on COS11    : 0
HOL DROPS on COS12    : 0
HOL DROPS on COS13    : 0
HOL DROPS on COS14    : 0
TxPurge CellErr       : 0
Aged Drops            : 0
  --- Egress MAC counters---
Egress FCS Drops      : 0
  --- Egress FORWARD PROCESSOR Drops ---
IPv4 L3UC Aged & Drops : 0
TTL Threshold Drops   : 0
INVALID VLAN CNTR Drops : 0
L2MC Drops            : 0
PKT Drops of ANY Conditions : 0
Hg MacUnderflow       : 0
TX Err PKT Counter    : 0

```

```
--- Error counters---  
Internal Mac Transmit Errors : 0  
Unknown Opcodes             : 0  
Internal Mac Receive Errors  : 0  
Dell(conf)#
```



# Internet Control Message Protocol (ICMP) Message Types

This chapter lists and describes the possible ICMP message type resulting from a ping. The first three columns list the possible symbol or type/code. For example, you would receive a ! or 03 as an echo reply from your ping.

**Table 5. ICMP messages and their definitions**

Symbol	Type	Code	Description	Query	Error
.			Timeout (no reply)		
!	0	3	echo reply	.	
U	3		destination unreachable:		
		0	network unreachable		.
		1	host unreachable		.
		2	protocol unreachable		.
		3	port unreachable		.
		4	fragmentation needed but don't fragment bit set		.
		5	source route failed		.
		6	destination network unknown		.
		7	destination host unknown		.
		8	source host isolated (obsolete)		.
		9	destination network administratively prohibited		.
		10	destination host administratively prohibited		.
		11	network unreachable for TOS		.
		12	host unreachable for TOS		.
		13	communication administratively prohibited by filtering		.
		14	host precedence violation		.
		15	precedence cutoff in effect		.
C	4	0	source quench		.
	5		redirect		.
		0	redirect for network		.
		1	redirect for host		.
		2	redirect for type-of-service and network		.
		3	redirect for type-of-service and host		.
	8	0	echo request	.	
	9	0	router advertisement	.	

**Table 5. ICMP messages and their definitions (continued)**

Symbol	Type	Code	Description	Query	Error
	10	0	router solicitation	.	
&	11		time exceeded:		
		0	time-to-live equals 0 during transit		.
		1	time-to-live equals 0 during reassembly		.
	12		parameter problem:		
		1	IP header bad (catchall error)		.
		2	required option missing		.
	13	0	timestamp request	.	
	14	0	timestamp reply	.	
	15	0	information request (obsolete)	.	
	16	0	information reply (obsolete)	.	
	17	0	address mask request	.	
	18	0	address mask reply	.	